

Printed Help Document



TDSDVI

DVI Compliance Test Solution Software

PHP0231

Adapted from the TDSDVI Online Help

This document supports software
version 1.3.0 and above
www.tektronix.com

Copyright Notice

Copyright © Tektronix 2005, Inc. All rights reserved. Licensed software products are owned by Tektronix or its suppliers and are protected by United States copyright laws and international treaty provisions.

Use, duplication or disclosure by the Government is subject to restrictions as set forth in subparagraph (c)(1)(ii) of the Rights in Technical Data and Computer Software clause at DFARS 252.227-7013, or subparagraphs (c)(1) and (2) of the Commercial Computer Software-Restricted Rights clause at FAR 52.227-19, as applicable.

Tektronix products are covered by U.S. and foreign patents, issued and pending. Information in this documentation supercedes that in all previously published material. Specifications and price change privileges reserved.

Tektronix, Inc. P.O. Box 500, Beaverton, OR 97077

Tektronix, Tek, and TEKPROBE are registered trademarks of Tektronix, Inc.

TDSDVI Compliance Test Solution User Manual PHP231 version 1.3.0

Table Of Contents

General Safety Summary.....	vii
To avoid Fire and Personal Injury	vii
Terms in this Manual	vii
Introduction	1
About TSDSDVI Application.....	1
Online Help and Related Documentation	2
Conventions	2
Contact Tektronix	3
Feedback	3
Using Online Help	4
Printing from the Online Help	5
Getting Started.....	7
Compatibility	7
Requirements and Restrictions	7
Accessories	8
Updates from the web site	8
Installing and Uninstalling the Application.....	9
Installing the Application.....	9
Uninstalling the Application.....	9
Basic Application Functions.....	9
Starting the Application	9
Minimizing and Maximizing the Application Window	10
Returning to the Application.....	11
Exiting the Application	11
Application Directories and File Names.....	11
File Name Extensions	12
Operating Basics.....	13
TSDSDVI Application Window	13
Application Interface Controls.....	13
Measurement Selection Pane	13
Cable Tab.....	14
Receiver Tab	15
Device Selection Tab	16
Define Tbit Selection Area	16
Control Panel	17
Status Bar	18
Menus	18
Menu Bar	18
File Menu.....	18
Measurements Menu.....	19
Results Menu	19
Utilities Menu	20

Help Menu	20
Dialog Boxes	20
Dialog Boxes, Panels and Windows	20
Preferences	21
Recall Default	23
Calculator Keypad	24
Virtual Keyboard	25
Exit	25
Result Detail	27
Report Generator	28
Eye Zoom	31
Compare Results	32
Eye Trends in TDS6604, TDS6404, TDS6604B, and TDS6804B Oscilloscopes	36
Transmitter, Cable, Receiver Screen Interface	40
About Transmitter, Cable, and Receiver	40
Transmitter Eye Diagram Screen Interface	40
Transmitter Eye Diagram Pane	40
Select Source	41
Select Pair	41
Number of Eyes	42
Calculate Vswing	43
Transmitter Rise and Fall Time Screen Interface	43
Transmitter Rise and Fall Time Pane	43
Select Source	45
Select Pair	45
Hysteresis	46
Calculate Vswing	46
Transmitter Pk-Pk Jitter Screen Interface	47
Transmitter Pk-Pk Jitter Pane	47
Select Source	48
Transmitter Intra-Pair Skew Screen Interface	48
Transmitter Intra-Pair Skew Pane	48
Select Source	49
Select Pair	50
Hysteresis	50
Transmitter Inter- Pair Skew Screen Interface	50
Transmitter Inter-Pair Skew Pane	50
Select Source	52
Select Pair	52
Hysteresis	53
Cable High-Amplitude/Low Amplitude Eye Diagram Screen Interface	53
Cable High-Amplitude Eye Diagram Pane	53
Cable Low-Amplitude Eye Diagram Pane	54
Select Source	56
Select Pair	56
Number of Eyes	57

Cable Pk-Pk Jitter Screen Interface	57
Cable Pk-Pk Jitter Setup Pane	57
Select Source.....	58
Cable Intra-Pair Skew Screen Interface.....	59
Cable Intra-Pair Skew Setup Pane	59
Select Source.....	60
Select Pair	60
Hysteresis.....	61
Cable Inter-Pair Skew Screen Interface.....	61
Cable Inter-Pair Skew Setup Pane	61
Select Source.....	62
Select Pair	63
Hysteresis.....	63
Receiver High-Amplitude/Low Amplitude Eye Diagram Screen Interface.....	63
Receiver High-Amplitude Eye Diagram Pane	64
Receiver Low-Amplitude Eye Diagram Pane	65
Select Source.....	66
Select Pair	66
Number of Eyes	67
How to Calculate Tbit.....	67
Enter a User Defined Tbit Value	69
Troubleshooting Tbit Calculation Error Messages.....	69
How to Test Transmitter For Eye Diagram	70
Selecting and Configuring Measurement: Eye Diagram	70
Viewing Results: Eye Diagram.....	74
Generating Reports	75
How to Test Transmitter for Rise Time and Fall Time	78
Selecting and Configuring Measurements: Rise and Fall Time	78
Viewing Results: Rise and Fall Time	80
Generating Reports	82
How to Test Transmitter for Pk-Pk Jitter	84
Selecting and Configuring Measurements:Pk-Pk Jitter	84
Viewing Results: Pk-Pk Jitter.....	87
Generating Reports	88
How to Test Transmitter for Intra-Pair Skew.....	90
Selecting and Configuring Measurements: Intra-Pair Skew.....	90
Viewing Results: Intra-Pair Skew.....	92
Generating Reports	93
How to Test Transmitter for Inter-Pair Skew	95
Selecting and Configuring Measurements: Inter Pair Skew	95
Viewing Results: Inter-Pair Skew.....	96
Generating Reports	98
How to Test Cable for Hi-Amplitude/Low-Amplitude Eye Measurement	99
Select and Configure Measurements:High-Amplitude/Low-Amplitude Eye Diagram	99
Viewing Results: High-Amplitude/Low-Amplitude Eye Diagram	104
Generating Reports	106

How to Test Cable for Pk-Pk Jitter.....	107
Selecting and Configuring Measurements:Pk-Pk Jitter	107
Viewing Results-Pk-Pk Jitter.....	110
Generating Reports	111
How to Test Cable for Intra-Pair Skew	113
Selecting and Configuring Measurements: Intra-Pair Skew	113
Viewing Results: Intra-Pair Skew	115
Generating Reports	117
How to Test Cable for Inter-Pair Skew	118
Selecting and Configuring Measurements: Inter-Pair Skew	118
Viewing Results-Inter-Pair Skew	120
Generating Reports	121
How to Test Receiver For High-Amplitude/Low-Amplitude Eye Diagram	122
Selecting and Configuring Measurements: High-Amplitude/ Low-Amplitude Eye Diagram	122
Viewing Results: High-Amplitude/Low-Amplitude Eye Diagram	125
Generating Reports	127
Save and Recall Setups.....	128
Recall Default Setup	129
Save a Setup.....	129
Recall a Setup	129
Recall a Recently Recalled Setup	130
Recall a Recently Saved Setup	130
Application Examples	131
About Application Examples	131
Tbit	131
Specifying the Equipment: Define Tbit.....	131
Equipment Setup: Define Tbit.....	131
Transmitter-Eye Diagram.....	133
Specifying the Equipment: Transmitter Eye Diagram.....	133
Equipment Setup-Transmitter: Eye Diagram	134
Transmitter-Rise and Fall Time.....	136
Specifying the Equipment: Transmitter Rise and Fall Time	136
Equipment Setup: Transmitter- Rise and Fall Time	137
Transmitter-Pk-Pk Jitter	139
Specifying the Equipment: Transmitter PK-Pk Jitter	139
Equipment Setup: Transmitter-Pk-Pk Jitter.....	140
Transmitter- Intra-Pair Skew.....	142
Specifying the Equipment: Transmitter-Intra-Pair Skew	142
Equipment Setup: Transmitter-Intra-Pair Skew	143
Transmitter- Inter-Pair Skew.....	145
Specifying the Equipment: Transmitter-Inter-Pair Skew	145
Equipment Setup: Transmitter-Inter-Pair Skew	146
Cable-Pk-Pk Jitter.....	148
Specifying the Equipment: Cable-Pk-Pk Jitter	148
Equipment Setup: Cable Pk-Pk Jitter	149
Cable-Intra-Pair Skew	150

Specifying the Equipment: Cable Intra-Pair Skew	150
Equipment Setup: Cable Intra-Pair Skew Tbit	150
Cable Inter-Pair Skew	152
Specifying the Equipment: Cable Inter-Pair Skew	152
Equipment Setup: Cable Inter-Pair Skew	153
Cable-Hi-Amplitude/Low-Amplitude Eye Diagram	154
Specifying the Equipment: Cable High-Amplitude/Low-Amplitude Eye Diagram	154
Equipment Setup: Cable-High-Amplitude/Low-Amplitude Eye Diagram ...	155
Receiver-Hi-Amplitude/Low-Amplitude Eye Diagram	160
Specifying the Equipment: Receiver High-Amplitude/ Low-Amplitude Eye Diagram	160
Equipment Setup Receiver: High-Amplitude/Low-Amplitude Eye Diagram	160
Measurement Algorithms	163
Eye	163
Eye Openings.....	164
Inter-Pair Skew	166
Intra-Pair Skew	167
Pk-Pk Jitter.....	168
Rise and Fall Time.....	168
Generation of Cable High Amplitude Eye Mask.....	169
Generation of Cable Limit Eye Mask.....	170
Generation of Cable Low Amplitude Eye Mask	170
Generation of Receiver High Amplitude Eye Mask.....	171
Generation of Receiver Low Amplitude Eye Mask	171
Generation of Transmitter Eye Mask	172
Reference.....	173
Equivalent Source Board	173
Shortcut Keys.....	175
Default Settings	176
Error Codes.....	177
Error Codes Contd.....	178
Standard Resolutions	180
Resolutions On TDS/CSA7404/7404B, TDS7704B and TDS6604, TDS6404, TDS6604B, and TDS6804B Oscilloscopes.....	181
Resolutions On TDS7254/TDS7254B Oscilloscopes	181
How do you generate Patterns (in infinite loops) to Conduct a Test?	182
Set Cursors for Eye, RT & FT Testing.....	182
Cable Setup at TP2	184
How do you increase or decrease the Vswing?	184
Cable Setup at TP3	185
TPA-P Test Points	185
TPA-R Test Points.....	187
Glossary.....	189

General Safety Summary

Review the following safety precautions to avoid injury and prevent damage to the measurement instrument or any products connected to it. To avoid potential hazards, use the software and measurement instrument only as specified.

While using this software, you may need to access other parts of the system. Read the General Safety Summary and specification sections in other equipment manuals for warnings, cautions, and ratings related to operating the system with this software.

To avoid Fire and Personal Injury

Connect and Disconnect Properly. Connect the probe output to the measurement instrument before connecting the probe to the circuit under test. Disconnect the probe input and the probe ground from the circuit under test before disconnecting the probe from the measurement instrument.

Observe All Terminal Ratings. To avoid fire or shock hazard, observe all ratings and markings on the measurement instrument and other equipment used with this software. Consult the individual product manuals for further ratings information before making connections to the circuit under test.

Do Not Operate With Suspected Failures. If you suspect there is damage to the measurement instrument or other equipment being used with this software, have it inspected by qualified service personnel.

Terms in this Manual

These terms may appear in this manual

WARNING. Warning statements identify conditions or practices that could result in injury or loss of life.

CAUTION. Caution statements identify conditions or practices that could result in damage to the measurement instrument or other property.

Introduction

About TSDSDVI Application

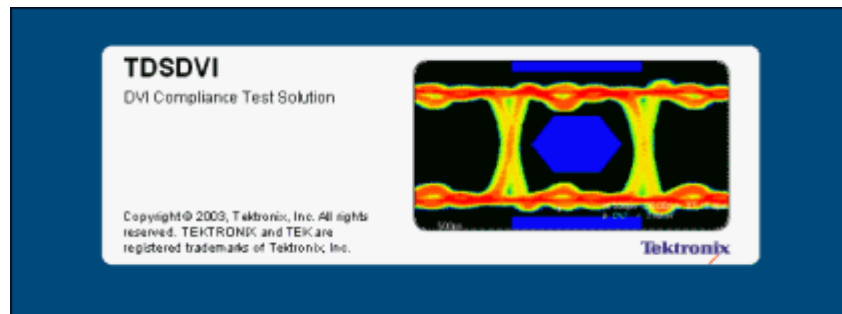

Figure 1-1

The TSDSDVI is a Digital Visual Interface Compliance Test Solution that helps test, validation and design engineers perform DVI physical layer validation and compliance testing. TSDSDVI Test Solution is the first test solution to provide credible test results in conformance with the DVI specifications and the DVI Test and Measurement Guide.

TSDSDVI provides fully automatic testing by providing automatic oscilloscope set-ups, eye mask generation and parametric testing for DVI compliance.

The TSDSDVI complies with the DVI specifications and:

- Enables the DVI developers to test designs according to the test procedures in the DVI Test and Measurement Guide.
- Offers automated tests for:
 - Transmitter: Eye Diagram, Pk-Pk Jitter, Intra-Pair Skew, Inter-Pair Skew, Rise and Fall Time
 - Cable: High-Amplitude Eye Diagram, Low-Amplitude Eye Diagram, Pk-Pk Jitter, Intra-Pair Skew, Inter-Pair Skew
 - Receiver: High-Amplitude Eye Diagram, Low-Amplitude Eye Diagram
- Automatic "one-button" testing ensures faster validation with higher reliability.
- Supports all resolutions till UXGA.
- Half Clock and Pseudo Random Patterns for various resolutions allow testing as per DDWG procedures.

Online Help and Related Documentation

You can access the information on how to operate the application, along with the oscilloscope, through the following related documents and online help.

- Oscilloscope Information: The user manual and user online help for your oscilloscope provides general information on how to operate the oscilloscope.
- You can download PDF versions of many user manuals from the Tektronix Website.
- Programmer Information: The online programmer guide for your oscilloscope provides details on how to use GPIB commands to control the oscilloscope.

You can download programmer information and examples from the Tektronix Website.

Refer to the *Optional Applications Software on Windows-Based Oscilloscopes Installation Manual* for the following information:

- Software warranty
- Software license agreement
- List of all available applications, compatible oscilloscopes, and relevant software and firmware version numbers
- How to apply a new label
- Installation procedures
- How to enable an application
- How to download updates from the Tektronix Website

You can find a PDF (portable document format) file for this document in the Documents directory on the *Optional Applications Software on Windows-Based Oscilloscopes* CD-ROM. The CD booklet only contains information on installing the application from the CD and on how to apply a new label.

Conventions

This online help uses the following conventions:

- Refers to the TDS DVI Compliance Test Solution as the TDS DVI or as the application or the software.
- ESB refers to the Equivalent Source Board, HCP to Half Clock Pattern and PRP to Pseudo Random Pattern.
- When steps require a sequence of selections using the application interface, the ">" symbol marks each transition between a menu and an option. For example, **File > Minimize**.
- GP knob refers to the General Purpose Knob.

- DUT refers to the device under test. This can be a Transmitter, Cable or a Receiver device.
- CRU is the Clock Recovery Unit.
- In the application fields, you can use either the calculator keypad or the GP knob to enter the values.
- PLL Clk or PLL Clock refers to the Phase Locked Loop Clock.

Contact Tektronix

Phone	1-800-833-9200*
	Tektronix, Inc.
	Department or name (if known)
Address	14200 SW Karl Braun Drive
	P.O. Box 500
	Beaverton, OR 97077
	USA
Website	www.tektronix.com
Sales support	1-800-833-9200, select option 1*
Service Support	1-800-833-9200, select option 2*
	Email: techsupport@tektronix.com
Technical Support	1-800-833-9200, select option 3*
	6:00 a.m. - 5:00 p.m. Pacific time

*** This Telephone number is toll free in North America. After office hours, please leave a voice mail message. Outside North America, contact a Tektronix sales office or distributor; See the Tektronix web site for a list of offices.**

Feedback Tektronix values your feedback on our products. To help us serve you better, please send us your suggestions, ideas or comments on your oscilloscope. Direct your feedback via email to

dvifedback@tek.com

and include the following information. Please be as specific as possible.

General information:

- Oscilloscope model number and hardware options, if any.
- Probes used.
- Your name, company, mailing address, phone number, FAX number.
- Please indicate if you would like to be contacted by Tektronix about your suggestion or comments.

Application specific information:

- Software version number.
- Firmware version of the oscilloscope.
- Description of the problem such that technical support can duplicate the problem.
- If possible, save the oscilloscope and application setup files as .set or .ini files.
- If possible, save the waveform on which you are performing the measurement as a .wfm file.

Once you have gathered this information, you can contact technical support by phone or through e-mail. If using e-mail, be sure to enter in the subject line "TDS DVI Problem," and attach the .set, .ini and .wfm files.

Using Online Help Select Help on the right side of the application menu bar to bring up the online help.

Tables of Contents (TOC) tab — organizes the Help into book-like sections. Select a book icon to open a section; select any of the topics listed under the book.

Index tab — enables you to scroll through alphabetical list of keywords. Select the topic of interest to bring up the appropriate help page.

Search tab — allows a text-based search. Follow these steps:

- Type the word or phrase you want to find in the search box.
- Select some matching words in the next box to narrow your search.
- Choose a topic in the lower box, and then select the Display button.
- To print a topic, select the Print button from the Help Topics menu bar.
- Select Options from the menu bar for other commands, such as annotating a topic, keep the help window on top, or to use system colors.
- Select the Back button to return to the previous help window. Use the hyperlink to jump from one topic to another. If the Back button is grayed out or a jump is not available, choose the Help Topics button to return to the originating help folder.
- Browse buttons (Next >> and Previous <<) allow you to move forward and backward through topics in the order of the Table of Contents (TOC).

Sometimes you will see the word **Note** in the topic text. This indicates important information.

***Note:** Certain aspects of the online help are unique to application that run on the oscilloscope.*

Blue-underlined text indicates a jump (hyperlink) to another topic. Select the blue text to jump to the related topic. For example, select the blue text to jump to the topic on Online Help and Related Documentation and the Back button to return to the previous page.

You can tell when the cursor is over an active hyperlink (button, jump, or pop-up), because the cursor arrow changes to a small hand.

Printing from the Online Help

You can access the information on how to operate the application, along with the oscilloscope, through the following related documents and online help.

While using the TDSDVI online help, you can print topics and information from the Help viewer. Some online help topics have color in the examples of the displayed application. If you want to print this type of topic on a monochrome printer, some information may not print because of certain colors. Instead, you should print the topic from the PDF (portable document format) file that corresponds to the Online Help. You can find the file in the Documents directory on the *Optional applications Software on Windows-Based Oscilloscopes* CD-ROM. The figures of application menus in the PDF file are gray scale so the relevant information will appear on the printed page.

To print a single topic:

1. Find the topic in the Contents pane.
2. Click **Print**.
3. Click **Print** the selected topic and click **OK**.

To print all topics in a selected TOC book:

1. Find the TOC book in the Contents pane.
2. Click **Print**.
3. Click **Print the selected heading and all subtopics** and click **OK**.

Getting Started

Compatibility

The TSDSDVI application is compatible with the following oscilloscopes:

- CSA7404, CSA7404B, TDS7404, TDS7404B, TDS7254, TDS7524B, TDS7704B (supports DVI resolutions up to SVGA), TDS6604, TDS6404, TDS6604B, and TDS6804B oscilloscopes
- TDS6124C and TDS6154C oscilloscopes

Requirements and Restrictions

Do not change the oscilloscope settings when a test is running. If you change the settings, the application may give incorrect test results.

Prerequisites

- Please read the Readme.txt file before you install the application.
- TekVisa must be installed on the oscilloscope. If you do not have TekVisa, you can download it from www.tektronix.com.
- The Sun Java Run-Time Environment V1.3.1 must be installed on the oscilloscope to operate the application. If Java Run-Time Environment is not installed, it will be automatically installed when you install the application. If you remove JRE v1.3, you can reinstall it by reinstalling the application.
- Only CSA7404, CSA7404B, TDS7404, TDS7404B, TDS7254, TDS7524B, TDS7704B, TDS6604, TDS6404, TDS6604B, and TDS6804B oscilloscopes
- TDS6124C and TDS6154C oscilloscopes
- If the signal is not connected and the noise level is below 50 mV, the application detects and displays a message as "Improper Waveform".
- To get appropriate results in Pk-Pk Jitter measurements, from the oscilloscope menu bar, select Measure>Waveform Histograms>Adjust Histogram Box Limits.

For better and reliable results

To calibrate an oscilloscope, select Utilities > Instrument Calibration in the oscilloscope menu bar and select the Calibrate button.

- Oscilloscope should be calibrated (Signal Path Compensation). To calibrate an oscilloscope, select Utilities > Instrument Calibration in the oscilloscope menu bar and select the Calibrate button.

Accessories

The application supports the following differential probes:

- P7350
- P7330
- P6330

The application supports the following single-ended probes for skew testing:

- P7240
- P6249

Other accessories

- SMA Cable to connect recovered (PLL) clock from the TPA-R and TPA-P fixture
- TCA-BNC adapter to use a P6330 probe
- TCA-SMA adapter to use the SMA cables

Updates from the web site

You can find information about this and other applications at the Tektronix web site, www.tektronix.com. Check this site for application updates and other free applications.

To install an application update, you will need to download it from the Tektronix web site to the oscilloscope hard disk.

Note: *More information about changes to the application or installation is in a Readme.txt file on the web site. You should read it before you continue.*

Installing and Uninstalling the Application

Installing the Application Refer to the *Optional Applications Software on Windows-Based Oscilloscopes Installation Manual* for the following information:

- Installation procedures
- How to apply a new label
- How to enable an application
- How to download updates from the Tektronix web site

You can find a PDF (portable document format) file for this document in the Documents directory on the *Optional Applications Software on Windows-Based Oscilloscopes* CD-ROM. The CD booklet contains information on how to install the application from the CD and on how to apply a new label.

Uninstalling the Application To uninstall the application:

1. On the Windows task bar, Select **Start> Settings**.
2. Select **Control Panel> Add/Remove Programs**.
3. Select DVI Compliance Test Solution from the programs list. Select **Add/Remove** and the Installshield will take you through the uninstallation procedures.

Basic Application Functions

Starting the Application To start the TDS DVI application,

1. From the oscilloscope menu, select **File> Run Application> DVI Compliance Test Solution** to run the application.

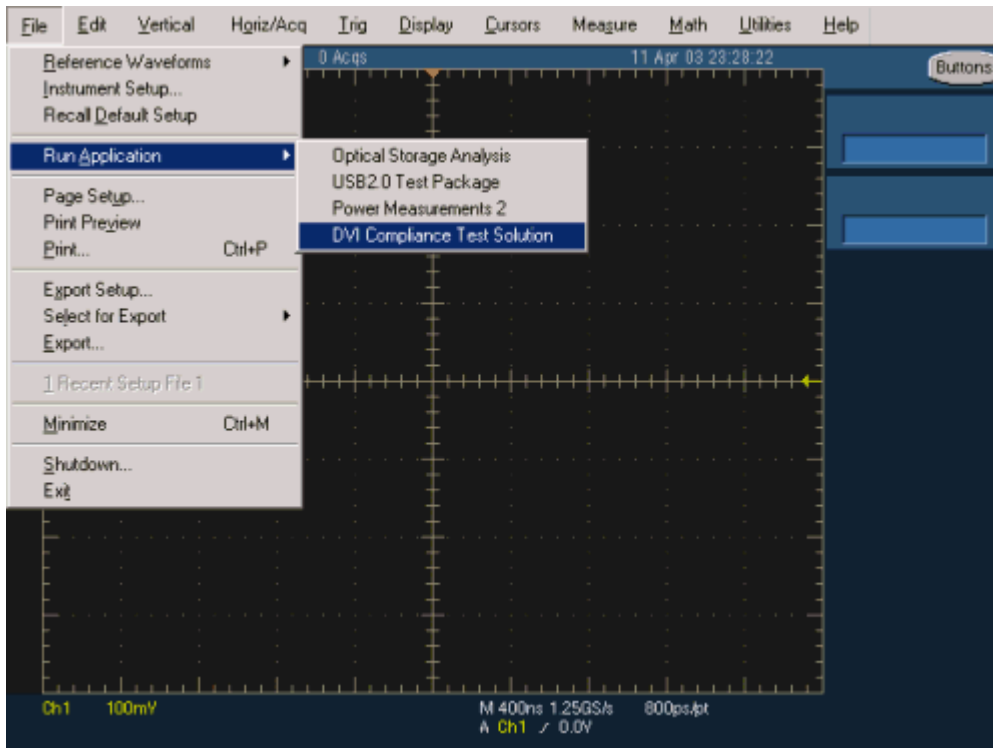
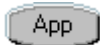



Figure 2-1: Starting the application

2. The oscilloscope display resizes to fit the upper half of the screen and the lower half of the oscilloscope screen displays the TDS DVI application user interface. If you access the oscilloscope functions, the oscilloscope display appears in full screen and the TDS DVI application interface recedes.
3. To return to the TDS DVI application interface, select the **App** button



Minimizing and Maximizing the Application Window

The application appears even when you minimize the oscilloscope display.

1. To minimize the application, select **File> Minimize**.
2. To maximize the application, select TDS DVI application in the Windows toolbar.
3. To hide the application, select the **Hide** button 

Note: If you select Hide button, the TDS DVI application window minimizes to the Windows taskbar and the oscilloscope display resizes to the full screen.

If you select File> Minimize, the application window minimizes to the Windows taskbar. The upper half of the screen shows the oscilloscope display and the lower half of the screen shows the Windows desktop.

Returning to the Application

When you access oscilloscope functions, the oscilloscope fills the display. You can access oscilloscope functions in the following ways:

- Choose the Menu bar or the Toolbar mode on the oscilloscope and access the menus.
- Press front-panel buttons.
- To return to the application, choose the App button  on the top right hand side of the oscilloscope.
- If you select **File> Minimize** to minimize the application, double-click on TDS DVI in the taskbar to bring back the application.

Exiting the Application

To exit the application:

- Select **File> Exit** or select  from the right-hand corner of the application.

Application Directories and File Names

The application uses specific directories to save and recall files. Table 2-1 lists the default directory names.

Table 2-1: Application directories

Directory	Function
C:\TekApplications\TDS DVI\Setup	Stores the application setup files
C:\TekApplications\TDS DVI\Reports	Stores the report generated
C:\TekApplications\TDS DVI\Images	Stores the zoomed eye images with the statistics
C:\TekApplications\TDS DVI\Patterns	Stores the Pseudo Random and the Half Clock Patterns

File Name Extensions The application uses these file name extensions to identify the file type. Table 2-2 lists the file name extensions.

Table 2-2: File name extensions

File name extensions	Description
.ini	Application setup file
.set	Oscilloscope setup file saved and recalled with a .ini file; both the files will have the same file name
.html	Report file or a compared result file
.bmp	Format of the HCPand PRP pattern files
.jpg	Eye mask image file
.gif	Tektronix logo image

Operating Basics

Application View

TDSdVI Application Window The TDSdVI application is a Windows-based application. The application window contains a Menu Bar, Device Selection Tab, Measurement Selection Pane and the Status Bar.

You can select Transmitter, Cable or Receiver from the Device Selection Tab. Select any of the device to display its measurement selection pane. For more information on a control, click one of the highlighted areas on the graphic below.

Application Interface Controls The application uses a Windows interface.

Note: The oscilloscope application shrinks to half size and appears in the top half of the display when the application is running.

Table 3-1 lists the application interface controls:

Table 3-1: Application interface controls

Control	Description
Menu bar	Located at the top of the application window and provide access to the application menus
Area/Tab	Enclosed visual frame with a set of related options
Option button	Selects a command or task
Drop-down List box	Lists items from which you can select one item
Field	Box that you can use to type in text or to enter a value with the keypad or a multipurpose knob
Check Boxes	Box that you use to select or clear preferences
Scroll bar	Vertical or horizontal bar at the side or bottom of a display area used to move around that area
Browse	Displays a window where you can look through a list of directories and files
Command button	Initiates an immediate action
Keypad	Used to enter numeric values
MP/GP knob	Displays a line between the knob and the box. You can turn the knob on the oscilloscope to select a value

Measurement Selection The measurement area, displayed in the center of the application window,

Pane displays the measurements you can select. These measurements vary depending on the selected tab.

Click on each of the tabs to see the different measurements and their parameters.

Transmitter Tab The application has three tabs: Transmitter, Cable and Receiver, based on the device to be tested as shown in Figure 3-1.

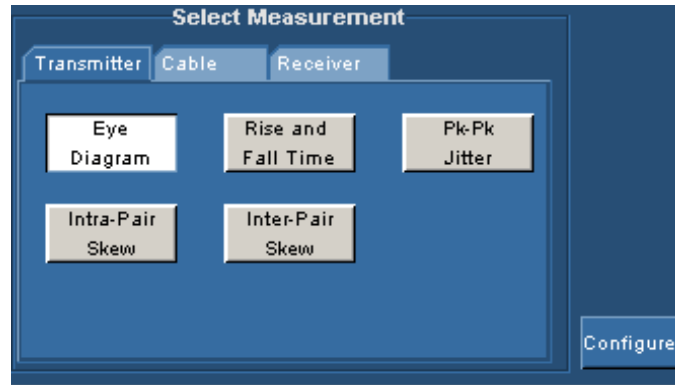

Figure 3-1: Transmitter Tab

Configuration parameters

If you select any measurement in the Transmitter Tab and click Configure, the configuration parameters for the selected measurement appears. Figure 3-2 shows the parameters you can configure for Transmitter

	Data	Trigger	Pair	Pair1	Pair2	Number of Eyes	Vswing	Tx Clock	Source1	Source2	Hysteresis
Eye Diagram	✓	✓	✓			✓	✓				
Rise and Fall Time	✓	✓	✓				✓				✓
Pk-Pk Jitter		✓						✓			
Intra-Pair Skew			✓						✓	✓	✓
Inter-Pair Skew				✓	✓				✓	✓	✓

Figure 3-2: Transmitter Measurements Matrix

Cable Tab The application has three tabs: Transmitter, Cable, and Receiver, based on the device to be tested as shown in Figure 3-3.

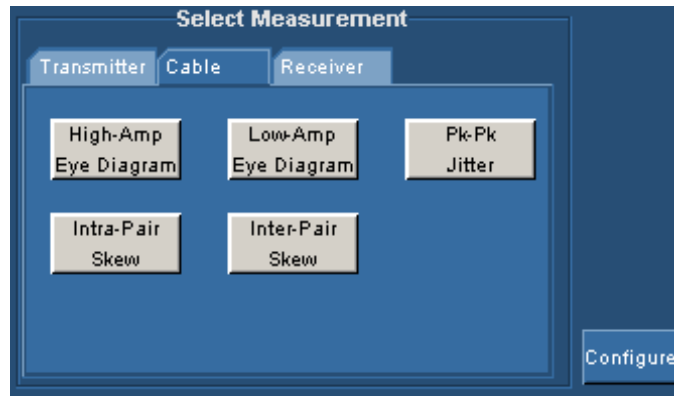

Figure 3-3: Cable Tab

Configuration parameters

If you select any measurement in the Cable Tab and click Configure, the configuration parameters for the selected measurement appears. Figure 3-4 shows the parameters you can configure for Cable.

	Data	Trigger	Pair	Pair1	Pair2	Number of Eyes	Vswing	Tx Clock	Source1	Source2	Hysteresis
Hi-Amp Eye Diagram	✓	✓	✓			✓					
Low-Amp Eye Diagram	✓	✓	✓			✓					
Pk-Pk Jitter		✓					✓				
Intra-Pair Skew			✓						✓	✓	✓
Inter-Pair Skew				✓	✓				✓	✓	✓

Figure 3-4: Cable measurements matrix

Receiver Tab The application has three tabs: Transmitter, Cable and Receiver, based on the device to be tested as shown in Figure 3-5.

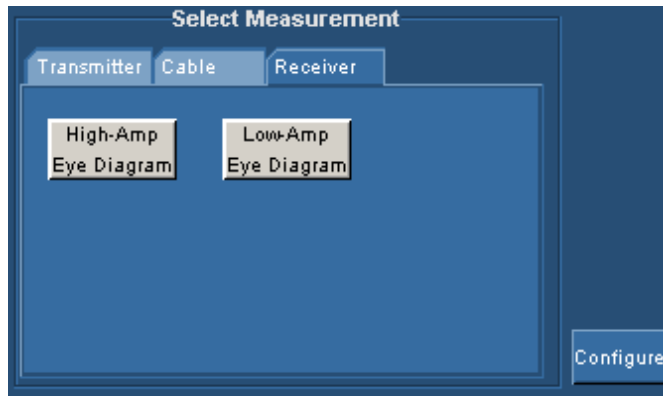

Figure 3-5: Receiver tab

Configuration parameters

If you select any measurement in the Receiver Tab and click **Configure**, the configuration parameters for the selected measurement appears. Figure 3-6 shows the parameters you can configure for Receiver.

	Data	Trigger	Pair	Pair1	Pair2	Number of Eyes	V _{swing}	Tx Clock	Source1	Source2	Hysteresis
High-Amplitude Eye Diagram	✓	✓	✓			✓					
Low-Amplitude Eye Diagram	✓	✓	✓			✓					

Figure 3-6: Receiver measurements matrix

Device Selection Tab

The device selection area is displayed above the measurement selection area of the application. You select the device based on your test as shown in Figure 3-7. Click on any of the tabs to display the measurements associated with it.

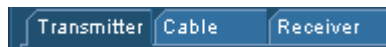

Figure 3-7: Transmitter, Cable and Receiver tabs

Define Tbit Selection Area

The Define Tbit Selection Area, displayed next to the Measurement Selection Area, helps you to define the Tbit parameters for all the measurements. You can select the **Calculated** option to assign a channel for the Tx Clock and calculate Tbit or select the **User** option to set a custom value. The application displays the calculated value in the **Tbit Value** field as shown in Figure 3-8.

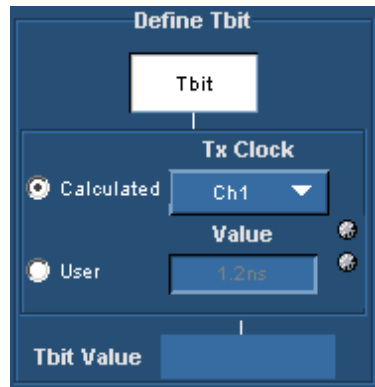



Figure 3-8: Define Tbit selection area

Control Panel The control panel on the right of the application displays the dual-purpose **Run/Stop** button. The **Run** is a toggle that changes to **Stop**  when you run any measurement. Table 3-2 lists the control panel options.

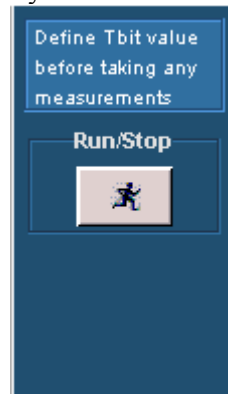



Figure 3-9: Control panel

Table 3-2: Control panel

Button	Button Name	Description
	Run/Stop	Executes the selected measurement or stops the application when the application is running.
		

Status Bar The status bar is displayed at the bottom of the application window. It displays the selected menu, related hint, and the status of the application.

Menus

Menu Bar The menu bar of the TDSDVI application provides access to the menus.

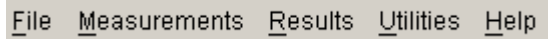

Figure 3-10: Application menus

File Menu

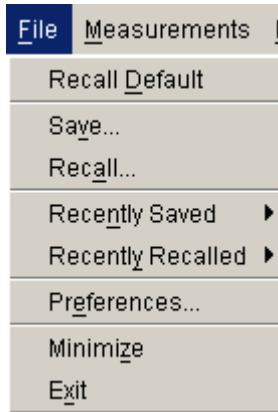

Figure 3-11: File menu

Table 3-3 lists the file menu items and their descriptions.

Table 3-3: File menu items and their descriptions

Menu Selection	Description
Recall Default	Recalls the default settings of the application.
Save	Saves the application settings to a .ini file and the oscilloscope settings in a .set file.
Recall	Recalls the previously saved settings of the application from a .ini file and the oscilloscope settings from a .set file.
Recently Saved	Displays the recently saved setup.
Recently Recalled	Displays the recently recalled setup.
Preferences	Displays user preferences in two tabs. In the General tab: <ul style="list-style-type: none"> ▪ Use Cursors for Eye, RT & FT Testing ▪ Prompt for signal connection ▪ Ref Wfm deletion prompt for Eye Diagram

	<p>Test</p> <ul style="list-style-type: none"> ▪ Show report after generation ▪ Use zoomed eye mask in report <p>In the Advanced tab:</p> <ul style="list-style-type: none"> ▪ Prompt for result reset ▪ Prompt for Tbit validity ▪ Select the test points for Cable Eye Diagram ▪ Specifies the number of acquisitions to create Eye Diagram in the Value field. This input is common for the General and Advanced tab
Minimize	Minimizes the application window
Exit	Exits the application window

Measurements Menu

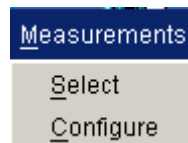

Figure 3-12: Measurements menu

Table 3-4 lists the measurement menu items and their descriptions.

Table 3-4: Measurement menu items and their descriptions

Menu Selection	Description
Select	Allows you to select the measurements to be performed.
Configure	Allows you to configure the parameters for the selected measurement.

Results Menu

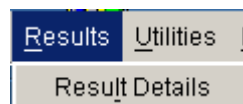

Figure 3-13: Results menu

Table 3-5 lists the result menu items and their descriptions.

Table 3-5: Results menu items and their descriptions

Menu Selection	Description
Result Details	Displays the detailed results of the selected measurement.

Utilities Menu



Figure 3-14: Utilities menu

Table 3-6 lists the utilities menu items and their descriptions.

Table 3-6: Utilities menu items and their descriptions

Menu Selection	Description
Report Generator	Displays the tabs— Report Setup and Report Name— to set the parameters for generating the reports.
Compare Results	Allows you to compare the current displayed result with a previous result from a file or two previous results from two files.

Help Menu



Figure 3-15: Help menu

Table 3-7 lists the help menu items and their descriptions.

Table 3-7: Help menu items and their descriptions

Menu Selection	Description
Topics	Displays the help for TDSVDI application.
About TDSVDI	Displays a dialog box with the version number and the copyright information about the current version of the application.
Contact Tektronix	Displays a dialog box with the contact email information.

Dialog Boxes

Dialog Boxes, Panels and For help on specific dialog boxes, panels and windows, display the Table of

Windows Contents for this help file, and then click the following book icons to display links to specific dialog boxes: **Operating Basics>Dialog Boxes, Panels and Windows.**

Preferences File> Preferences

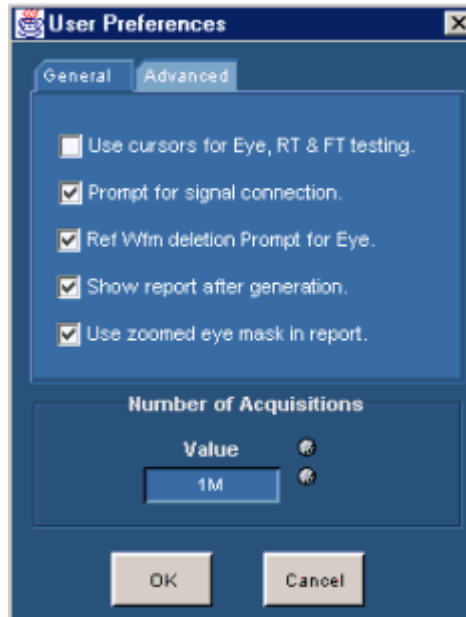

Figure 3-16: General tab

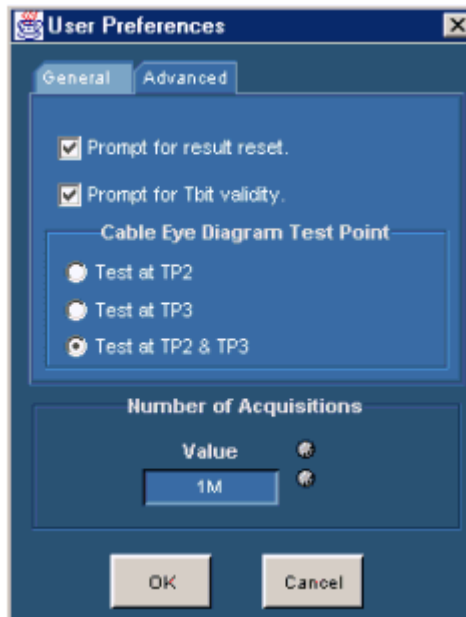

Figure 3-17: Advanced tab

Use this dialog box to set the user preferences in two tabs: **General** and **Advanced.**

In the **General** tab as shown in Figure 3-16, you can:

- Use cursors for Eye, RT & FT testing
- Prompt for signal connection
- Ref Wfm deletion prompt for Eye
- Show report after generation
- Use zoomed eye mask in report

In the **Advanced** tab as shown in Figure 3-17, you can:

- Prompt for result reset
- Prompt for Tbit validity
- Select Cable Eye Diagram Test Point

Number of Acquisitions field is common to the **General** and the **Advanced** tab.

Table 3-8 lists the options in the General and Advanced tab.

Table 3-8: Preferences options and their descriptions

Option	Action
Use Cursors for Eye, RT & FT testing	Automatically enables the oscilloscope cursors to calculate the Vswing and the worst eye opening. The application enables the horizontal cursors to find the Vswing value. To calculate the Vswing value: <ul style="list-style-type: none"> ▪ For the Eye Diagram and Rise and Fall Time measurements, place the cursors on the Vswing high and Vswing low of the eye diagram The application enables the vertical cursors to select the worst eye opening. To select the worst eye opening: <ul style="list-style-type: none"> ▪ Place the cursors at the crossover points of the worst eye opening for the Eye Diagram measurement. By default, the cursor option is not selected in the application.
Prompt for signal connection	Displays a message box prompting you to setup the connections and signal patterns when you run any measurement.
Ref Wfm deletion prompt for Eye	Displays a message box prompting you to save the Ref1 waveform with previous settings in another location because TDSDVI uses Ref1 for eye mask test and erases all the previous contents of Ref1. This happens when you run the Eye Diagram measurement.
Show report after generation	Automatically displays the report after the report is generated.

Use zoomed eye mask in report	In the generated report, the application uses the zoomed eye diagram with the mask. This is created using the Eye Zoom feature in Results> Result Detail> Eye zoom . If this checkbox is not selected, the application uses the oscilloscope screen shot of the eye diagram in the generated report.
Prompt for result reset	Displays a message box informing you that the previous results will be reset when you select the next measurement. This happens when you select successive measurements.
Prompt for Tbit validity	Displays a message box informing you to check the validity of Tbit calculation when you select any measurement and press the Run button.
Select Cable Eye Diagram test point	Specifies the different test points you can select like TP2, TP3 or TP2 and TP3 to measure Cable Eye Diagram. <i>Note: If you have a standard signal that passes low or high amplitude mask, advanced users do not have to test cable at TP2 with low or high amplitude mask every time they run the cable measurement. For this purpose, we recommend you to select the options in File> Preferences> Advanced> Cable Eye Diagram Test Point.</i>
Number of Acquisitions—Value	Specifies the number of acquisitions to create an Eye mask. You can use the calculator keypad  or the GP knob next to the value field, to enter the number of acquisitions. DVI Test and Measurement Guide recommends one million acquisitions to perform an Eye Diagram measurement. For the CSA/TDS7404/B, TDS7254/TDS7254B, and TDS7704B oscilloscopes, you can set a maximum of five million acquisitions and a minimum of five hundred thousand. For the TDS6604, TDS6604B, TDS6404, and TDS6804 oscilloscopes, you can set a maximum of one million and a minimum of ten thousand. <i>Note: Refer the topic Default Settings for more information.</i>

Recall Default File> Recall Default

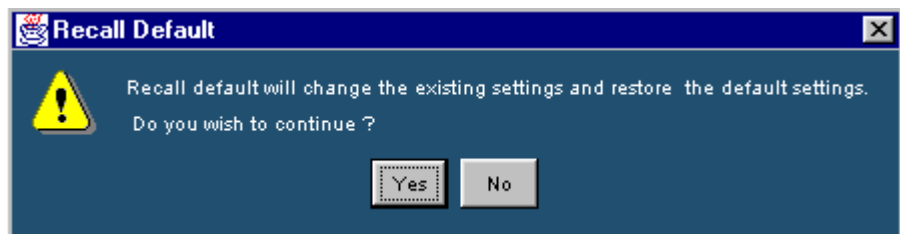

Figure 3-18: Recall Default message box

Use this dialog box to replace the existing settings with the default settings as shown in Figure 3-18. Select **Yes** to confirm the action and **No** to cancel the

action. If you select **Yes**, the application displays the next message box as shown in Figure 3-19.



Figure 3-19: Recall message box

If you select **No**, the Recall Default dialog box disappears, and the application does not recall the default settings.

Calculator Keypad **File> Preferences> Value Measurements> Select> Define Tbit> User> Value Measurements> Select> Transmitter-Eye Diagram> Configure>User Measurements> Select> Transmitter- Eye Diagram, Cable-High-Amplitude/Low-Amp Eye Diagram, Receiver-High-Amplitude/Low-Amp Eye Diagram> Configure> Number of Eyes**

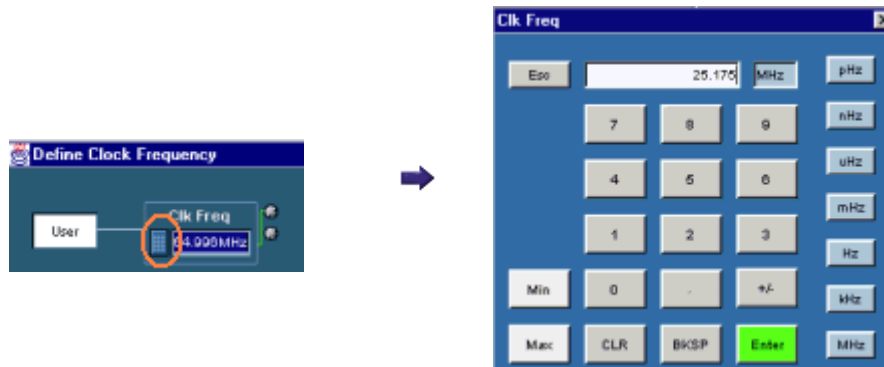

Figure 3-20: Calculator keypad

Table 3-9 lists the calculator keypad options and their descriptions.

Table 3-9: Calculator keypad keys and their descriptions

Button	Description
Min	Automatically displays the minimum value of the selected field
Max	Automatically displays the maximum value of the selected field
CLR	Clears the value for the field selected and returns to zero value
BKSP	Defines a backspace for the selected value
Enter	Enters the value for the selected field
Esc	Exits the calculator screen
pHz-MHz	Defines the frequency magnitude of the selected value

To enter the values,

1. Select the **Min** button to display the minimum value for the selected option.
2. Select the **Max** button to display the maximum value for the selected option.
3. Select the **CLR** button to erase the previous values.
4. Select the **numeric** buttons to define the numeric values.
5. Select the **Unit** buttons to define the unit of the selected value.
6. Select the **Enter** button to enter the numeric values.

**Virtual Keyboard Utilities> Report Generator> Report Setup> ID, Description, Prefix
 Utilities> Report Generator> Report Name> File Name
 Utilities> Compare Results> Select Files to Compare, Select Destination File**



Figure 3-21: virtual keyboard

Use this dialog box to enter:

- Device ID
- Prefix
- Description
- File Name

To enter values for the Device ID, Prefix, Description and File Name,

- Use the keyboard to enter the data in the fields. Select the **Enter** button to complete your entry as shown in Figure 3-21.

Exit File> Exit

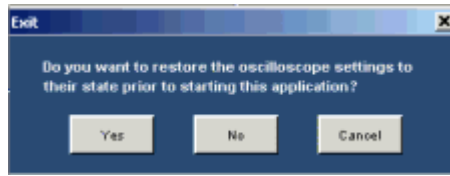

Figure 3-22: Exit dialog box

This dialog box appears when you exit the TDS DVI application. When you exit the application, you can:

- Restore the oscilloscope settings to their state prior to starting the application as shown in Figure 3-22
- Exit without changing the present oscilloscope settings as shown in Figure 3-22

Table 3-10 lists the exit dialog box options and their descriptions.

Table 3-10: Exit options and their descriptions

Option	Action
Yes	Restores the oscilloscope settings to their original state values prior to starting the application and exits.
No	Exits the application without changing the present oscilloscope settings.
Cancel	Cancels exiting the application.

Result Detail Results> Result Detail

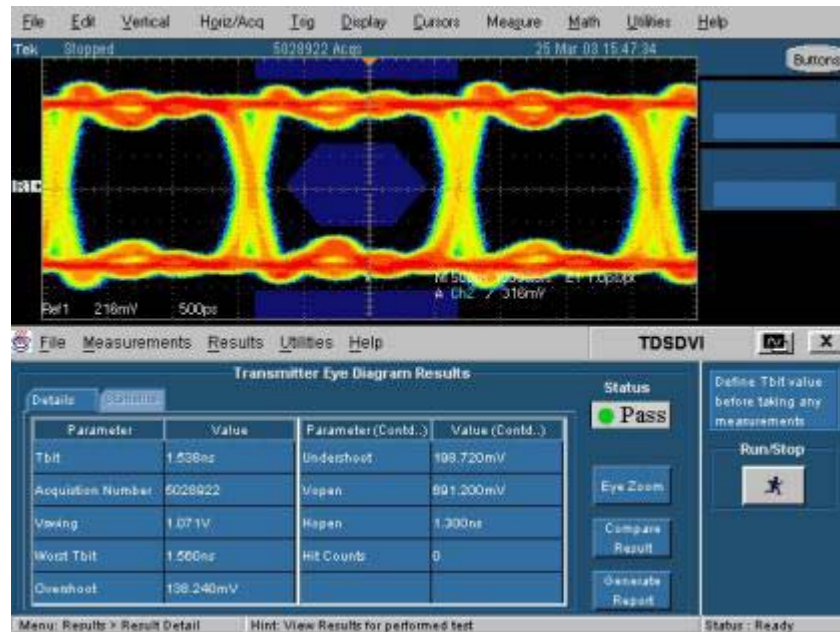

Figure 3-23: Result Details for Transmitter Eye Diagram

Use this dialog box to display the result **Details** and **Statistics** for the selected measurement as shown in Figure 3-23. The **Statistics** information is available only for the following measurements:

- Transmitter Rise and Fall Time
- Transmitter/Cable Intra-Pair Skew
- Transmitter/Cable Inter-Pair Skew

Table 3-11 lists the sample result details for Transmitter Eye Diagram their descriptions.

Table 3-11: Result details options and their descriptions

Option	Description
Details tab	
Status	The status of the measurement: Pass or Fail .
Parameter	The calculated parameters for the measurement.
Value	The result parameters with the values.
Compare Result	The option to compare results from two different results.
Eye Zoom	The option to view a zoomed eye mask only for Eye diagram measurement.

Generate Report | The option to generate a report.

Report Generator Utilities> Report Generator

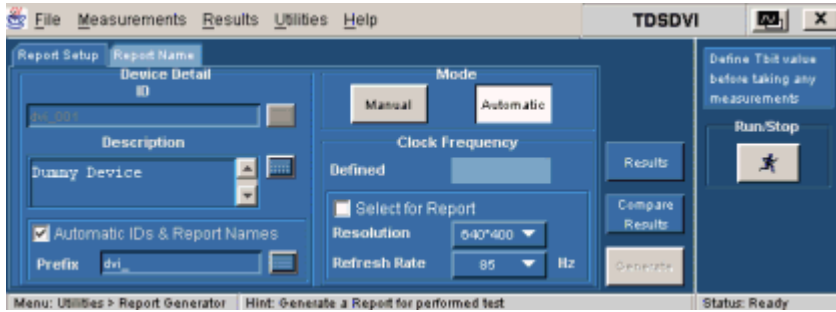

Figure 3-24: Report Setup tab

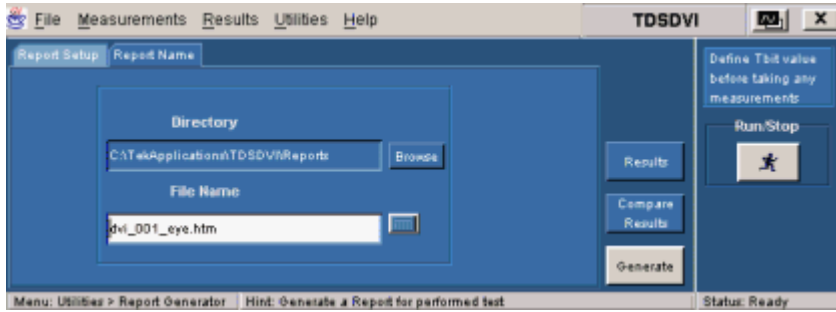

Figure 3-25: Report Name tab

Use this dialog box to specify— the **Report Setup** as shown in Figure 3-24 and the **Report Name** information and generate reports as shown in Figure 3-25.

Table 3-12 lists the report generator options their descriptions.

Table 3-12: Report generator options and their descriptions

Option	Description
Report Setup Tab	
ID	Specifies the device ID. You can use the virtual keyboard and enter the device ID or type the data in the field and press Enter.
Description	Specifies the test device description for which the report is to be generated. You can use the virtual keyboard next to the description field to enter the device description.
Automatic IDs and Report Names	Generates and specifies the device ID and the report names automatically, if the check box is selected. The ID field is disabled if you select this option. Select the check box before you run the measurement.
Prefix	Displays the specified prefix of the device. This field is enabled, only if you select the Automatic mode of report generation. You can use the virtual keyboard to enter the device prefix or key in the data in the field and press Enter.
Mode	Displays the Manual or the Automatic mode of report generation. If you select the Manual mode, the Prefix field is disabled and you have to enter the device ID and description. If you select the Automatic mode, the Device ID field is disabled and the Automatic ID's and Report Names check box is selected. The application then generates a report with its naming conventions without user intervention. You can also check or uncheck the Automatic Device ID's and Report Names for the Manual and the Automatic modes.
Defined	Specifies the clock frequency values automatically when you define and calculate Tbit.
Select for Report	Displays the selected resolution and refresh rate in the generated report.
Resolution Refresh Rate	Displays the Resolution and Refresh Rate values as per the VESA standard. Use the drop-down arrow in the Resolution and Refresh Rate fields to set the values. Refer the topic, Reference> Resolutions for more information on the available resolutions.
Generate	Generates an .html report for the selected measurement. If you select the Automatic mode, this button is disabled.
Report Name Tab	

Directory	Displays the directory location of the generated report.
Browse	Browses to the directory location.
File Name	Displays the file name of the report generated. Use the virtual keyboard to enter the file name or type the data in the field. If you select the Automatic mode, this field is disabled.
Generate	Generates an .html report for the selected measurement. If you select the Automatic mode, this button is disabled.

To generate a report:

1. Select **Utilities> Report Generator**.
2. In the **ID** field, use the virtual keypad to enter the device ID.
3. In the **Description** field, use the virtual keypad to enter the device description.
4. Select **Automatic IDs and Report Names** check box, if you want the application to generate a device ID and report names automatically.

***Note:** Select the **Automatic IDs and Report Names** check box before you run the measurement.*

5. In the **Prefix** field, use the virtual keypad to enter the device prefix.
6. Select the **Manual** mode to generate report manually and the Automatic mode if you want the application to generate the report automatically.
7. The **Defined field** automatically displays the predefined clock frequency values when you define and calculate Tbit.
8. Select the **Select for Report** checkbox, if you want the resolution and refresh rate values to generate the report.
9. Use the drop-down arrow in the **Resolution** and **Refresh Rate** field to set the values according to the VESA standard.
10. In the Report Name tab, select the **Browse** button to browse the directory location.
11. In the **File Name** field, use the virtual keypad to enter the file name. Select the Generate button display an .html report.

***Note:** From this screen, you can use the **Results** button to view the results and the **Compare Results** option to compare results of two different devices.*

Eye Zoom Results> Result Detail> Eye zoom

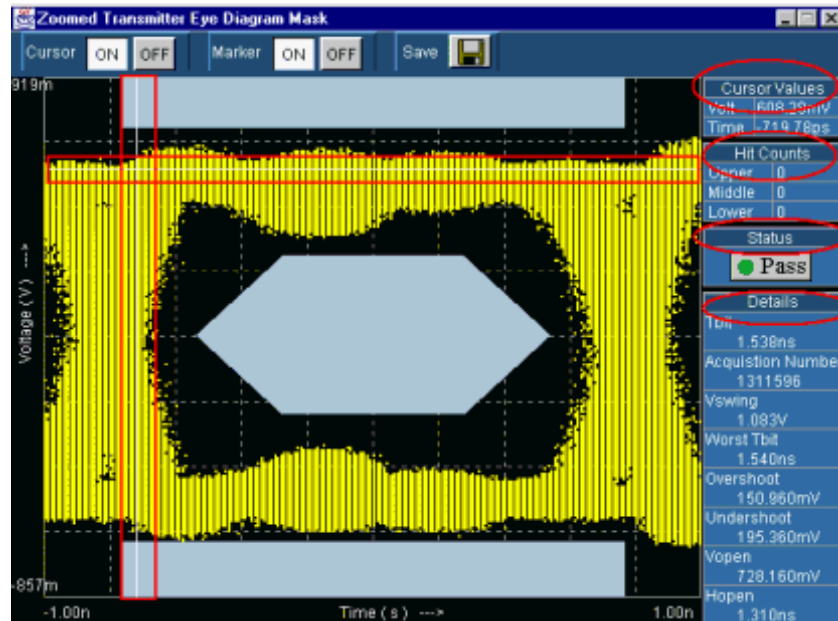

Figure 3-26: Zoomed eye

Use this dialog box shown in Figure 3-26 to:

- Display the zoomed worst eye opening with the mask
- Use the cross haired cursors to find specific failed points and display their respective voltage and time values
- Mark the failed data points in the eye mask to find specific failed points with markers. Markers are small red boxes that surround the failed points
- Identify the failed points in red and the pass points in yellow
- Save the eye mask for future reference to the default directory C:\TekApplications\TDS DVI\Images or any other directory of your choice
- Identify the Hit Counts, Test Status and Statistical information of the eye diagram

To enable the Cursor or the Marker option:

1. Select the **ON** button next to the cursor or marker option to enable cursors or markers. The X axis of the cursor represents Time and the Y axis represents Voltage. You can drag the cursor and position them anywhere on the eye mask.
2. Select the **OFF** button next to the cursor or the marker option to disable the cursors or the markers.

To save the zoomed eye mask:

- Select the **Save** button to save the mask in .jpg format to the default directory C:\TekApplications\TDSDVI\Images or any other directory of your choice. You cannot save the image when the measurement is running.

Table 3-13 lists the eye zoom options and their descriptions.

Table 3-13: Eye zoom options and their descriptions

Option	Description
Cursor Values	Displays the cursor positions with reference to Voltage in volts and Time in seconds.
Hit Counts	Displays the number of data points in the fail zone. With reference to the previous figure, they are: <ul style="list-style-type: none"> ▪ Upper: upper eye mask ▪ Middle: middle eye mask ▪ Lower: lower eye mask
Status	Displays the status of the test: Pass or Fail
Details	Displays the result details for the zoomed eye mask

Compare Results Results> Compare Results

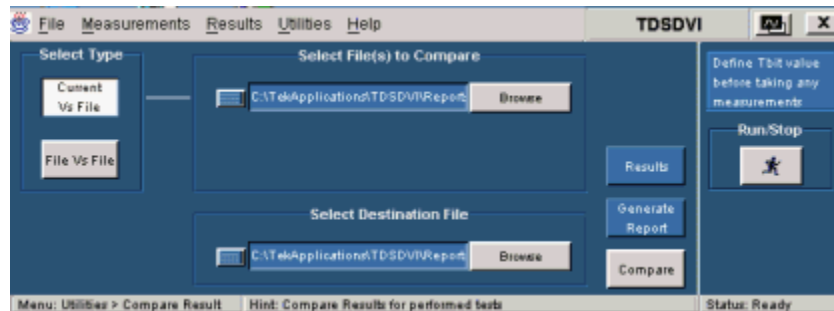

Figure 3-27: Compare results pane

Use this dialog box as shown in Figure 3-27 to compare either:

- The current results with results that are stored in a html file
- Results that are stored in two different html files

The **Current Vs File** option displays two fields where you can enter:

- The file name to be compared with the currently displayed results
- The file name in which the compared results will be stored

The **File Vs File** option displays three fields where you can enter:

- The names of the html files to be compared
- The name of the html file where the compared results will be stored

Figure 3-28 lists the result combinations you can compare:

	Transmitter Eye Diagram	Transmitter Rise and Fall Time	Transmitter Pk-Pk Jitter	Transmitter Intra-Pair Skew	Transmitter Inter-Pair Skew	Cable High/Low Amplitude Eye Diagram (with TP2)	Cable High/Low -Amplitude Eye Diagram (with TP3)	Cable High/Low-Amplitude Eye Diagram (with TP2 and TP3)	Cable Pk-Pk Jitter	Cable Intra-Pair Skew	Receiver High-Amplitude/Low Amplitude Eye Diagram	Cable Inter-Pair Skew
Transmitter Eye Diagram	✓					✓	✓				✓	
Transmitter Rise and Fall Time		✓										
Transmitter Pk-Pk Jitter			✓						✓			
Transmitter Intra-Pair Skew				✓						✓		
Transmitter Inter-Pair Skew					✓							✓
Cable High/Low - Amplitude Eye Diagram (with TP2)	✓					✓	✓				✓	
Cable High/Low - Amplitude Eye Diagram (with TP3)	✓					✓	✓				✓	
Cable High/Low-Amplitude Eye Diagram (with TP2 and TP3)								✓				
Cable Pk-Pk Jitter			✓						✓			
Cable Intra-Pair Skew				✓						✓		
Cable Inter-Pair Skew					✓							✓
Receiver High/Low-Amplitude Eye Diagram	✓					✓	✓				✓	

Figure 3-28: Result comparison matrix

To compare the current result with a stored result:

1. In the **Select File(s) to compare Result** field, select the **Current Vs File** option, and use the popup keyboard to enter the file name or use the browse button to browse for the file. You can also enter the file name directly in the field and press Enter.

2. In the **Select Destination File** field, use the popup keyboard to enter the compared result file name or use the browse button to browse the file.
3. Select the **Compare** button to complete the process.

To compare results stored in two different files:

1. In the **Select File(s) to compare Result** fields, select **File Vs File** option, and use the popup keyboard to enter the file names or use the browse button to browse the file. You can also enter the file name directly in the field and press Enter.
2. In the **Select Destination File** field, use the popup keyboard to enter the name of the destination where you want to store the compared results or use the browse button to browse the file. You can also enter the file name directly in the field and press Enter.
3. Select the **Compare** button to complete the process and display the compared report as shown in Figure 3-29.

Comparison Report of Transmitter Eye Diagram and Transmitter Eye Diagram

Parameter	Transmitter Eye Diagram	Transmitter Eye Diagram
Device ID	dvl_001	dvl_001
Device Description	Dummy Device	Dummy Device
Date	Mon Mar 31 14:09:43 GMT+05:30 2003	Mon Mar 31 14:11:22 GMT+05:30 2003
Status	Fail	Pass
Clock Frequency	44.504MHz	44.504MHz
Resolution	-	-
Refresh Rate	-	-
Number of Eyes Tested	2	2
Data Pair Used	RX0	RX0
Tbit	2.247ns	2.247ns
Acquisition Number	1290257	1300701
Vswing	654.000mV	602.800mV
Worst Tbit	4.000ns	2.251ns
Overshoot	8.720mV	35.200mV
Undershoot	322.640mV	30.800mV
Vopen	8.720mV	545.600mV
Hopen	1.540ns	2.190ns
Hit Counts	959	0

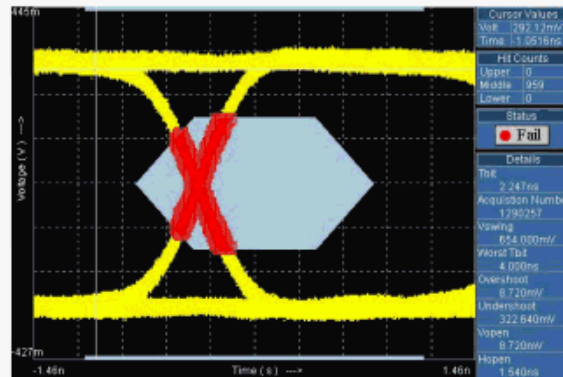

Eye Diagram

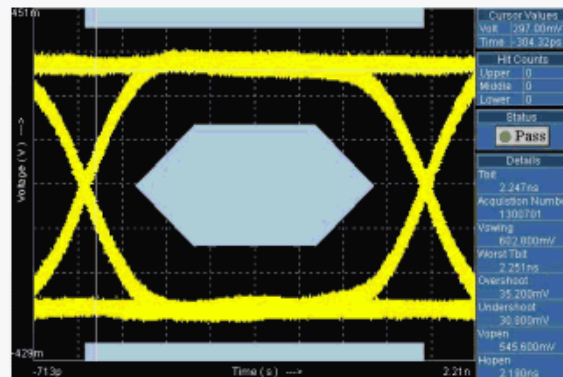

Eye Diagram



TDSOVI Version : 0.0.29

Figure 3-29: Compared results

Table 3-14 lists the compare result options and their descriptions.

Table 3-14: Compare results options and their descriptions

Option	Description
Current Vs File	Compares the current results with the results already stored in a file.
File Vs File	Compares the results stored in two different files.
Results	Displays the results panel for the selected measurement.
Generate Report	Displays the generate report panel for the selected measurement.
Compare	Compares the results based on the type selected.

Eye Trends in TDS6604, TDS6404, TDS6604B, and TDS6804B Oscilloscopes

Results> Result Detail> Eye Trend

Use this dialog box to:

- Display the eye progression as shown in Figure 3-30
- Display the Vertical and Horizontal trends of the eye diagram parameters such as Mask, Vswing, Overshoot, Undershoot, Tbit, Worst Tbit, Hopen and Vopen as shown in Figure 3-30

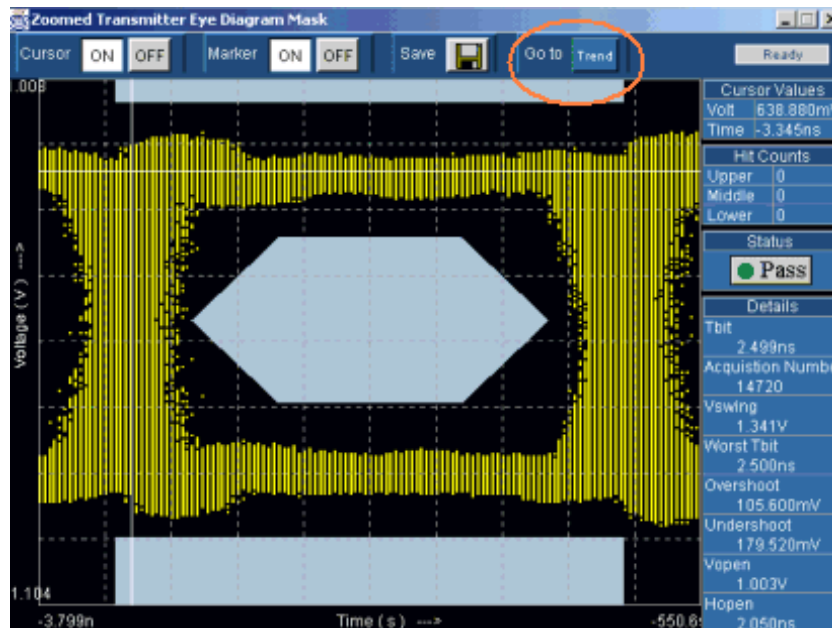

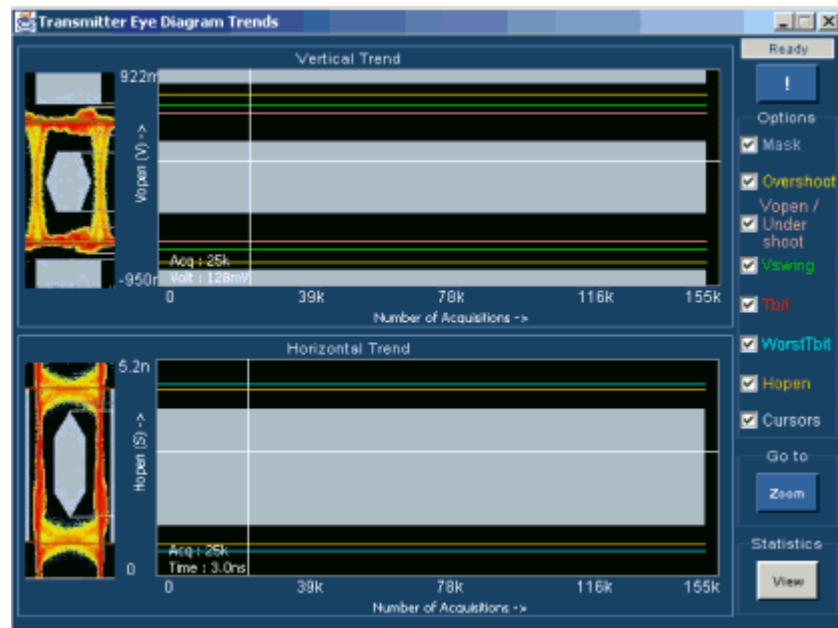

Figure 3-30: Eye trends in TDS6000 series oscilloscopes

To view the Eye Diagram Trends,

1. Select the **Eye Zoom** button to display the zoomed eye mask or press the **Eye Trend** button in the results panel.
2. Select the **Go to Trend** button to display the Vertical and Horizontal trends as shown in the next screen.

The TDS6604, TDS6404, TDS6604B, and TDS6804B oscilloscopes do not support FastAcq mode for gathering one million acquisitions, which is recommended for DVI compliance. The Eye-Trends feature on the TDS6604, TDS6404, TDS6604B, and TDS6804B oscilloscopes helps you to monitor eye formation and also look at the trends for important parameters, such as, Tbit, Hopen, Vopen, Worst Tbit, Overshoot and Undershoot. You can effectively test for DVI compliance by selecting a lower number of acquisitions. The Eye Trend begins with a minimum of 10K acquisitions to display the progression of the eye mask test in two trends, Vertical and Horizontal, in intervals of 30 seconds.

In **Vertical Trend**, the X axis represents the **Number of Acquisitions** and the Y axis represents **Vopen** in Volts. The Vertical Trend also displays **Vopen**, **Overshoot**, **Undershoot** and **Vswing** statistical results.

In **Horizontal Trend**, the X axis represents the **Number of Acquisitions** and the Y axis represents **Hopen** in seconds. The Horizontal Trend also displays the **Horizontal Opening**, **Crossover points**, **Worst Tbit** and **Tbit**.

Select the **Zoom** button to view the zoomed eye mask. Figure 3-31 is a pictorial representation of the eye diagram parameters.

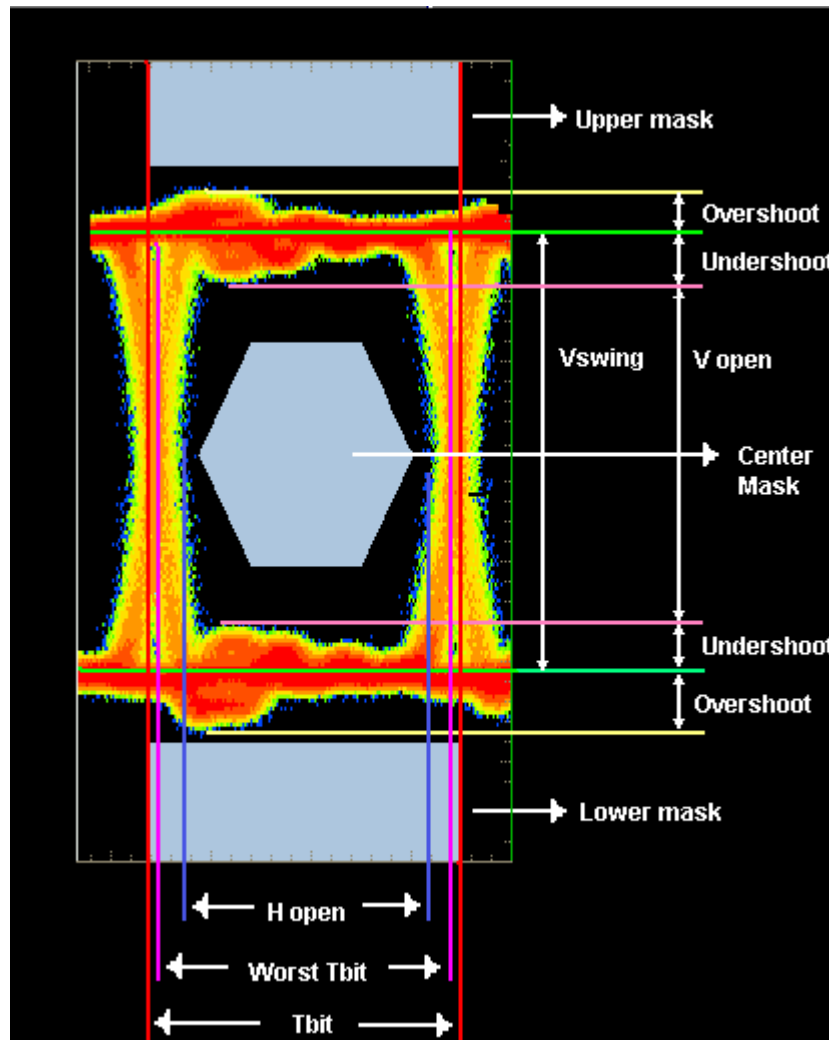

Figure 3-31: Eye definitions

Table 3-15 lists the eye trend options and their descriptions.

Table 3-15: Eye trend options and their descriptions

Option	Description
Mask	Is a set of polygons called mask segments that appears on the oscilloscope screen. If the waveform violates any one of the mask segment, the measurement fails the test; if the waveform does not violate any one of the mask segment, the measurement passes the test.
Overshoot	The voltage difference between the peak (positive or negative) and the normalized level ($V_{swing\ Low}$ or $V_{swing\ High}$) in the eye mask.
Undershoot	The voltage difference between the minimum high level voltage or the maximum low level voltage after the transition and the normalized voltage level ($V_{swing\ Low}$ or $V_{swing\ High}$) in the eye mask.
Vswing	The voltage difference between the normalized high and low levels of the eye diagram.

Tbit	The time taken to transmit one bit of data.
Worst Tbit	The minimum distance between two consecutive crossover points in the eye diagram.
Crossover	The intersection or the overlapping of the rising and falling edges in a eye diagram.

To display the trend statistics table:

- Select the **View** button to display the Statistics table as shown in Figure 3-32.

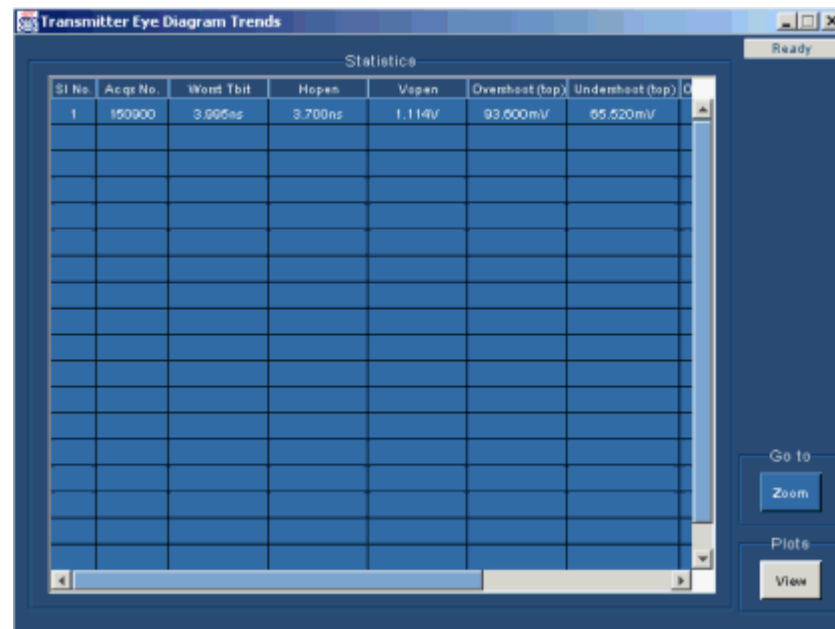

Figure 3-32: Eye trends statistical table

Table 3-16 lists the statistical table and their descriptions.

Table 3-16: Eye Trend-Statistics options and their descriptions

Option	Description
Acqs No	The number of acquisitions.
Worst Tbit	The minimum distance between two consecutive crossover points.
Hopen	The maximum horizontal opening between the closest hit points.
Vopen	The maximum vertical opening between the closest hit points.
Overshoot (Top and Bottom)	The voltage difference between the peak (positive or negative) and the normalized level (Vswing Low or Vswing High) in the eye mask.
Undershoot (Top and Bottom)	The voltage difference between the minimum high level voltage or the maximum low level voltage after the transition and the normalized voltage level (Vswing Low or Vswing High) in the eye mask.

Status	The results of the selected measurement as Pass or Fail.
--------	--

Transmitter, Cable, Receiver Screen Interface

About Transmitter, Cable, and Receiver The application tests the signals for three types of devices: Transmitter, Cable and Receiver.

- Transmitter: Is a device that transmits DVI signals.
- Cable: Is a medium that transmits DVI signals from a transmitter to a receiver.
- Receiver: Is a device that receives DVI signals.

These devices are grouped into three tabs and have different measurements associated with them.

Transmitter Eye Diagram Screen Interface

Transmitter Eye Diagram Pane Before using the application, set up the DUT as given in **Application Examples> Transmitter-Eye Diagram> Equipment** setup on page 134.

Select the Transmitter tab and click on the Eye Diagram measurement to display the following screen.

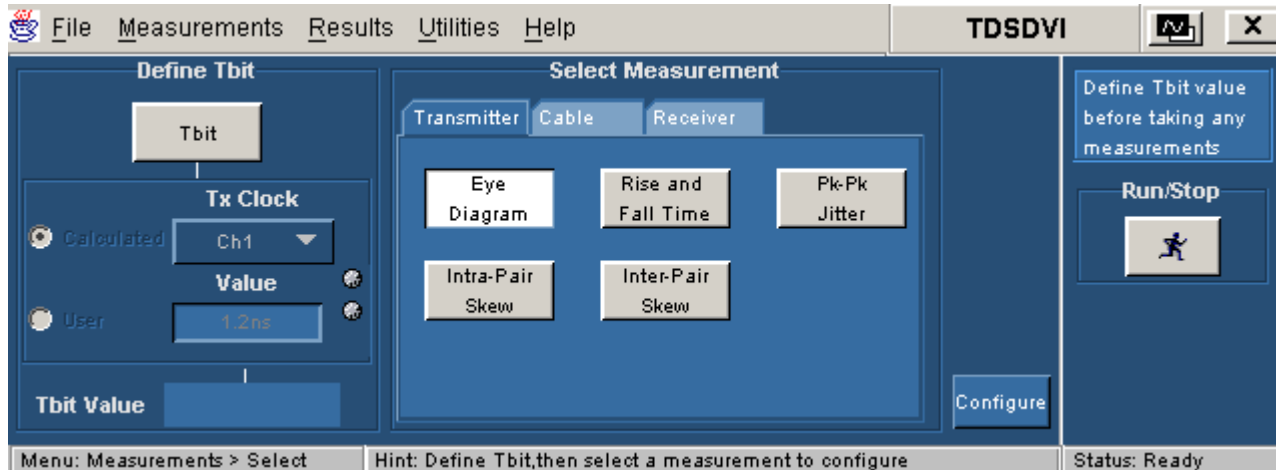

Figure 3-33: Eye Diagram pane

Configuration parameters for Eye Diagram

Select the **Eye Diagram** measurement and click the **Configure** button to display the configuration parameters for the Transmitter Eye Diagram measurement.

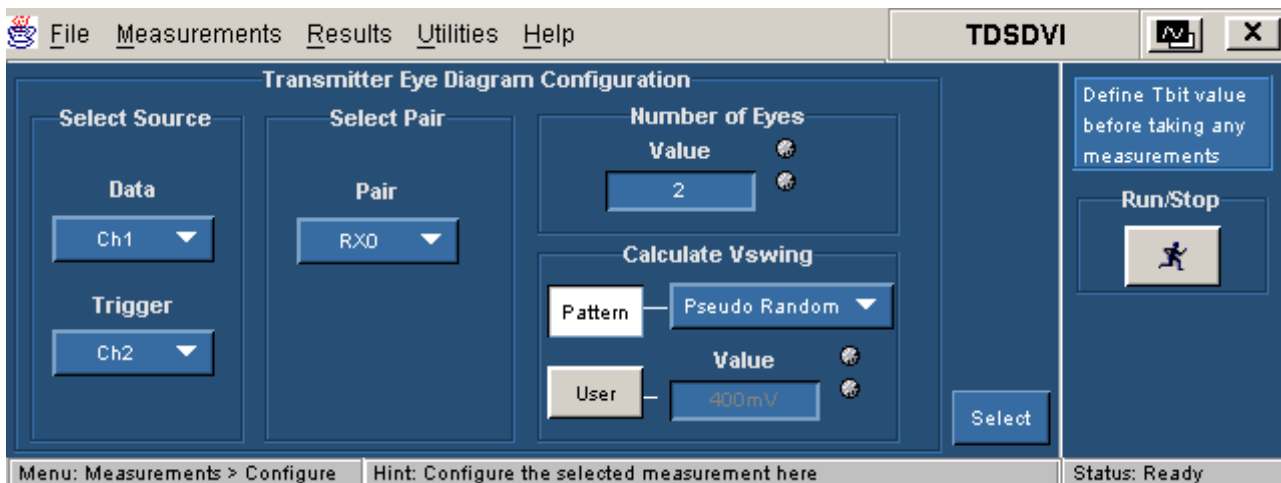

Figure 3-34: Eye Diagram Configuration

Select Source



Figure 3-35: Select source

Use the drop-down arrow in the **Data** combo box to select the data source channel. The available selections are: Ch1 to Ch4. The application requires a recovered clock as an external trigger source to the oscilloscope. Use the drop-down arrow in the **Trigger** combo box to set the trigger source channel. The Data and Trigger sources are mutually exclusive. The Data and Trigger fields identify the data source and the external clock source.

Note: You cannot select the same channel for Data and Trigger.

Select Pair



Figure 3-36: Select pair

Use the drop-down arrow in the **Select Pair** combo box to set the data pair. The available data pairs are:

- RX0
- RX1
- RX2

Select the data pair from which you have probed the TPA-P fixture.

Number of Eyes

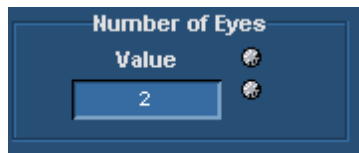



Figure 3-37: Number of eyes

Use the GP knob or the calculator keypad  next to the Value field, to set the minimum number of eyes considered to find the worst eye opening in Transmitter, Cable or Receiver Eye measurements. The application then positions the eye mask on the worst opening eye.

You can set a minimum of two eyes to place the mask on the worst eye opening because the DVI specifications recommends at least two eyes to conduct the eye diagram test.

To analyze the pixels, you can set a maximum of ten eyes because each data pixel has 10 bits. The application analyzes these eyes and places the mask at the worst eye opening.

Calculate Vswing

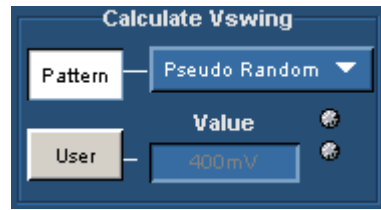

Figure 3-38: Calculate Vswing

Select the **Pattern** button to indicate the pattern you are using to calculate Vswing. The available patterns are: **Pseudo Random Pattern (PRP)** or **Half Clock Pattern (HCP)**. If you select the **User** option, use the pop-up keypad in the **Value** field to enter the **Vswing** values. The range of the Vswing value is 200 millivolts to 2 volts. The application uses the Vswing value to calculate the eye mask coordinates in Eye diagram measurement and the reference level in Rise Time and Fall Time measurement.

To calculate **Vswing**:

Select **Pseudo Random Pattern** or **Half Clock** from the drop-down list. To calculate Vswing accurately, we recommend you to use only the Half Clock Pattern because the HCP signal has less ringing compared to the PRP signal.

If you select the **Half Clock** option, the application prompts you to connect the HCP and calculate the Vswing using the HCP signal.

Select **User** option. In the **Value** field, use the calculator keypad to enter the Vswing values. The minimum value is 200 millivolts and the maximum is 2 volts. The default value is 400 mV. If you are using this option, the application will not use a signal to calculate the Vswing.

Transmitter Rise and Fall Time Screen Interface

Transmitter Rise and Fall Time Pane Before using the application, set up the DUT as given in **Application Examples> Transmitter-Rise and Fall Time> Equipment Set up** on page 137

According to the DVI specifications, Rise and Fall Time is defined as the time interval between the normalized 20% and 80% amplitude level of the TMDS (Transition Minimized Differential Signal) signal.

Select the Transmitter tab and click on the Rise and Fall Time measurement to display the following screen.

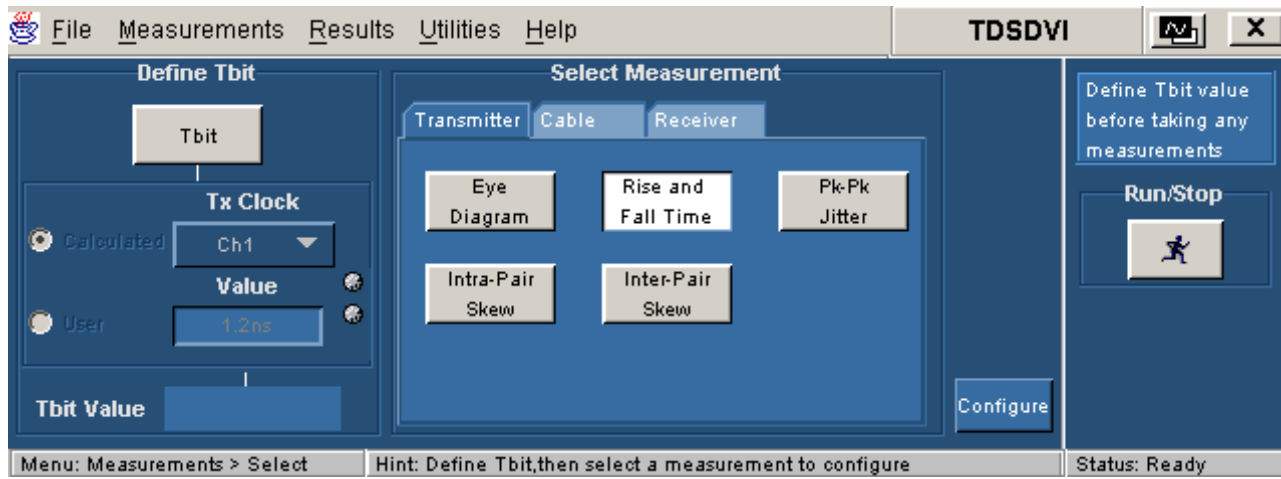

Figure 3-39: Rise and Fall Time pane

Configuration parameters for Rise and Fall Time

Select **Rise and Fall Time** measurement and select the **Configure** button to display the configuration parameters for **Rise and Fall Time** measurement.

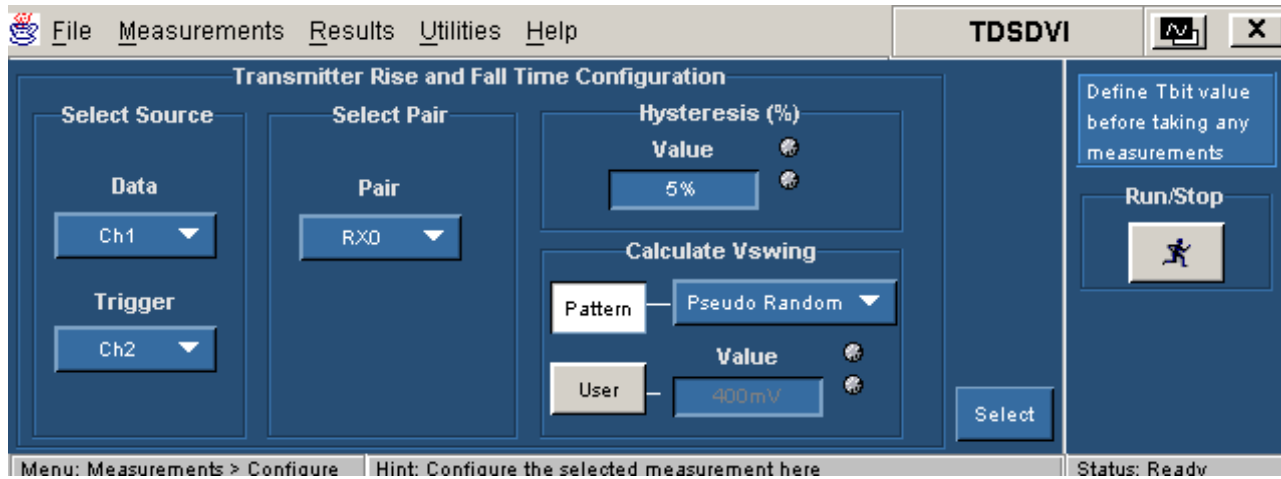

Figure 3-40: Rise and Fall Time configuration

Select Source



Figure 3-41: Select Source

Use the drop-down arrow in the **Data** combo box to select the data source channel. The available selections are: Ch1 to Ch4. The application requires a recovered clock as an external trigger source to the oscilloscope. Use the drop-down arrow in the **Trigger** combo box to set the trigger source channel. The Data and Trigger sources are mutually exclusive.

The Data and Trigger fields identify the data source and the external clock source.

Note: You cannot select the same channel for Data and Trigger.

Select Pair



Figure 3-42: Select Pair

Use the drop-down arrow in the **Select Pair** combo box to set the data pair. The available data pairs are:

- RX0
- RX1
- RX2

Select the data pair from which you have probed the TPA-P fixture.

Hysteresis

Use the GP knob or the calculator keypad  next to the Value field to enter the hysteresis percentage value. The hysteresis range is 2% to 10%.

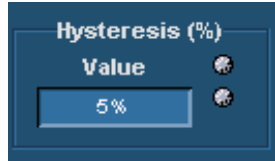

Figure 3-43: Hysteresis

Calculate Vswing

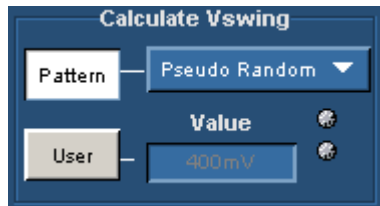

Figure 3-44: Calculate Vswing

Select the Pattern button to indicate the pattern you are using to calculate Vswing. The available patterns are: **Pseudo Random Pattern (PRP)** or **Half Clock Pattern (HCP)**. If you select the **User** option, use the pop-up keypad in the **Value** field to enter the Vswing values. The range of the Vswing value is 200 millivolts to 2 volts. The application uses the Vswing value to calculate the eye mask coordinates in Eye diagram measurement and the reference level in Rise Time and Fall Time measurement.

To calculate **Vswing**:

Select **Pseudo Random Pattern** or **Half Clock** from the drop-down list. To calculate Vswing accurately, we recommend you to use only the Half Clock Pattern because the HCP signal has less ringing compared to the PRP signal.

If you select the **Half Clock** option, the application prompts you to connect the HCP and calculate the Vswing using the HCP signal.

Select **User** option. In the **Value** field, use the calculator keypad to enter the Vswing values. The minimum value is 200 millivolts and the maximum is 2 volts. The default value is 400 mV. If you are using this option, the application will not use a signal to calculate the Vswing.

Transmitter Pk-Pk Jitter Screen Interface

Transmitter Pk-Pk Jitter Pane Before using the application, set up the DUT as given in **Application Examples> Transmitter-Pk-Pk Jitter> Equipment Setup** on page 140.

Select the Transmitter tab and click on the Pk-Pk Jitter measurement to display the following screen.

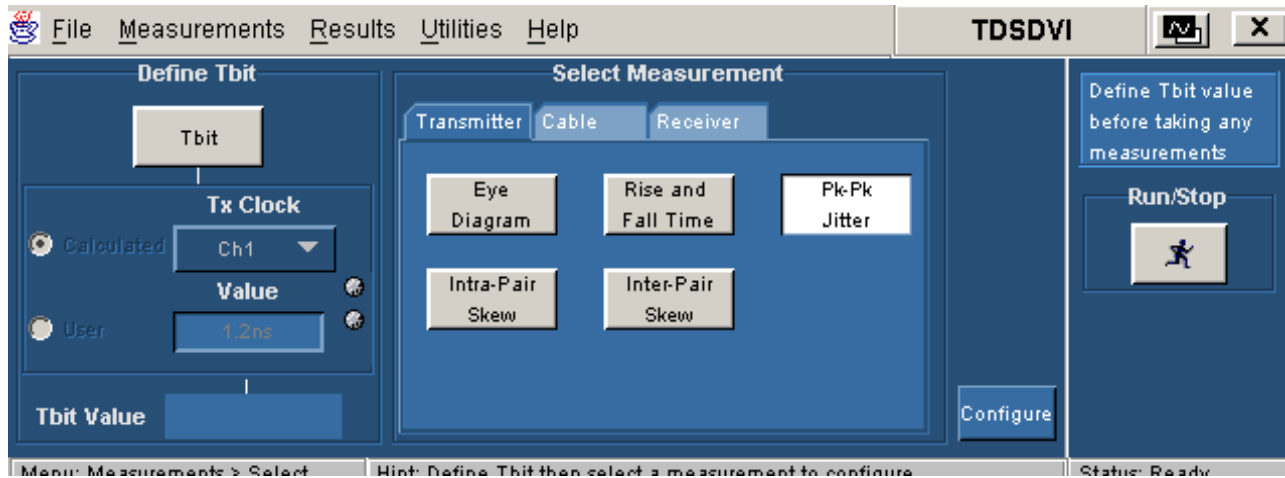

Figure 3-45: Pk-Pk Jitter pane

Configuration parameters for Pk-Pk Jitter

Select the **Pk-Pk Jitter** measurement and press the **Configure** button to display the configuration parameters for the **Pk-Pk Jitter** measurement.

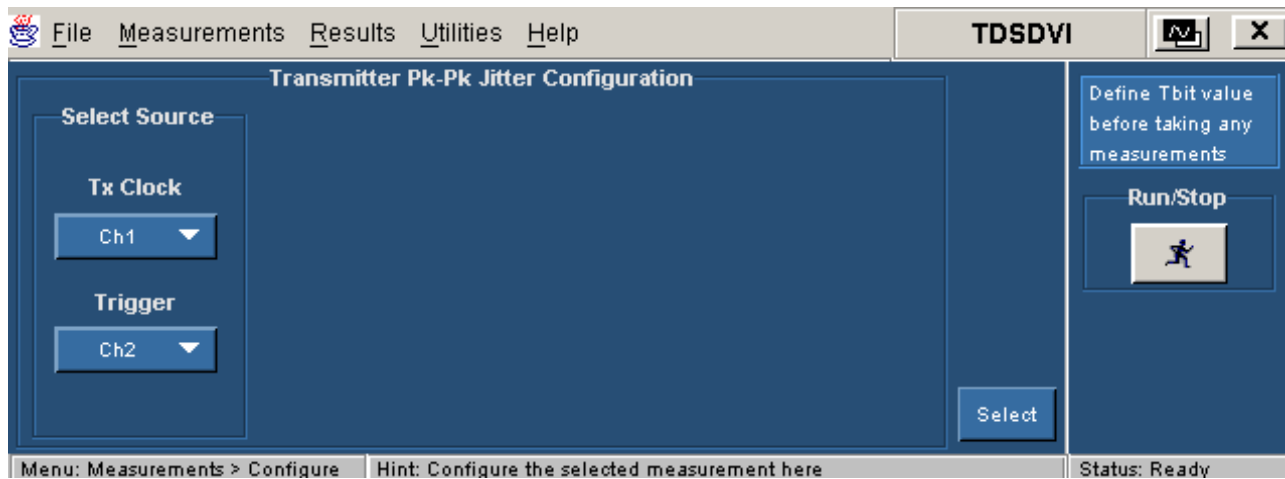

Figure 3-46: Pk-Pk Jitter configuration

Select Source

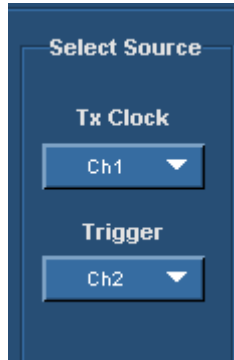

Figure 3-47: Select Source

Use the drop-down arrow in the **Tx Clock** combo box to select the transmitted differential clock source channel. The available selections are: Ch1 to Ch4. The application requires a CRU (Clock Recovery Unit) to trigger the oscilloscope. Use the drop-down arrow in the **Trigger** combo box to set the trigger source channel. Data and Trigger source are mutually exclusive.

The Tx Clock and Trigger fields identify the Tx clock source and the Clock Recovery Unit source.

***Note:** You cannot select the same channel for Tx clock and Trigger.*

Transmitter Intra-Pair Skew Screen Interface

Transmitter Intra-Pair Skew Pane Before using the application, set up the DUT as given in **Application Examples> Transmitter-Intra-Pair Skew> Equipment Setup** on page 150.

Intra-Pair skew is the Skew between the signal that constitutes from the same pair (Example Rx0+ and Rx0-) at TP2.

Select the Transmitter tab and click on Intra-Pair Skew measurement to display the following screen.

Configuration parameters for Intra-Pair Skew

Select the **Intra-Pair Skew** measurement and press the Configure button to display the configuration parameters for the **Intra-Pair Skew** measurement.

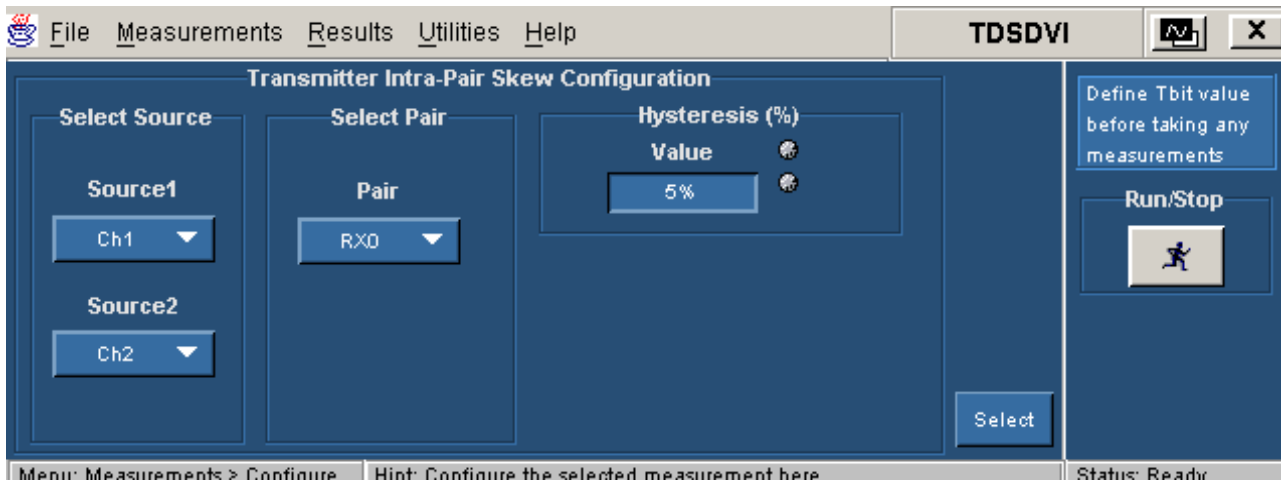

Figure 3-48: Intra-Pair Skew configuration

Select Source



Figure 3-49: Select Source

Use the drop-down arrow in the **Source1** combo box to set the data line (+) of the data pair. The available selections are: Ch1 to Ch4. Use the drop-down arrow in the **Source2** combo box to set the data line (-) of the data pair. The Source channels are mutually exclusive. Use two single-ended probes to connect the data pair (for example: Rx0+ or Rx0-) to Source1 and Source2.

The Source field identifies a data line.

Note: You cannot select the same channel for Source1 and Source2.

Select Pair



Figure 3-50: Select Pair

Use the drop-down arrow in the **Select Pair** combo box to set the data pair. The available data pairs are:

- RX0
- RX1
- RX2

Select the data pair to which you have probed the TPA-P fixture for Transmitter device and TPA-R fixture for a Cable and Receiver device.

Hysteresis

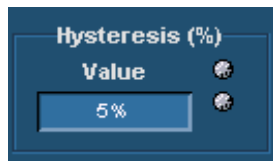

Figure 3-51: Hysteresis

Use the GP knob or the calculator keypad  next to the Value field to enter the hysteresis percentage value.

The hysteresis range is 2% to 10%.

Transmitter Inter-Pair Skew Screen Interface

Transmitter Inter-Pair Skew Pane Before using the application, set up the DUT as given in **Application Examples> Transmitter-Inter-Pair Skew> Equipment Setup** on page 146.

Inter-pair skew is the time delay between the different data pairs (Example Rx0+ of one pair and Rx1- of the other pair).

Select the Transmitter tab and click on the Inter-Pair Skew measurement to display the following screen.

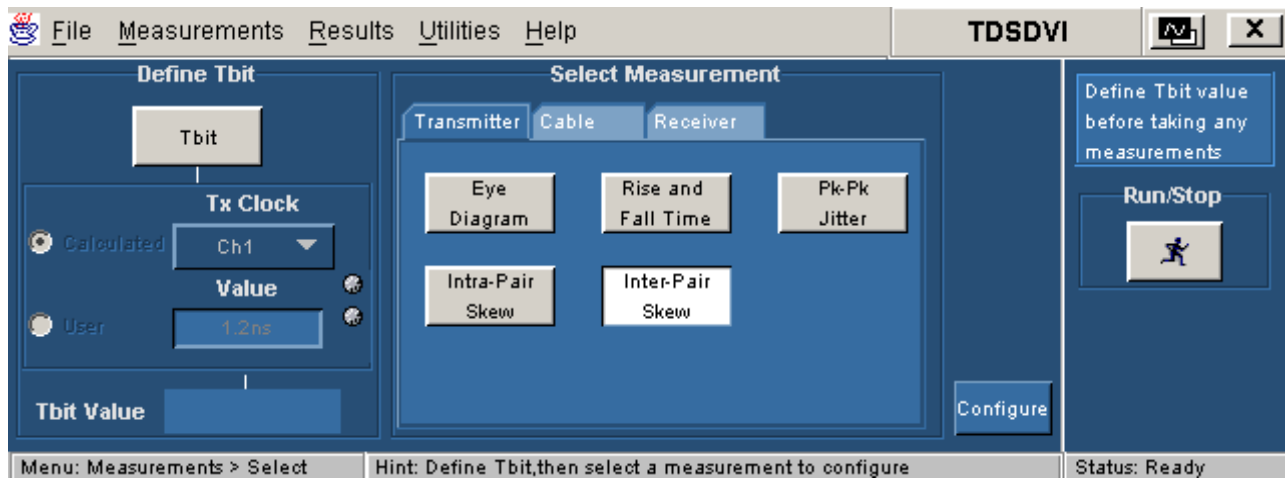

Figure 3-52: Inter-Pair Skew pane

Configuration parameters for Inter-Pair Skew

Select the **Inter-Pair Skew** measurement and press the **Configure** button to display the configuration parameters for the **Inter-Pair Skew** measurement.

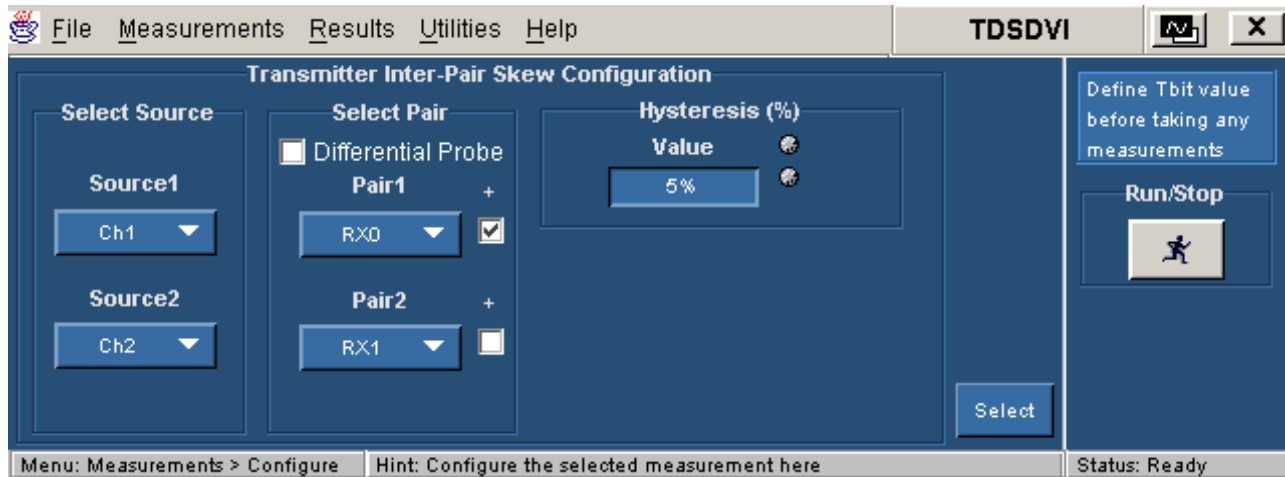

Figure 3-53: Inter-Pair Skew configuration

Select Source

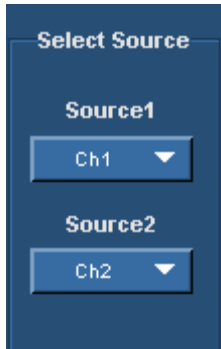

Figure 3-54: Select Source

Use the drop-down arrow in the **Source1** combo box to set the data line (+) of the data pair. The available selections are: Ch1 to Ch4. Use the drop-down arrow in the **Source2** combo box to set the data line (-) of the data pair. The Source channels are mutually exclusive. Use two single-ended probes to connect the data pair (for example: Rx0+ or Rx0-) to Source1 and Source2.

The Source field identifies a data line.

Note: You cannot select the same channel for Source1 and Source2.

Select Pair

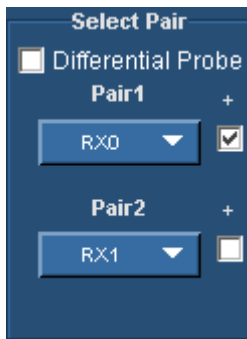

Figure 3-55: Select Pair

Use the drop-down arrow in the **Pair1** and **Pair2** combo box to set the differential data pair. The available data pairs are:

- RX0
- RX1
- RX2

If the data line is positive, select the check box next to the Pair fields. If you select the Differential Probe check box, the positive check boxes next to the pair fields are disabled and the application calculates the time delay between the two data pairs. If you used a single-ended probe, the application calculates the skew between the data lines.

Select the data pair from which you have probed the TPA-P fixture. You cannot select the same data pair in the **Pair1** and **Pair2** combo boxes irrespective of the polarity (+ or -).

Hysteresis

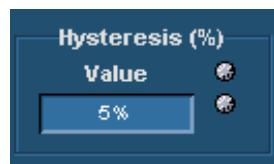

Figure 3-56: Hysteresis

Use the GP knob or the calculator keypad  next to the Value field to enter the hysteresis percentage value.

The hysteresis range is 2% to 10%.

Cable High-Amplitude/Low Amplitude Eye Diagram Screen Interface

Cable High-Amplitude Eye Diagram Pane Before using the application, set up the DUT as given in **Application Examples > Cable-High-Amplitude/Low Amplitude Eye Diagram > Equipment Setup** on page 155.

Select the Cable tab and click on the High-Amp Eye Diagram measurement to display the following screen.

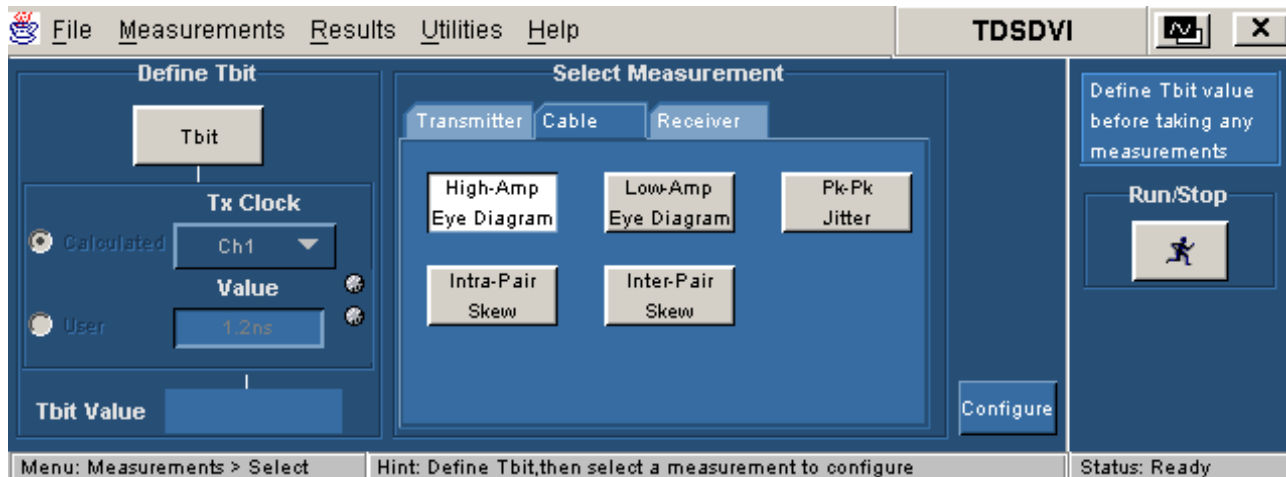

Figure 3-57: High-Amplitude Eye Diagram pane

Configuration parameters for Eye

Select the **High-Amplitude Eye Diagram** measurement and press the **Configure** button to display the configuration parameters for **High-Amplitude Eye Diagram** measurement.

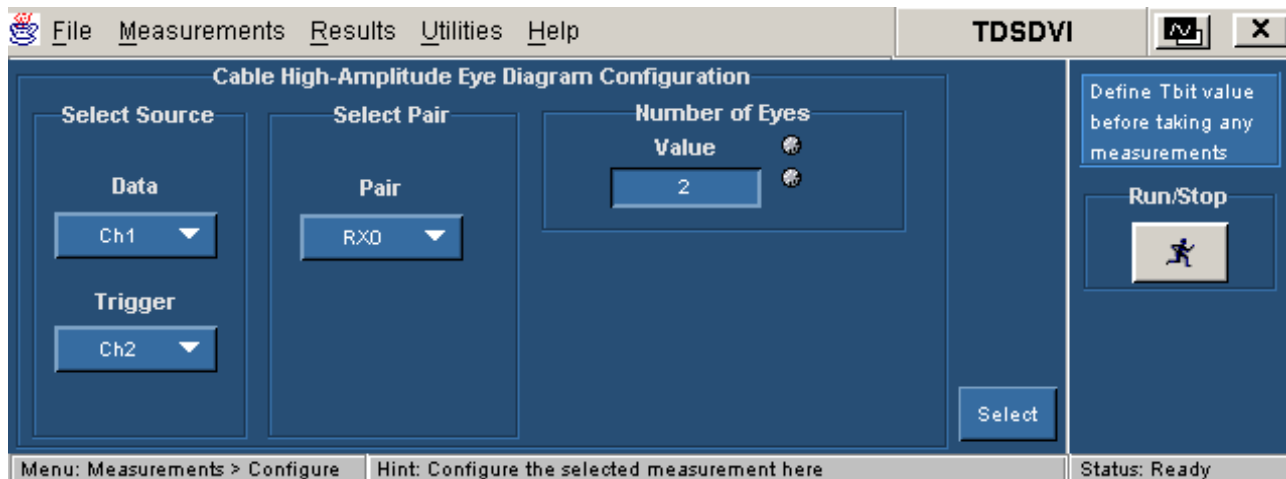

Figure 3-58: High-Amplitude Eye Diagram configuration

Cable Low-Amplitude Eye Diagram Pane Before using the application, set up the DUT as given in **Application Examples> Transmitter-Eye Diagram> Equipment Setup** on page 155.

Select the Cable tab and click on the Low-Amp Eye Diagram measurement to display the following screen.

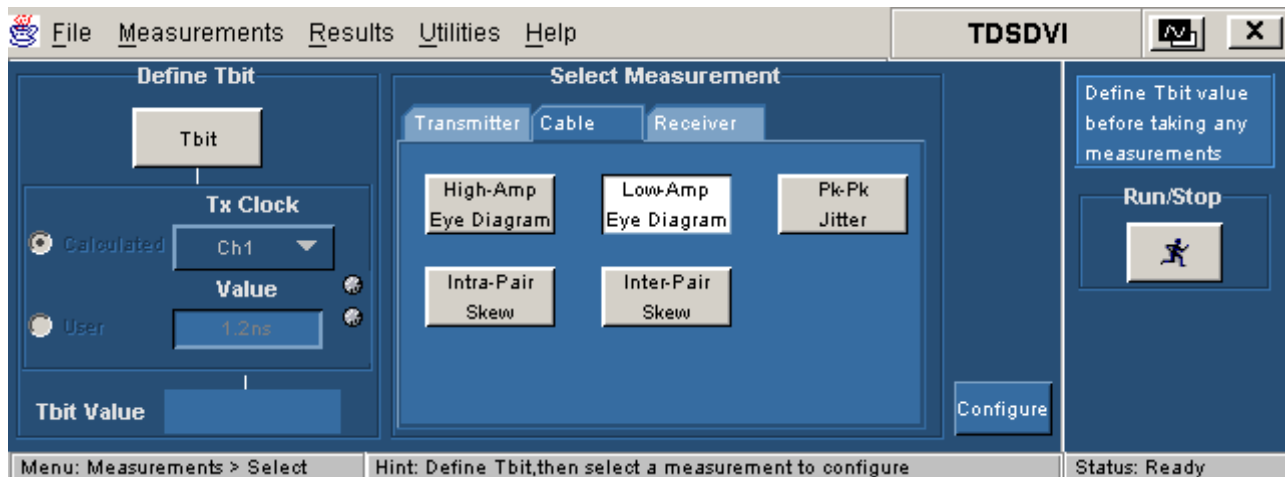

Figure 3-59: Low-Amplitude Eye Diagram pane

Configuration parameters for Low-Amplitude Eye Diagram

Select the **Low-Amplitude Eye Diagram** measurement and press the **Configure** button to display the configuration parameters for **Low-Amplitude Eye Diagram** measurement.

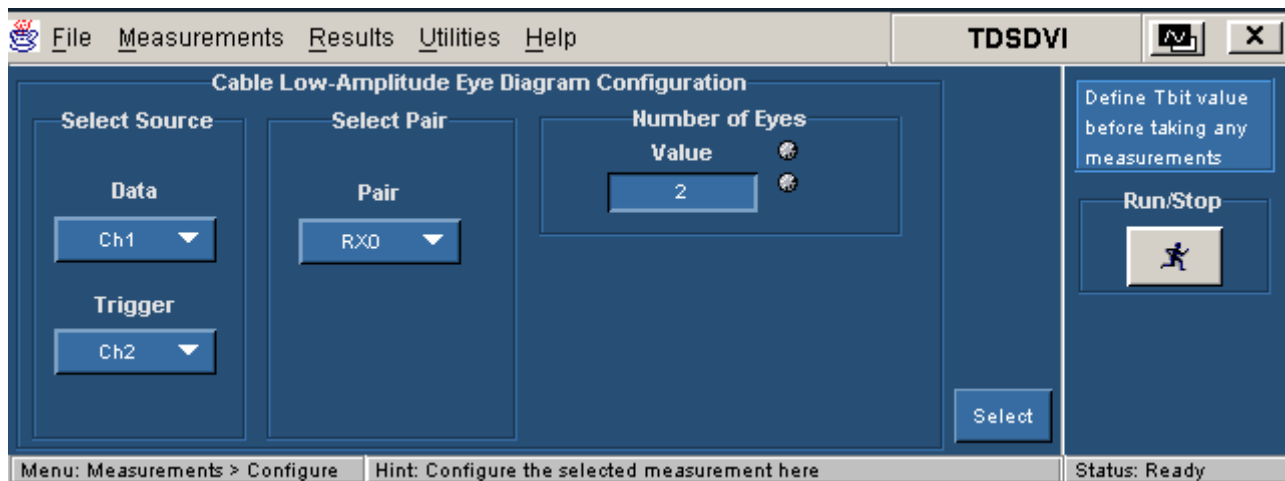

Figure 3-60: Low-Amplitude Eye Diagram configuration

Select Source

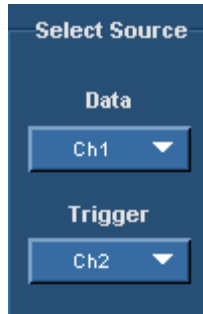

Figure 3-61: Select Source

Use the drop-down arrow in the **Data** combo box to select the data source channel. The available selections are: Ch1 to Ch4. The application requires a recovered clock as an external trigger source to the oscilloscope. Use the drop-down arrow in the **Trigger** combo box to set the trigger source channel. The Data and Trigger sources are mutually exclusive.

The Data and Trigger fields identify the data source and the external clock source.

***Note:** You cannot select the same channel for Data and Trigger.*

Select Pair



Figure 3-62: Select Pair

Use the drop-down arrow in the **Select Pair** combo box to set the data pair. The available data pairs are:

- RX0
- RX1
- RX2

Select the data pair to which you have probed the TPA-P fixture for Transmitter device and TPA-R fixture for a Cable and Receiver device.

Number of Eyes



Figure 3-63: Number of Eyes

Use the GP knob or the calculator keypad  next to the Value field, to set the minimum number of eyes considered to find the worst eye opening in Transmitter, Cable or Receiver Eye measurements. The application then positions the eye mask on the worst opening eye.

You can set a minimum of two eyes to place the mask on the worst eye opening because the DVI specifications recommends at least two eyes to conduct the eye diagram test.

To analyze the pixels, you can set a maximum of ten eyes because each data pixel has 10 bits. The application analyzes these eyes and places the mask at the worst eye opening.

Cable Pk-Pk Jitter Screen Interface

Cable Pk-Pk Jitter Setup Pane Before using the application, set up the DUT as given in **Application Examples> Cable-Pk-Pk Jitter> Equipment Setup** on page 149.

Select the Cable tab and click on the Pk-Pk Jitter measurement to display the following screen.

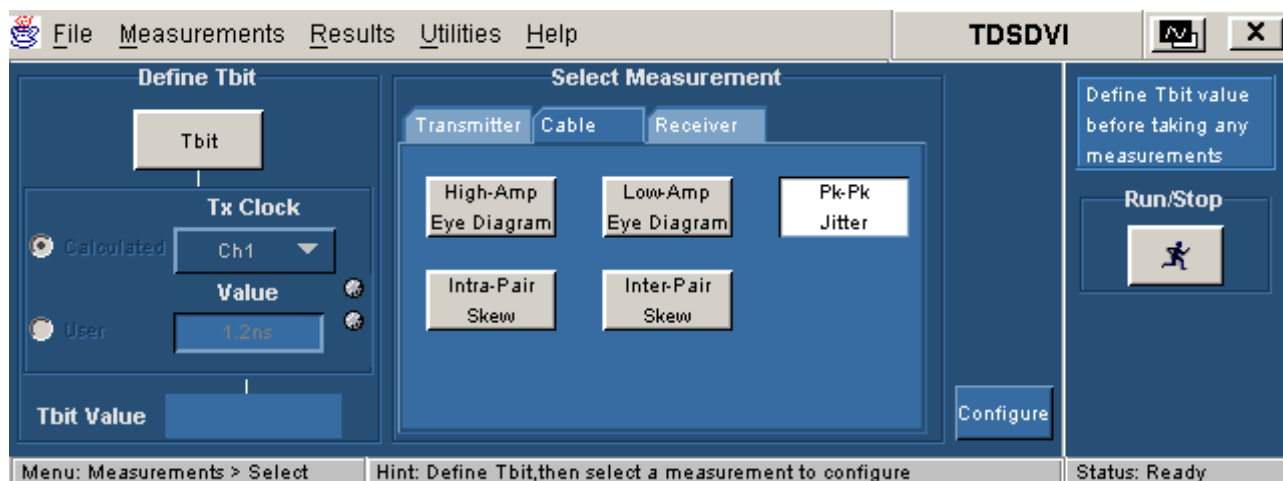

Figure 3-64: Pk-Pk Jitter pane

Configuration parameters for Pk-Pk Jitter

Select the **Pk-Pk Jitter** measurement and press the **Configure** button to display the configuration parameters for the **Pk-Pk Jitter** measurement.

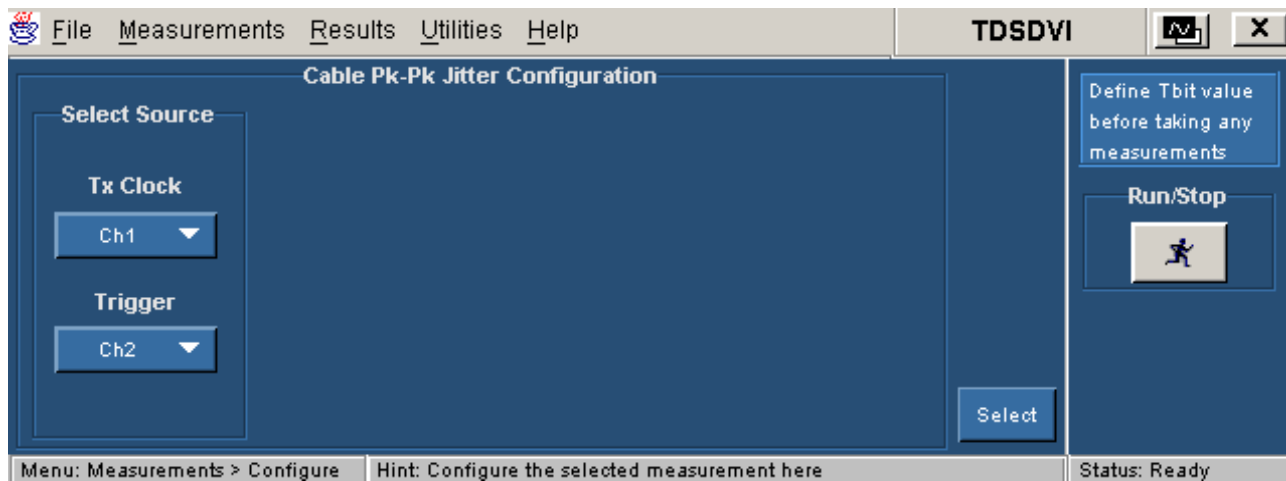

Figure 3-65: Pk-Pk Jitter configuration

Select Source

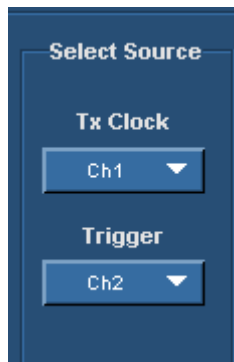

Figure 3-66: Select Source

Use the drop-down arrow in the **Tx Clock** combo box to select the transmitted differential clock source channel. The available selections are: Ch1 to Ch4. The application requires a CRU (Clock Recovery Unit) to trigger the oscilloscope. Use the drop-down arrow in the **Trigger** combo box to set the trigger source channel. Data and Trigger source are mutually exclusive.

The Tx Clock and Trigger fields identify the Tx clock source and the Clock Recovery Unit source.

Note: You cannot select the same channel for Tx clock and Trigger.

Cable Intra-Pair Skew Screen Interface

Cable Intra-Pair Skew Setup Pane Before using the application, set up the DUT as given in **Application Examples> Cable-Intra-Pair Skew> Equipment Setup** on page 150.

Cable Intra-Pair skew is the skew between the signal that constitutes from the same pair (Example Rx0+ and Rx0-) at TP3.

Select the Cable tab and click on the Intra-Pair Skew measurement to display the following screen measurement.

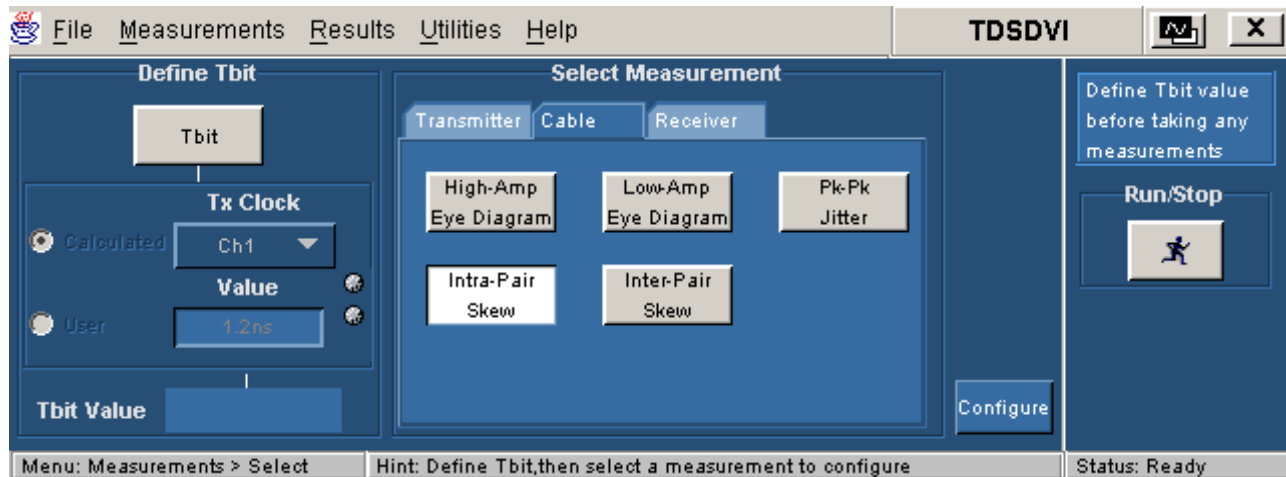

Figure 3-67: Intra-Pair Skew pane

Configuration parameters for Intra-Pair Skew

Select the **Intra-Pair Skew** measurement and press the **Configure** button to display the configuration parameters for the **Intra-Pair Skew** measurement.

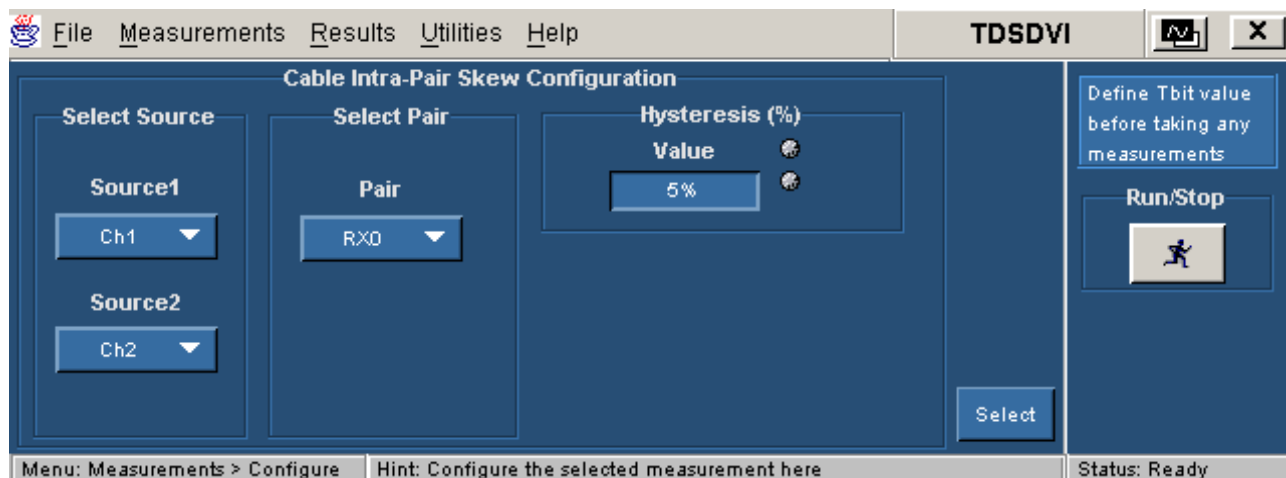

Figure 3-68: Intra-Pair Skew Configuration

Select Source

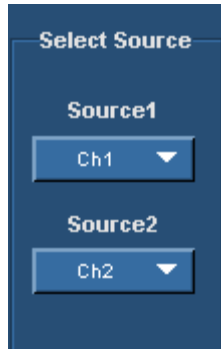

Figure 3-69: Select Source

Use the drop-down arrow in the **Source1** combo box to set the data line (+) of the data pair. The available selections are: Ch1 to Ch4. Use the drop-down arrow in the **Source2** combo box to set the data line (-) of the data pair. The Source channels are mutually exclusive. Use two single-ended probes to connect the data pair (for example: Rx0+ or Rx0-) to Source1 and Source2.

The Source field identifies a data line.

***Note:** You cannot select the same channel for Source1 and Source2.*

Select Pair



Figure 3-70: Select Pair

Use the drop-down arrow in the **Select Pair** combo box to set the data pair. The available data pairs are:

- RX0
- RX1
- RX2

Select the data pair to which you have probed the TPA-P fixture for Transmitter device and TPA-R fixture for a Cable and Receiver device.

Hysteresis

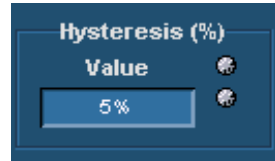

Figure 3-71: Hysteresis

Use the GP knob or the calculator keypad  next to the Value field to enter the hysteresis percentage value.

The hysteresis range is 2% to 10%.

Cable Inter-Pair Skew Screen Interface

Cable Inter-Pair Skew Setup Pane Before using the application, set up the DUT as given in **Application Examples> Cable-Inter-Pair Skew> Equipment Setup** on page 153.

Inter-Pair skew is the skew between the signal that constitutes from the different pair (Example Rx0+ of one pair and Rx0- of the other pair).

Select the Cable tab and click on the Inter-Pair Skew measurement to display the following screen.

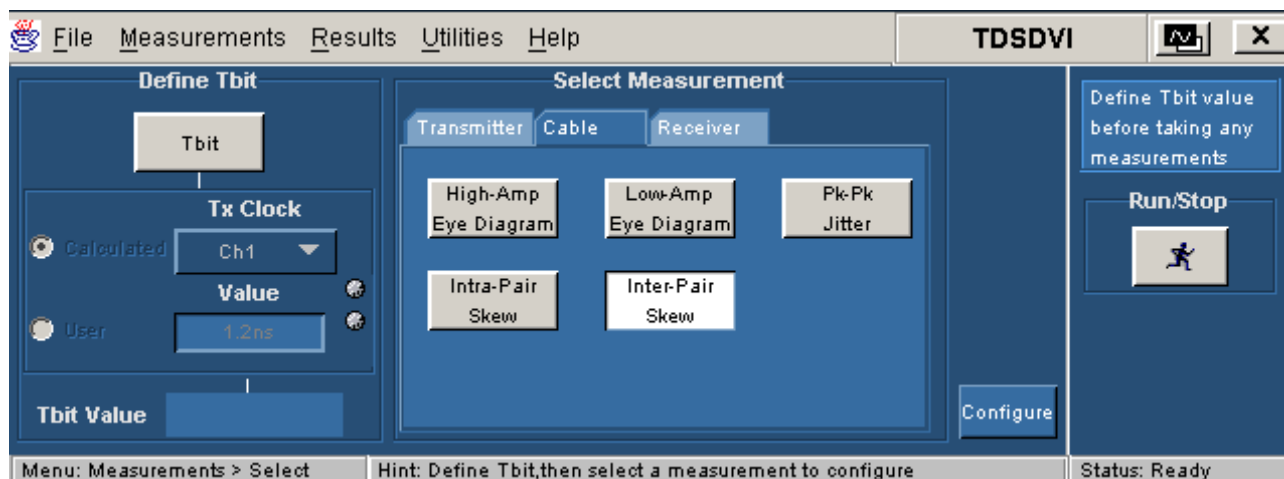

Figure 3-72: Inter-Pair Skew pane

Configuration parameters for Inter-Pair Skew

Select the **Inter-Pair Skew** measurement and press the **Configure** button to display the configuration parameters for the **Inter-Pair Skew** measurement.

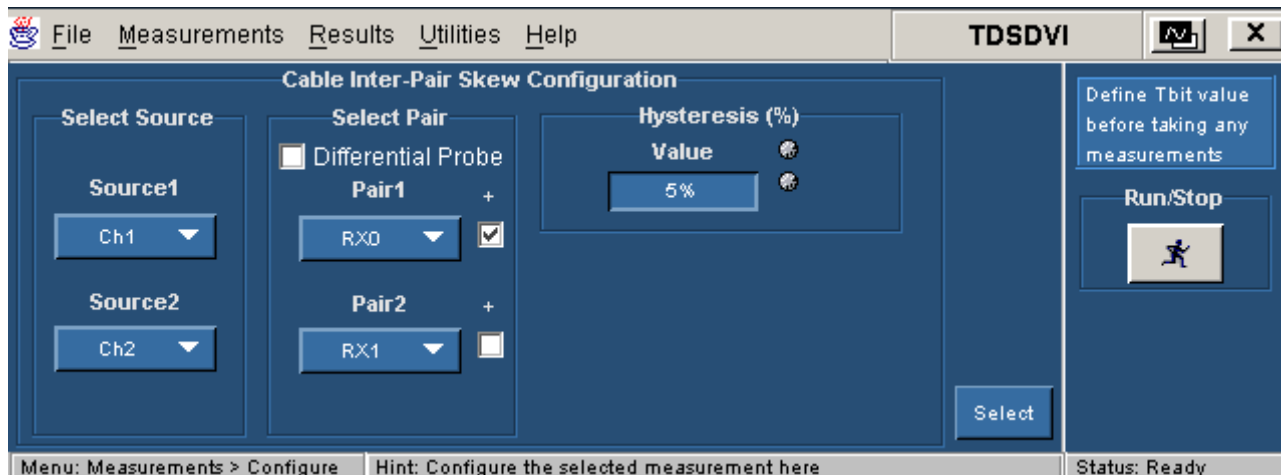

Figure 3-73: Inter-Pair Skew configuration

Select Source

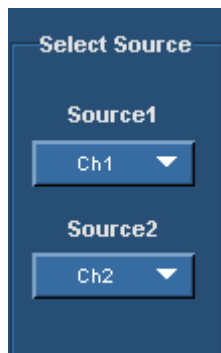

Figure 3-74: Select Source

Use the drop-down arrow in the **Source1** combo box to set the data line (+) of the data pair. The available selections are: Ch1 to Ch4. Use the drop-down arrow in the **Source2** combo box to set the data line (-) of the data pair. The Source channels are mutually exclusive. Use two single-ended probes to connect the data pair (for example: Rx0+ or Rx0-) to Source1 and Source2.

The Source field identifies a data line.

Note: You cannot select the same channel for Source1 and Source2.

Select Pair

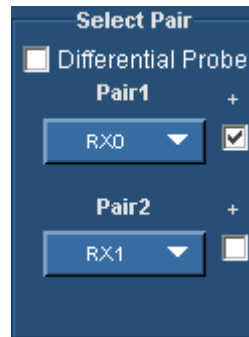

Figure 3-75: Select Pair

Use the drop-down arrow in the **Pair1** and **Pair2** combo box to set the differential data pair. The available data pairs are:

- RX0
- RX1
- RX2

If the data line is positive, select the check box next to the Pair fields. If you select the Differential Probe check box, the positive check boxes next to the pair fields are disabled and the application calculates the time delay between the two data pairs. If you used a single-ended probe, the application calculates the skew between the data lines.

Select the data pair from which you have probed the TPA-P fixture. You cannot select the same data pair in the **Pair1** and **Pair2** combo boxes irrespective of the polarity (+ or -).

Hysteresis



Figure 3-76: Hysteresis

Use the GP knob or the calculator keypad  next to the Value field to enter the hysteresis percentage value.

The hysteresis range is 2% to 10%.

Receiver High-Amplitude/Low Amplitude Eye Diagram Screen Interface

Receiver High-Amplitude Eye Diagram Pane

Before using the application, set up the DUT as given in **Application Examples> Receiver-High Amplitude/Low Amplitude Eye Diagram> Equipment Setup** on page 160.

Select the Receiver tab and click on the High-Amp Eye Diagram measurement to display the following screen.

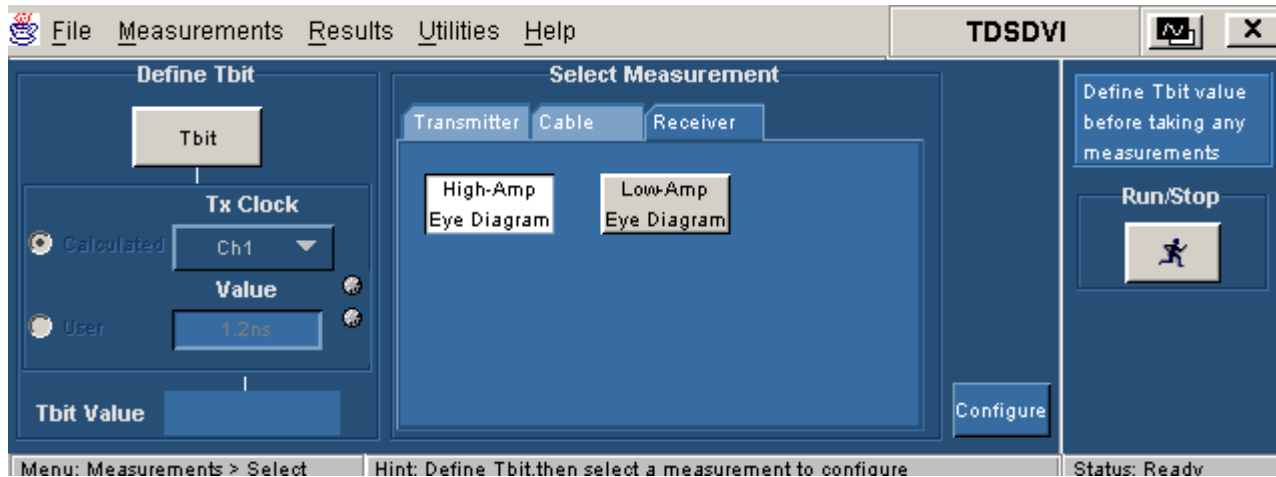

Figure 3-77: High-Amplitude Eye Diagram pane

Configuration parameters for High-Amplitude Eye Diagram

Select the **High-Amplitude Eye Diagram** and press the **Configure** button to display the configuration parameters for the **High-Amplitude Eye Diagram** measurement.

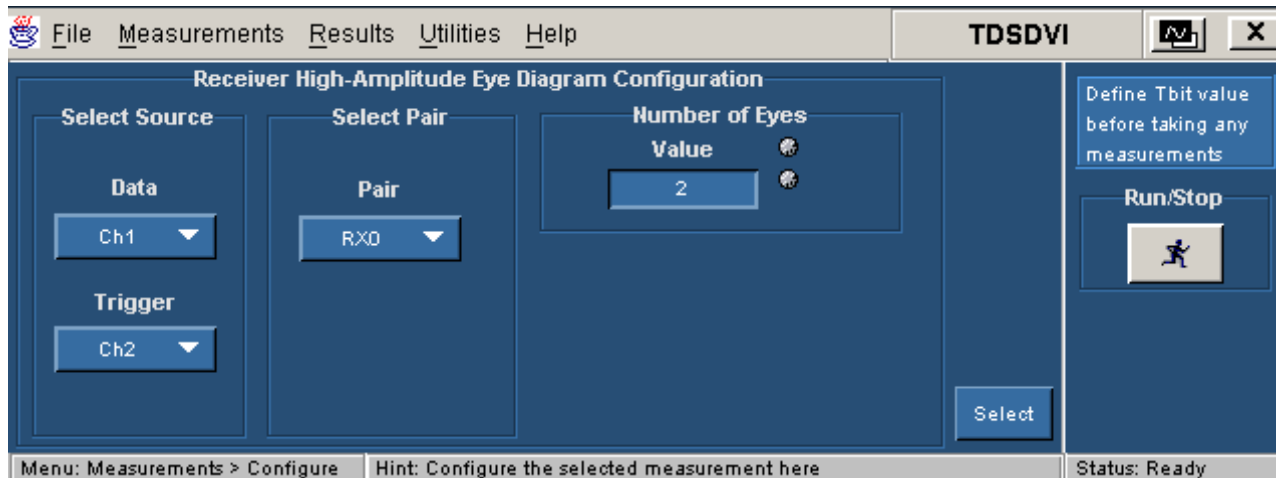

Figure 3-78: High-Amplitude Eye Diagram configuration

Receiver Low-Amplitude Eye Diagram Pane

Before using the application, set up the DUT as given in **Receiver-High Amplitude/Low Amplitude Eye Diagram> Equipment Setup** on page 160.

Select the Receiver tab and click on the Low-Amp Eye Diagram measurement to display the following screen.

Configuration parameters for Low-Amplitude Eye Diagram

Select the **Low-Amplitude Eye Diagram** and press the **Configure** button to display the configuration parameters for the **Low-Amplitude Eye Diagram** measurement.

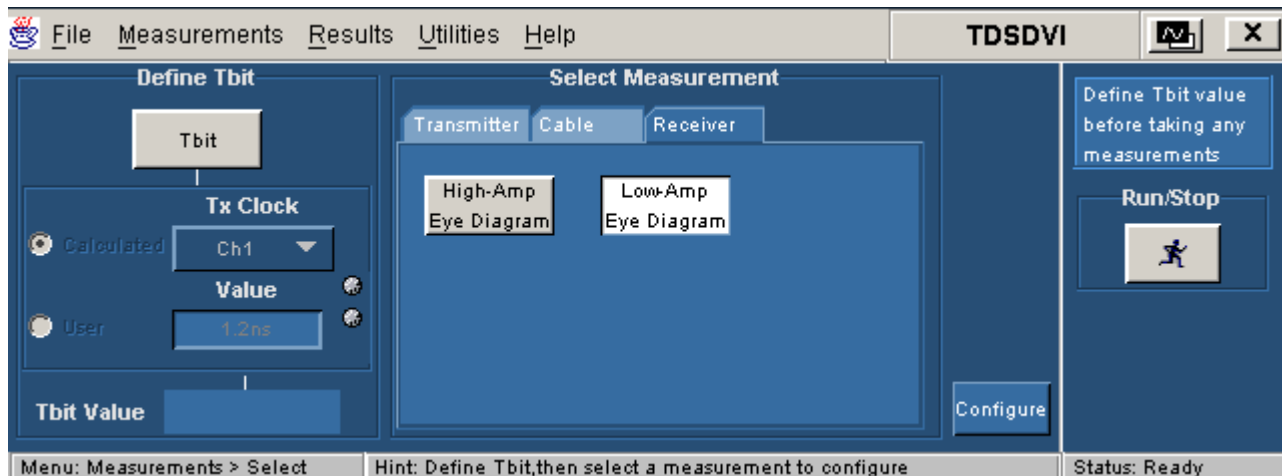

Figure 3-79: Low-Amplitude pane

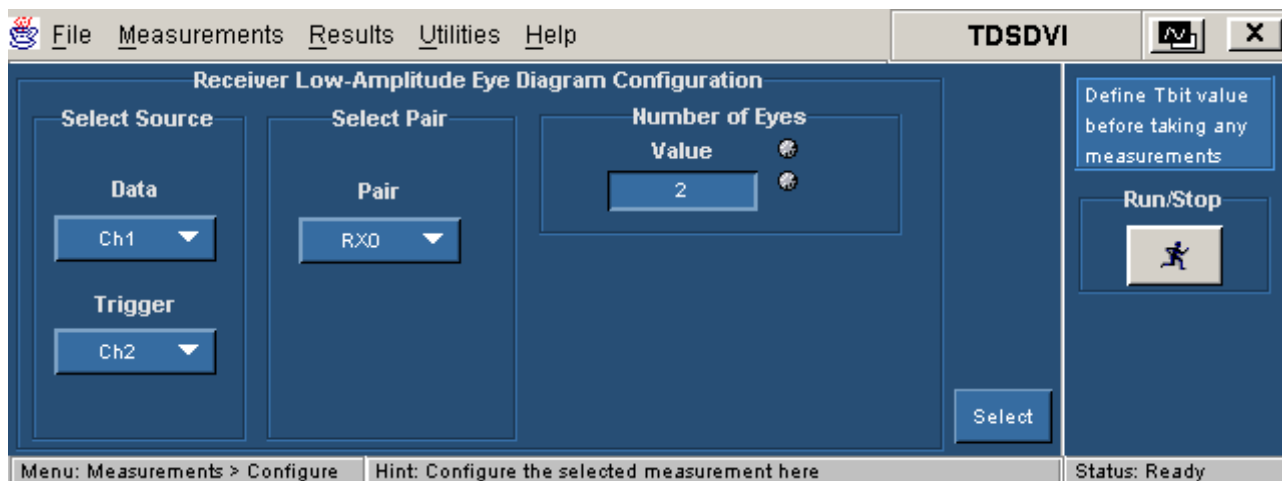

Figure 3-80: Low-Amplitude configuration

Select Source



Figure 3-81: Select Source

Use the drop-down arrow in the **Data** combo box to select the data source channel. The available selections are: Ch1 to Ch4. The application requires a recovered clock as an external trigger source to the oscilloscope. Use the drop-down arrow in the **Trigger** combo box to set the trigger source channel. The Data and Trigger sources are mutually exclusive.

The Data and Trigger fields identify the data source and the external clock source.

***Note:** You cannot select the same channel for Data and Trigger.*

Select Pair



Figure 3-82: Select Pair

Use the drop-down arrow in the **Select Pair** combo box to set the data pair. The available data pairs are:

- RX0
- RX1
- RX2

Select the data pair to which you have probed the TPA-P fixture for Transmitter device and TPA-R fixture for a Cable and Receiver device.

Number of Eyes



Figure 3-83: Number of Eyes

Use the GP knob or the calculator keypad  next to the Value field, to set the minimum number of eyes considered to find the worst eye opening in Transmitter, Cable or Receiver Eye measurements. The application then positions the eye mask on the worst opening eye.

You can set a minimum of two eyes to place the mask on the worst eye opening because the DVI specifications recommends at least two eyes to conduct the eye diagram test.

To analyze the pixels, you can set a maximum of ten eyes because each data pixel has 10 bits. The application analyzes these eyes and places the mask at the worst eye opening.

How to Calculate Tbit

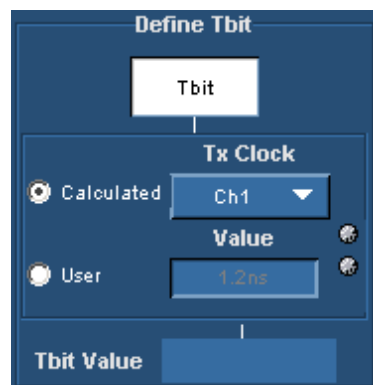

Figure 3-84: Define Tbit pane

Tbit is the time required to transmit one bit of data. The **Define Tbit** pane is independent of all the measurements. A valid Tbit value is required for all measurements. If the device, resolution, blanking rate, or the refresh rate changes, you have to recalculate Tbit. The Tx Clock field identifies the external clock source.

***Note:** We recommend that you calculate the Tbit with the differential transmitted clock rather than defining Tbit values yourself. You need to calculate Tbit only once for a device working at a particular resolution, refresh rate or the blanking rate. This value will be retained for further measurements. If the device, resolution, refresh rate or the blanking rate changes, you have to recalculate Tbit.*

To calculate Tbit,

1. Select the **Tbit** button to enable the **Define Tbit** pane.
2. Select the **Calculated** radio button to use the differential transmitted clock and calculate Tbit.
3. Select the Tx Clock channel from the **Tx Clock** drop-down list. The available selections are: Ch1 to Ch4.
4. Click the **Run** button to calculate Tbit. The application displays the following message box. (This message box is not displayed if you have not selected the **File> Preferences> Prompt for signal connection** check box.)

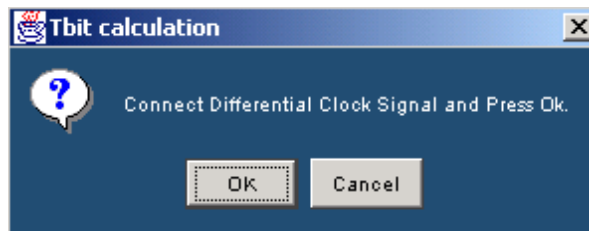

Figure 3-85: Connect differential clock message box

5. Select OK to confirm the connection and display the previous screen. You can select the Cancel button to cancel the process.
6. After calculating Tbit, the application displays the following message box and the value in the Tbit Value field.

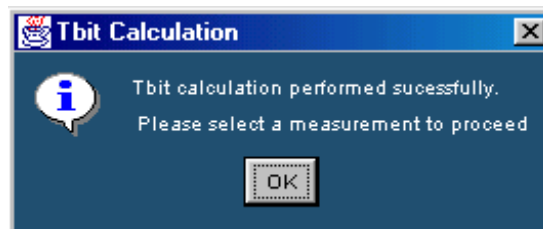

Figure 3-86: Successful Tbit calculation message box

Enter a User Defined Tbit Value

1. Select the Tbit button to enable the Define Tbit pane.
2. Select the User radio button if you want to define the Tbit values yourself.
3. Use the calculator keypad or the GP knob next to the Value field to set the Tbit value.

The acceptable ranges for Tbit Values are:

- TDS66604, TDS6404, TDS6604B, TDS6804B, TDS7404, TDS7404B, TDS7704B, CSA7404, CSA7404B oscilloscopes—200 ps to 20 ns.
- TDS7254 and TDS7254B oscilloscopes—1ns to 20 ns.

Troubleshooting Tbit Calculation Error Messages

The application displays the next message box if the Tbit value is not within the specified range. The acceptable ranges for Tbit Values are:

- TDS66604, TDS6404, TDS6604B, TDS6804B, TDS7404, TDS7404B, TDS7704B, CSA7404, CSA7404B oscilloscopes—200 ps to 20 ns.
- TDS7254 and TDS7254B oscilloscopes—1ns to 20 ns.

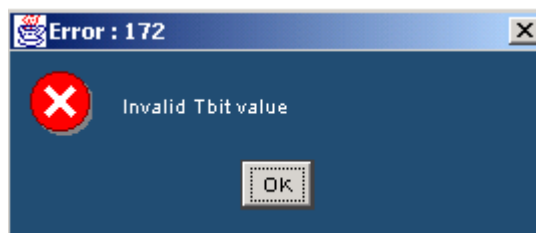

Figure 3-87: Invalid Tbit value message box

- The application displays the following message box if the Tbit calculation has failed. This happens if you have not used a clock signal.

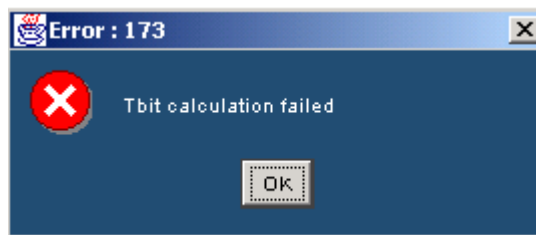

Figure 3-88: Tbit calculation failure message box

- If you select the Tbit option and press the Configure button, the application displays the following message box. To avoid this, configure the Tbit value in the Define Tbit pane and press the Run button.

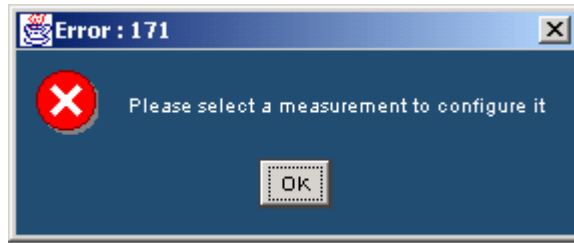

Figure 3-89: Select measurement message box

- If you select the User option and press the Configure button, the application displays the following message box.

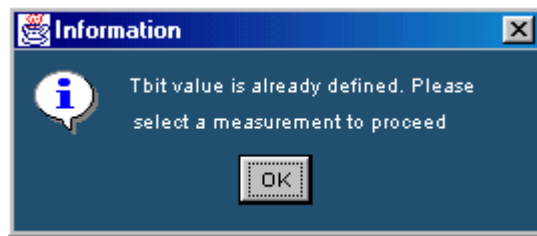

Figure 3-90: Tbit defined message box

See Also

Equipment for Tbit on page 131

Equipment setup for Tbit on page 131

How to Test Transmitter For Eye Diagram

Selecting and Configuring Measurement: Eye Diagram

Follow these steps to select and configure the Eye Diagram:

Note: Refer page 134 to set up the DUT before using the application.

1. Select **Measurements> Select> Transmitter>Eye Diagram** to display the Eye Diagram screen.

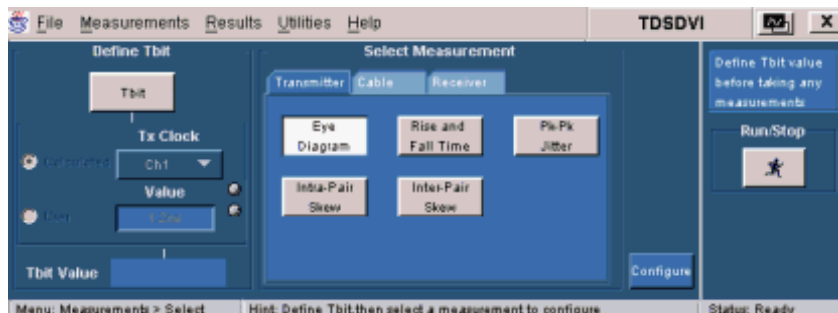
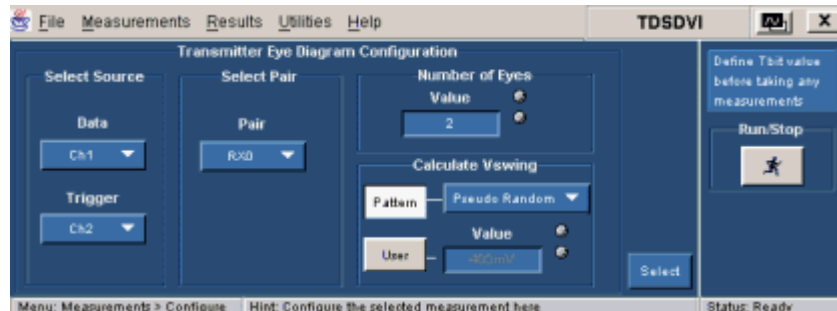



Figure 3-91: Eye Diagram pane

2. You have to define Tbit:
 - If you have not calculated the Tbit value
 - If you have changed the device, resolution, refresh rate or the blanking rate after calculating the Tbit
3. Select the **Configure** button to display the following screen.

**Figure 3-92: Eye Diagram configuration**

4. In the **Select Source** pane, select the data source channel from the **Data** drop-down list. This indicates which channel is connected in the TPA-P fixture with a differential probe. The available selections are: Ch1 to Ch4. The application requires a recovered clock as an external trigger source to the oscilloscope. Use the drop-down arrow in the Trigger field to set the trigger source channel. The available selections are: Ch1 to Ch4. You cannot set the same channel for Data and Trigger source.
5. Use the drop-down arrow in the **Pair** field to set the data pair. The available data pairs are:
 - RX0
 - RX1
 - RX2

***Note:** The data pair values appear only in the generated report. They are not used for any calculations.*

6. In the **Number of Eyes** field, use the GP knob or the calculator keypad  next to the Value field, to enter the minimum number of eyes to be considered to perform the test.
7. From the **Calculate Vswing** pane, you can calculate Vswing in two ways:
 - Select the **Pattern** button. Use the drop-down arrow to select the Pseudo Random or Half Clock to specify the pattern you want to use to calculate Vswing.

- If you know the Vswing value, select the **User** button. In the **Value** field, use the popup keyboard to enter your user-defined Vswing values. The default pattern is PRP
8. Press the **Run** button  to perform the test. The application displays the Confirm Tbit Value message box.
 9. If you have defined the Tbit value, the application displays the Eye Mask message box.
 10. If you have selected Half Clock Pattern, the application displays the next message box. Transmit the HCP from the DUT, connect the signals to the oscilloscope, and select **OK** in the message box below.

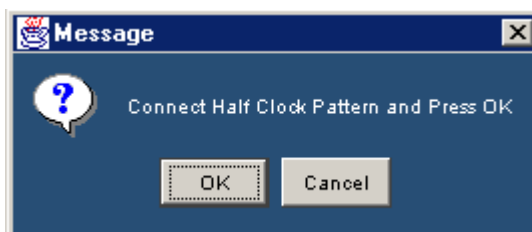

Figure 3-93: Half clock pattern message box

11. If you have selected PRP to calculate Vswing, the application displays the next message box. Transmit the PRP in the DUT, connect the signals to the oscilloscope and select **OK** in the message box below.

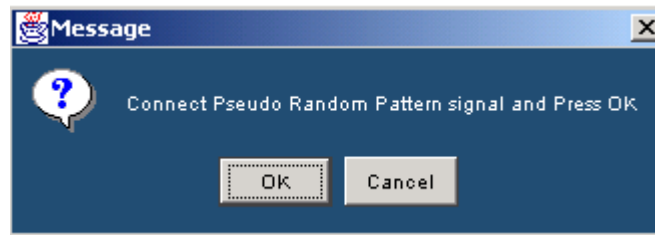

Figure 3-94: PRP message box

12. If you are using a TDS6000 series oscilloscopes, click here for information .

- If you have selected Half Clock Pattern in TDS6000 series Oscilloscopes, the application displays the next message box. (You can select the Stop button to stop the process and the Skip button to measure the Vswing with the current number of available acquisitions.)

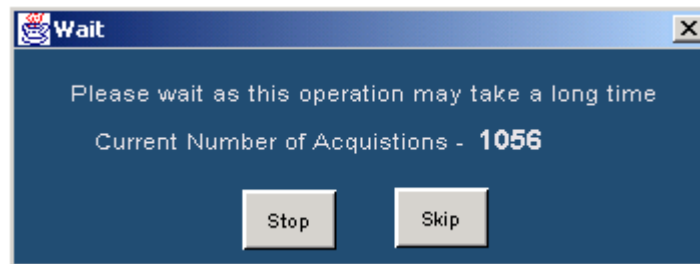

Figure 3-95: Wait message box

- If you have selected File> Preferences> Use Cursors for Eye, RT & FT Testing, the application enables the cursors on the oscilloscope to calculate the Vswing.
- After calculating Vswing using the Half Clock Pattern, the application displays the message box, "Connect the PRP pattern". Remove the TPA-P fixture from the DUT and connect the DVI monitor. Change the PRP pattern and remove the DVI monitor from the DUT. Connect the TPA-P fixture to the DUT and probe the selected data pair from the TPA-P and press OK to display the next message box.

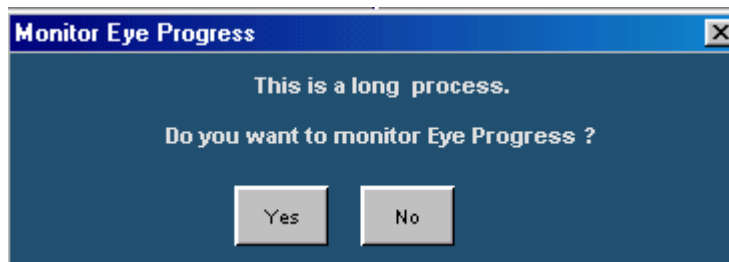

Figure 3-96: Monitor eye progress message box

- Select Yes to display the Eye Zoom screen. If you select No, the application continues to run the measurement.

(If you have selected **File> Preferences> Use Cursors for Eye, RT & FT Testing**, the application displays only the **Wait** message box.)

13. If you have selected **File> Preferences> General> Use cursors for Eye, RT & FT Testing**, Click here for information on what the application does to calculate Vswing and the Worst eye opening. The application tests the signal with the transmitter eye mask and displays the results.

Viewing Results: Eye Diagram

Follow these steps to view Eye Diagram results:

1. Select **Results> Result Detail** to display the detailed results for the Transmitter Eye Measurement.

You can also use the:

- **Compare Result** button to compare results
- **Eye Zoom** button to view the zoomed eye
- **Generate Report** button to generate reports

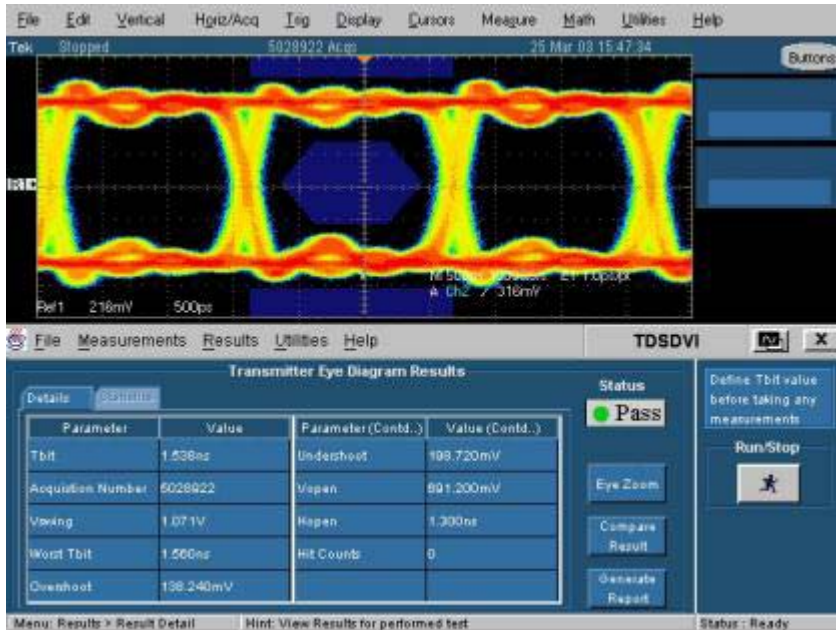

Figure 3-97: Eye Diagram results

Table 3-17 lists the eye diagram result options and their descriptions.

Table 3-17: Results: Eye diagram options and their descriptions

Results	Description
Parameter	Displays the calculated parameters for the measurement such as, Tbit, Acquisition Number, Vswing, Worst Tbit, Overshoot, Undershoot, Vopen, Hopen and the Hit Counts
Value	Displays the values of: Tbit used for calculating the coordinates of the eye mask Calculated Worst Tbit The number of acquisitions to create the eye diagram Calculated Vswing in volts Calculated Overshoot, Undershoot of the eye diagram Vopen in volts and Hopen in seconds The number of Hit counts on the eye mask
Status	Displays the result status: Pass or Fail.

Generating Reports

*Note: Select **File> Export Setup> Images> Data Format** from the oscilloscope menu. Set the data format option to .jpg before generating a report. The report format does not support any other image file. Before you run the measurement, select **Automatic IDs & Report Names** to automatically generate a report.*

Follow these steps to generate a report for all the measurements:

1. Select **Reports> Report Generation** to display the following screen.

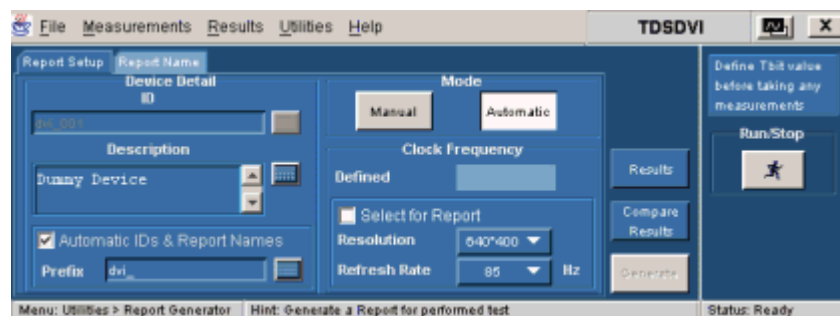

Figure 3-98: Generate report, report setup tab

2. In the **Report Setup** tab, use the virtual keypad to enter the device **ID**.
3. In the **Description** field, use the virtual keypad to enter the device description.
4. If you have not yet run the measurement, and if you want the application to display the device ID and specify the report names automatically, select the **Automatic IDs & Report Names** checkbox. The ID field is disabled if you

select this option. The ID, File Name fields, and Generate button are disabled if this option is selected.

5. In the **Prefix** field, use the virtual keypad to enter the device prefix.
6. Select the **Mode** of generating the report: **Manual or Automatic**. If you select the Manual mode, the Prefix field is disabled. If you select the Automatic mode, Device ID field is disabled.
7. The **Defined** field displays the predefined clock frequency values automatically when you define and calculate Tbit.
8. Use the drop-down arrow in the **Resolution** and **Refresh Rate** field to set the values and calculate the clock frequency. The drop-down list provides the Resolution and Refresh Rate values according to the VESA standard. If you select the **Select for Report** check box, the application displays the resolution and refresh rate in the generated report.
9. If you do not want to specify the report details, select the **Generate** button. You can do this only if you have selected the Manual mode of generating a report. If you want to specify the report details, perform the following steps:

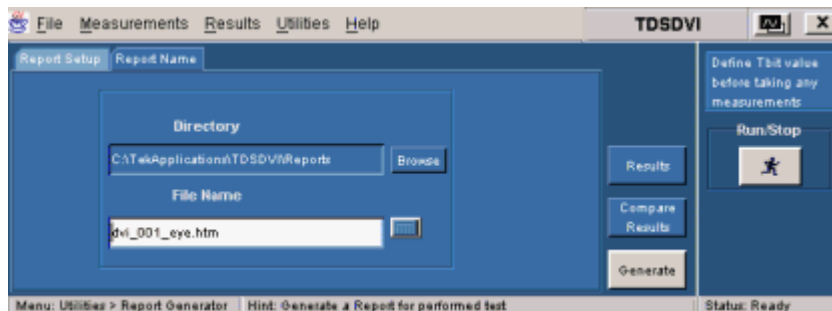

Figure 3-99: Generate Report, report name tab

1. In the **Report Name** tab, select the **Browse** button in the **Directory** field to browse to the directory location.
2. In the **File Name** field, use the virtual keypad to enter the file name.
3. You can use the Results option to view the results and the Compare Results option to compare results of two different devices.
4. Select the **Generate** button to generate report an HTML report. Given below is a sample Eye Diagram report.

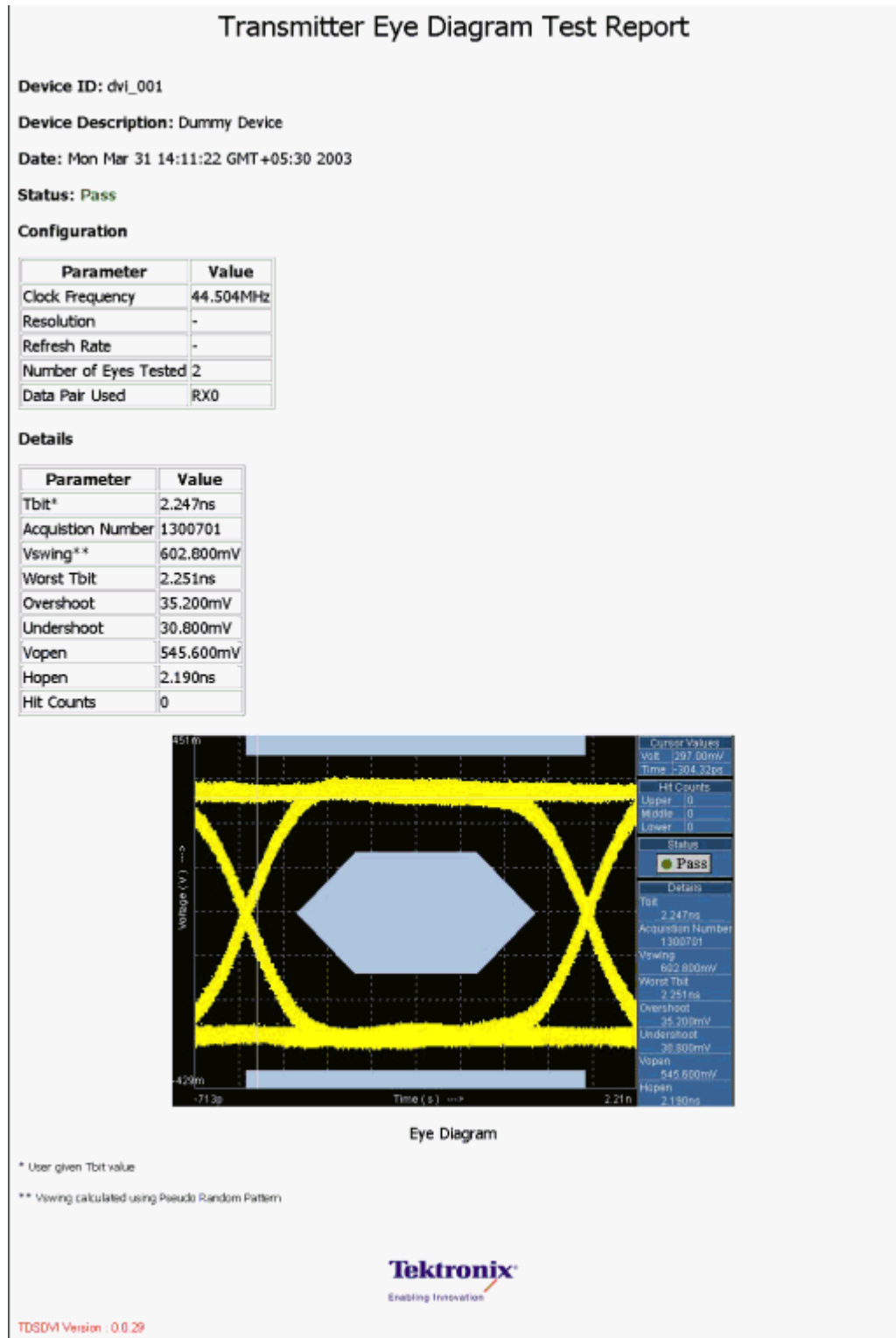

Figure 3-100: Eye Diagram report

How to Test Transmitter for Rise Time and Fall Time

Selecting and Configuring Measurements: Rise and Fall Time

Follow these steps to select and configure Rise and Fall Time:

Note: Refer page 137 to set up the DUT before using the application.

1. Select **Measurements > Select > Transmitter > Rise and Fall Time** to display the following screen.

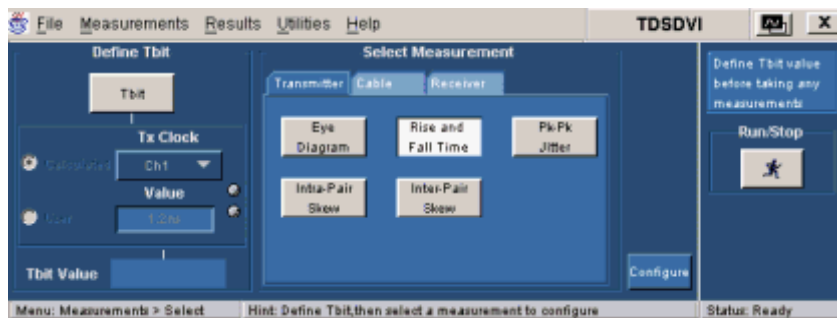

Figure 3-101: Rise and Fall Time pane

2. You have to define Tbit:
 - If you have not calculated the Tbit value
 - If you have changed the device, resolution, refresh rate or the blanking rate after calculating the Tbit
3. Select the **Configure** button to display the following screen.

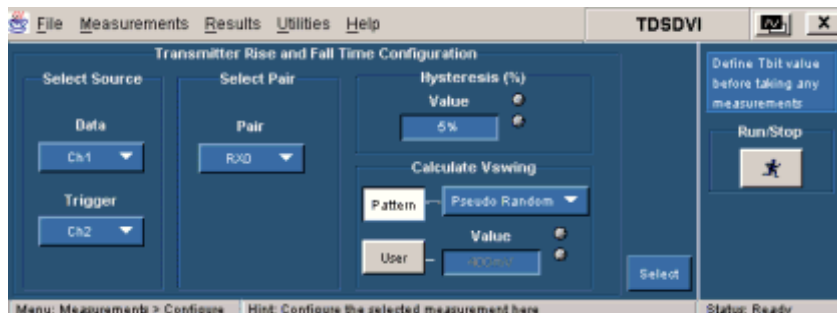



Figure 3-102: Rise and Fall Time configuration

4. Use the drop-down arrow in the Data field to select the data source channel. The available selections are: Ch1 to Ch4. The application requires a recovered clock as an external trigger source to the oscilloscope. Use the drop-down arrow in the **Trigger** field to set the trigger source channel.

5. Use the drop-down arrow in the **Select Pair** field to set the data pair. The available data pairs are:
 - RX0
 - RX1
 - RX2
6. In the Hysteresis field, use the GP knob or the calculator keypad  to enter the hysteresis percentage value. The hysteresis range is 2% to 10%.
7. From the **Calculate Vswing** pane, you can calculate Vswing in two ways:
 - Select the Pattern button. Use the drop-down arrow to select the Pseudo Random or Half Clock to specify the pattern you want to use to calculate Vswing.
 - If you know the Vswing value, select the **User** button. In the **Value** field, use the calculator keypad  to enter the user defined Vswing values. The default pattern is PRP.
8. Press the **Run** button to perform the test. The application displays the Confirm Tbit Value message box.
9. If you have selected Half Clock Pattern, the application displays the next message box. Generate the HCP in the DUT and select **OK** in the message box below. Refer page 182 on how to generate the HCP in the DUT.

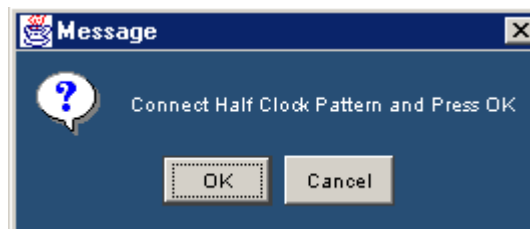

Figure 3-103: HCP message box

10. If you have selected PRP to calculate the Vswing, the application displays the next message box. Generate the PRP in the DUT and select **OK** in the message box below. Refer page 182 on how to generate the PRP in the DUT.



Figure 3-104: PRP message box

11. If you are using a TDS6604, TDS6404, TDS6604B, or TDS6804B oscilloscope, click here for information.
 - Select the **Stop** button to stop the process. If you select the **Skip** button, the application measures the Vswing with the current number of acquisitions.

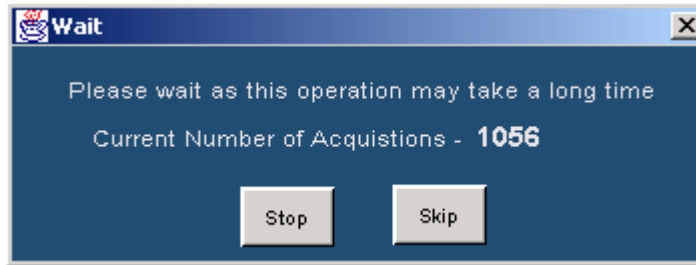

Figure 3-105: Wait message box

12. If you have selected **File> Preferences> General> Use cursors for Eye, RT & FT Testing**, refer page 182 for information on what the application does to calculate Vswing. The application calculates the Rise and Fall time and displays the results.

Viewing Results: Rise and Fall Time

Follow these steps to view Rise and Fall Time results:

1. Select **Results> Result Detail** to display the detailed and statistical results for the Transmitter **Rise and Fall Time** Measurement.

You can also use:

- **Compare Result** button to compare results
- **Generate Report** button to generate reports

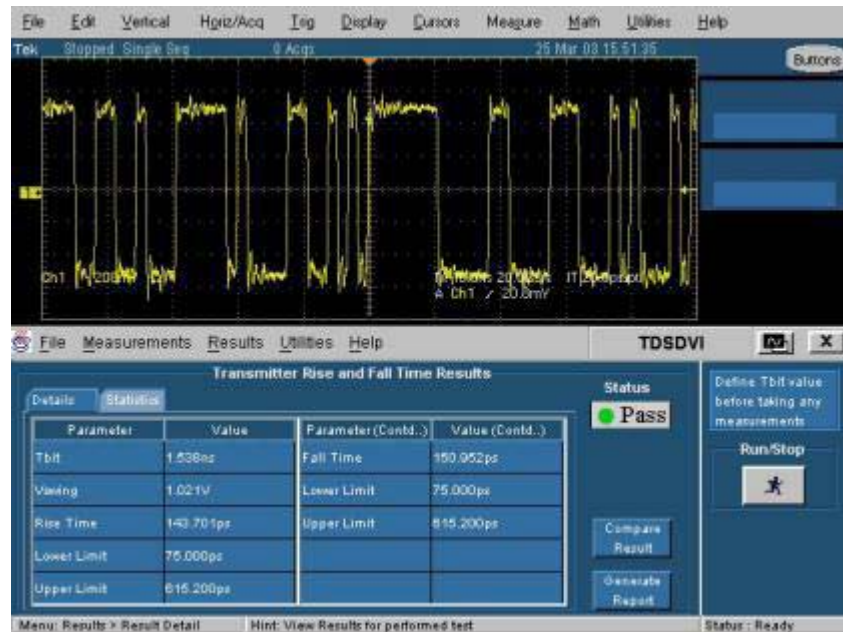

Figure 3-106: Rise and Fall Time results-Details

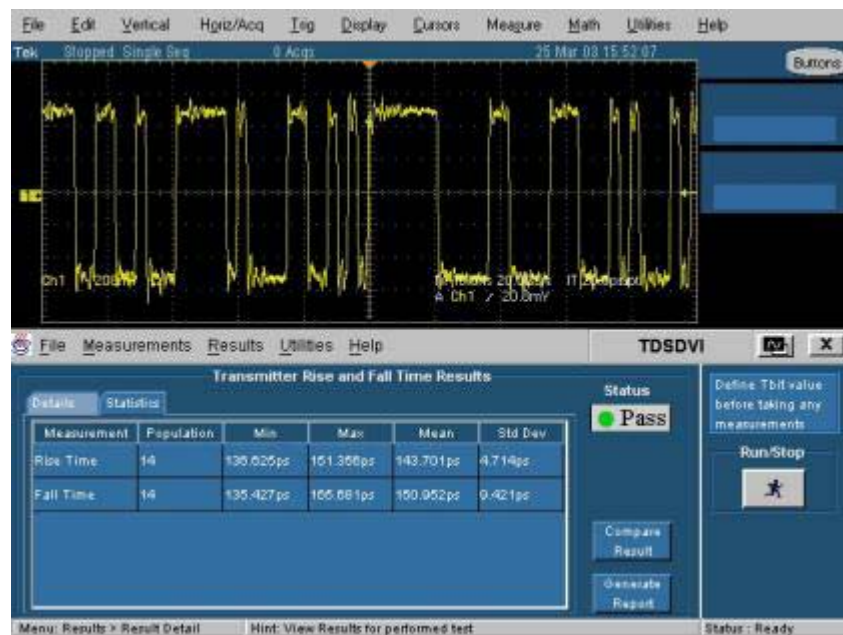

Figure 3-107: Rise and Fall Time results-Statistics

Table 3-18 lists the rise and fall time result options and their descriptions.

Table 3-18: Results: Rise and Fall time options and their descriptions

Results	Description
Details tab	
Parameter	Displays the calculated parameters for the measurement such as, Tbit, Vswing, Worst Tbit, Lower Limit and Upper Limits for Rise Time and Fall Time.
Value	Displays the values of: <ul style="list-style-type: none"> ▪ Tbit used for calculating the limits of Rise and Fall Time ▪ Calculated Vswing in volts ▪ Calculated Overshoot, Undershoot of the eye diagram ▪ Vopen in millivolts and Hopen in seconds ▪ The measured Rise time and Fall time value in seconds ▪ The lower limit for Rise time and Fall time. Values below this limit indicate a Fail ▪ The upper limit for Rise time and Fall time. Values above this limit indicate a Fail
Statistics tab	
Measurement	Displays the selected measurement.
Population	The number of edges calculated in the acquired waveform.
Min	The minimum Rise and Fall Time value in the acquired waveform.
Max	The maximum Rise and Fall Time value in the acquired waveform.
Mean	The average of all the calculated Rise Time values.
Std Dev	The standard deviation of all the calculated Rise and Fall time values.
Status	Displays the result status:Pass or Fail. This is common to both the Details and Statistics tab.

Generating Reports Follow these steps to generate a report for all the measurements:

***Note:** Select **File> Export Setup> Images> Data Format** from the oscilloscope menu. Set the data format option to .jpg before generating a report. The report format does not support any other image file. Before you run the measurement, select **Automatic IDs & Report Names** to automatically generate a report.*

1. Select **Reports> Report Generation** to display the following screen.

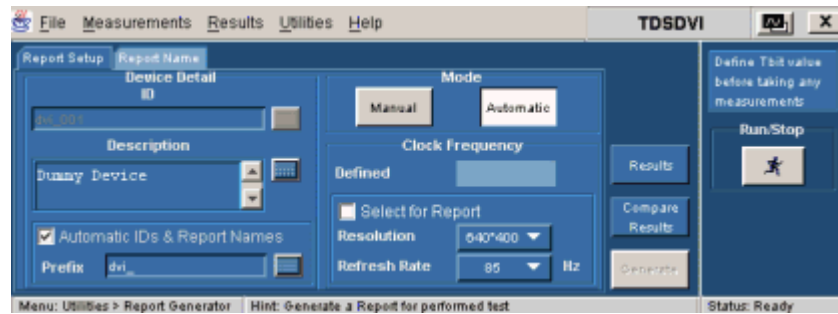

Figure 3-108: Generate Report, report setup

2. In the **Report Setup** tab, use the virtual keypad to enter the device **ID**.
3. In the **Description** field, use the virtual keypad to enter the device description.
4. If you have not yet run the measurement, and if you want the application to display the device ID and specify the report names automatically, select the Automatic IDs & Report Names checkbox. The ID field is disabled if you select this option. The ID, File Name fields, and Generate button are disabled if this option is selected.
5. In the **Prefix** field, use the virtual keypad to enter the device prefix.
6. Select the **Mode** of generating the report: **Manual or Automatic**. If you select the Manual mode, the Prefix field is disabled. If you select the Automatic mode, Device ID field is disabled.
7. The **Defined** field displays the predefined clock frequency values automatically when you define and calculate Tbit.
8. Use the drop-down arrow in the **Resolution** and **Refresh Rate** field to set the values and calculate the clock frequency. The drop-down list provides the Resolution and Refresh Rate values according to the VESA standard. If you select the **Select for Report** check box, the application displays the resolution and refresh rate in the generated report.
9. If you do not want to specify the report details, select the **Generate** button. You can do this only if you have selected the Manual mode of generating a report. If you want to specify the report details, perform the following steps:

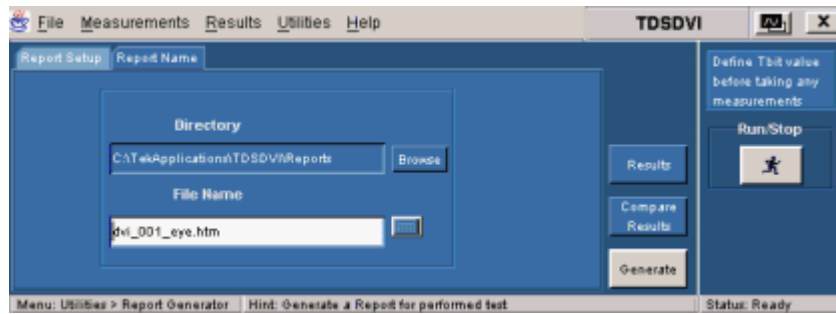

Figure 3-109: Generate Report, report name

1. In the **Report Name** tab, select the **Browse** button in the **Directory** field to browse to the directory location.
2. In the **File Name** field, use the virtual keypad to enter the file name.
3. You can use the **Results** option to view the results and the **Compare Results** option to compare results of two different devices.
4. Select the **Generate** button to generate report an HTML report.

How to Test Transmitter for Pk-Pk Jitter

Selecting and Configuring
Measurements:Pk-Pk Jitter

Measurement> Select> Transmitter> Pk-Pk Jitter
Measurement> Select> Cable> Pk-Pk Jitter

Note: Refer page 140 to setup the DUT before using the application for Transmitter Pk-Pk Jitter.

Note: Refer page 149 to set up the DUT before using the application for Cable Pk-Pk Jitter

Note: To get appropriate results in Pk-Pk Jitter measurements, from the oscilloscope menu bar, select Measure->**Waveform Histograms->Adjust Histogram Box Limits.**

Follow these steps to select and configure Pk-Pk Jitter:

1. Select **Measurements> Select> Transmitter/Cable> Pk-Pk Jitter** to display the screen.

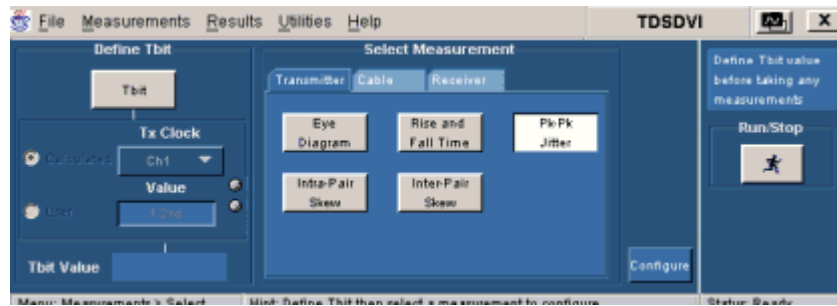

Figure 3-110: Transmitter Pk-Pk Jitter pane

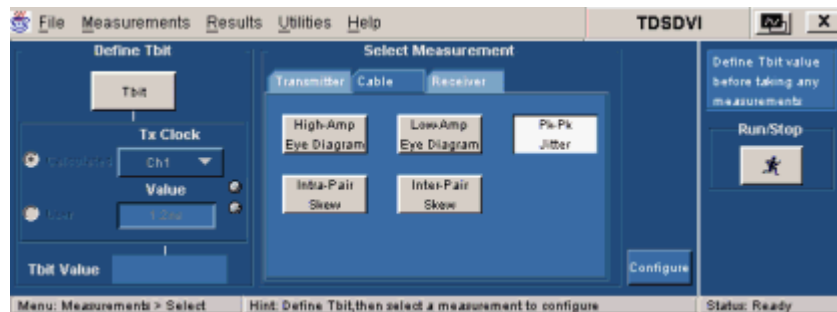

Figure 3-111: Cable Pk-Pk Jitter pane

2. You have to define Tbit:
 - If you have not calculated the Tbit value
 - If you have changed the device, resolution, refresh rate or the blanking rate after calculating the Tbit
3. Select the **Configure** button to display the following screen:

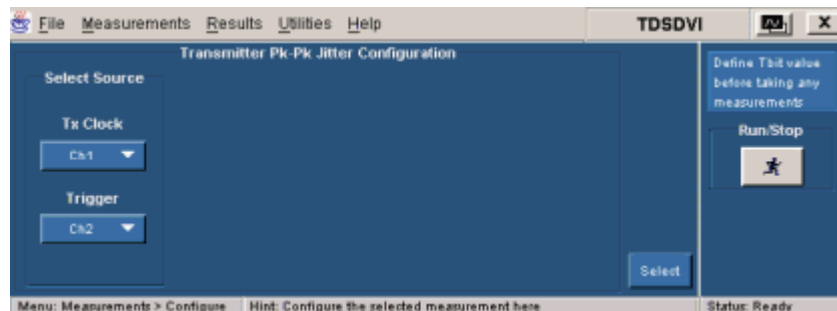

Figure 3-112: Transmitter Pk-Pk Jitter configuration

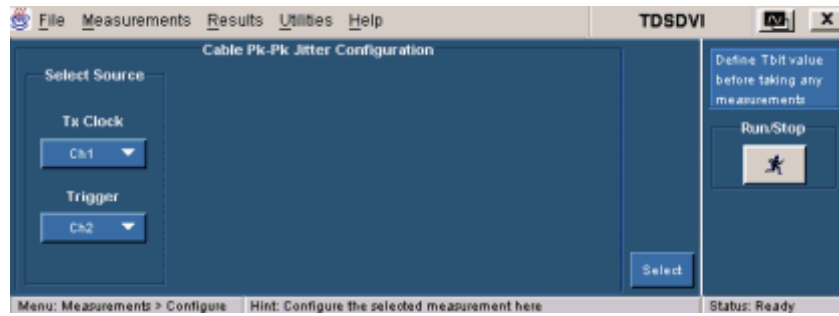



Figure 3-113: Cable Pk-Pk Jitter configuration

4. Select the transmitted differential clock source from the **Tx Clock** drop-down list. The available selections are: Ch1 to Ch4. The application requires a CRU (Clock Recovery Unit) to trigger the oscilloscope. Set the trigger source channel from the **Trigger** drop-down list. Data and Trigger source are mutually exclusive.
5. Press the **Run** button  to perform the test. The application displays the Confirm Tbit Value message box.
6. Confirm the Tbit value to display the next message box. Connect the clock signals and press **OK**.

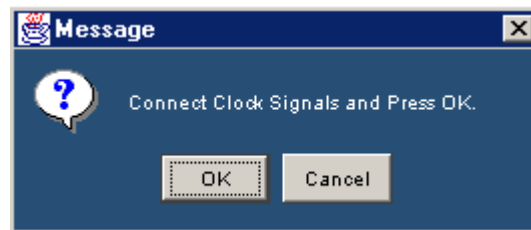

Figure 3-114: Clock signals message box

The application calculates the Pk-PK Jitter and displays the result: Pass or Fail.

***Note:** For more in-depth analysis on Jitter, use the TDSJIT3 Package.*

If the signal is unstable, the application cannot place the histogram at the second rising edge of the clock signal, then the application displays the following message box.

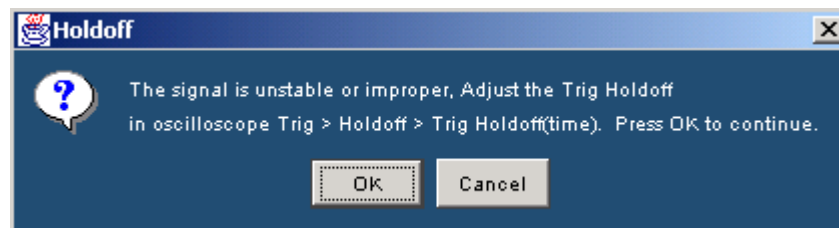

Figure 3-115: Holdoff message box

To adjust the Trigger Holdoff time,

1. Select **Trig > Holdoff** from the oscilloscope interface as shown in Figure: 3-115.
2. Use the GP knob on the oscilloscope panel to adjust the trigger hold off time.
3. After stabilising the signal, press the **APP** button in the oscilloscope interface to display the application.
4. Press **OK** in the Figure 3-115 Holdoff message box to continue the peak to peak jitter measurement and Cancel to stop running the measurement.



Figure 3-116: Oscilloscope interface

Viewing Results: Pk-Pk Jitter

Follow these steps to view Pk-Pk Jitter results:

5. Select **Results > Result Detail** to display the detailed results for the Transmitter or Cable **Pk-Pk Jitter** Measurement.

You can also use:

- **Compare Result** button to compare results
- **Generate Report** button to generate reports

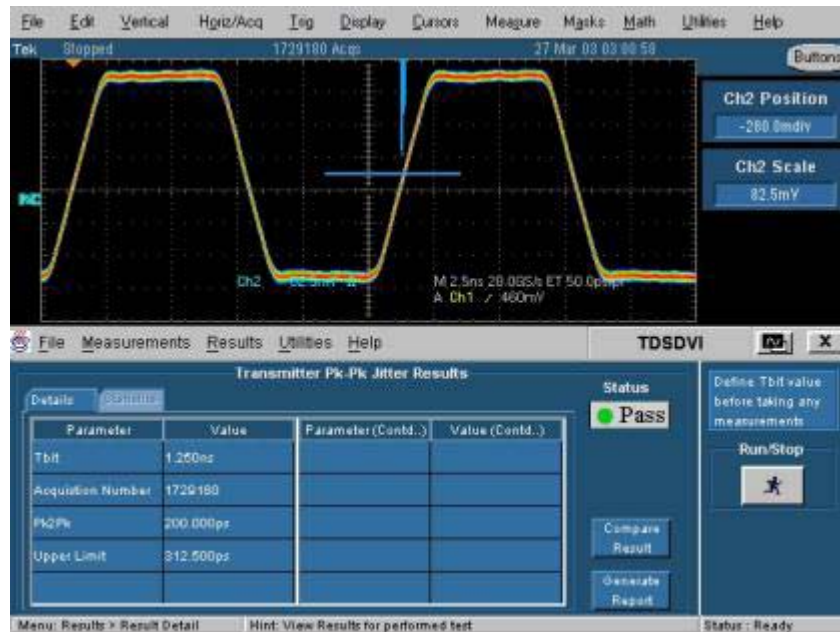

Figure 3-117: Pk-Pk Jitter results

Table 3-19 lists the pk-pk jitter result options and their descriptions.

Table 3-19: Results: Pk-Pk Jitter options and their descriptions

Results	Description
Parameter	Displays the calculated parameters for the measurement such as, Tbit, Acquisition Number, Pk to Pk jitter and its Upper Limit.
Value	Displays the values of: <ul style="list-style-type: none"> ▪ Tbit used for calculating the peak to peak jitter limits in seconds ▪ The number of acquisitions to create the histogram ▪ The measured peak to peak jitter values in seconds ▪ The maximum limit values for Jitter. The peak to peak jitter values above this limit indicate a Fail
Status	Displays the result status: Pass or Fail.

Generating Reports Follow these steps to generate a report for all the measurements:

*Note: Select **File> Export Setup> Images> Data Format** from the oscilloscope menu. Set the data format option to .jpg before generating a report. The report format does not support any other image file. Before you run the measurement, select **Automatic IDs & Report Names** to automatically generate a report.*

1. Select **Reports> Report Generation** to display the following screen.

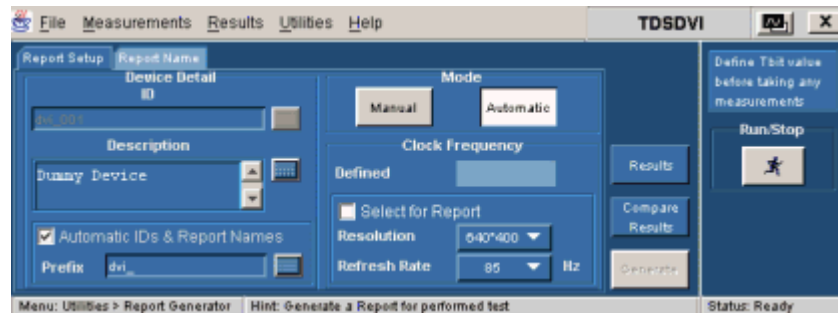

Figure 3-118: Generate report, report setup

2. In the **Report Setup** tab, use the virtual keypad to enter the device **ID**.
3. In the **Description** field, use the virtual keypad to enter the device description.
4. If you have not yet run the measurement, and if you want the application to display the device ID and specify the report names automatically, select the Automatic IDs & Report Names checkbox. The ID field is disabled if you select this option. The ID, File Name fields, and Generate button are disabled if this option is selected.
5. In the **Prefix** field, use the virtual keypad to enter the device prefix.
6. Select the **Mode** of generating the report: **Manual or Automatic**. If you select the Manual mode, the Prefix field is disabled. If you select the Automatic mode, Device ID field is disabled.
7. The **Defined** field displays the predefined clock frequency values automatically when you define and calculate Tbit.
8. Use the drop-down arrow in the **Resolution** and **Refresh Rate** field to set the values and calculate the clock frequency. The drop-down list provides the Resolution and Refresh Rate values according to the VESA standard. If you select the **Select for Report** check box, the application displays the resolution and refresh rate in the generated report.
9. If you do not want to specify the report details, select the **Generate** button. You can do this only if you have selected the Manual mode of generating a report. If you want to specify the report details, perform the following steps:

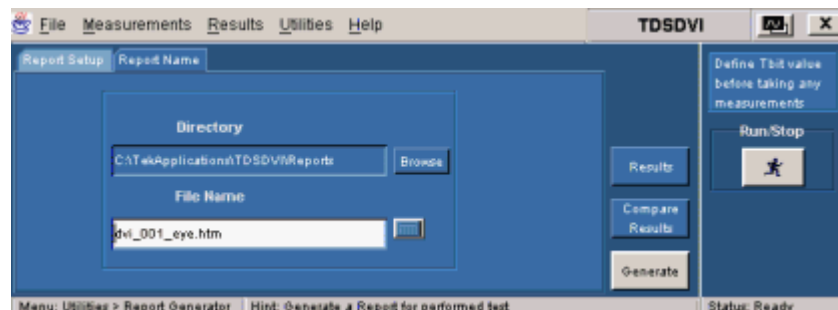

Figure 3-119: Generate report, report name

1. In the **Report Name** tab, select the **Browse** button in the **Directory** field to browse to the directory location.
2. In the **File Name** field, use the virtual keypad to enter the file name.
3. You can use the Results option to view the results and the Compare Results option to compare results of two different devices.
4. Select the **Generate** button to generate report an HTML report

How to Test Transmitter for Intra-Pair Skew

Selecting and Configuring Measurements: Intra-Pair Skew

Measurement> Select> Transmitter>Intra-Pair Skew
 Measurement> Select> Cable> Intra-Pair Skew

Note: Refer page 143 to set up the DUT before using the application for Transmitter Intra-Pair Skew.

Note: Refer page150 to setup the DUT before using the application for Cable Intra-Pair Skew.

Follow these steps to select and configure Intra-Pair Skew:

1. Select **Measurements> Select> Transmitter/Cable> Intra-Pair Skew** to display the following screen.

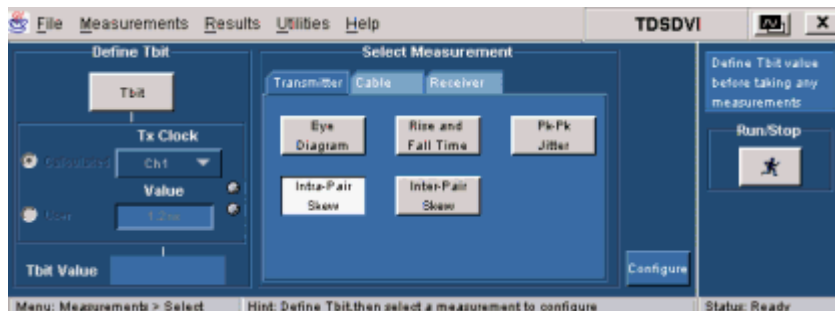

Figure 3-120: Transmitter Intra-Pair Skew pane

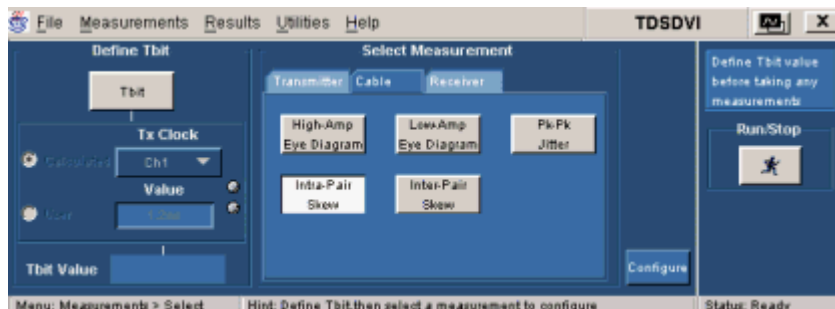

Figure 3-121: Cable Intra-Pair Skew pane

2. You have to define Tbit:
 - If you have not calculated the Tbit value
 - If you have changed the device, resolution, refresh rate or the blanking rate after calculating the Tbit
3. Select the **Configure** button to display the following screen.

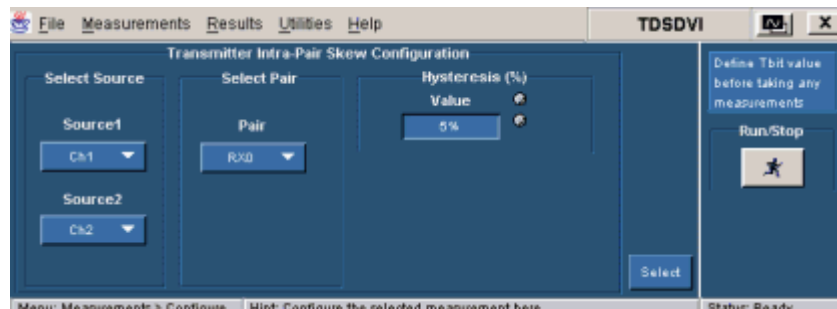

Figure 3-122: Transmitter Intra-Pair Skew configuration

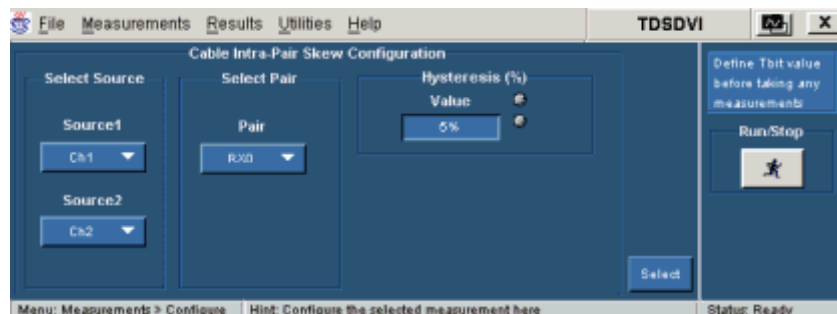



Figure 3-123: Cable Intra-Pair Skew configuration

4. Set the data line (+ or -) of a data pair in the **Source** drop-down list. The available selections are: Ch1 to Ch4. The Source channels are mutually exclusive. Use two single-ended probes to connect the data pair (for example: Rx0+ or Rx0-) to Source1 and Source2.
5. Set the data pair in the **Pair** drop down list. The available selections are:
 - RX0
 - RX1
 - RX2
6. In the **Hysteresis** field, use the calculator keypad or the GP knob to enter the hysteresis percentage value. The range for the hysteresis is 2% to 10%.

7. Press the **Run** button  to perform the test. The application displays the Confirm Tbit Value message box.
8. Select **Yes** to display the next message box. Connect the data signals and press **Ok**.

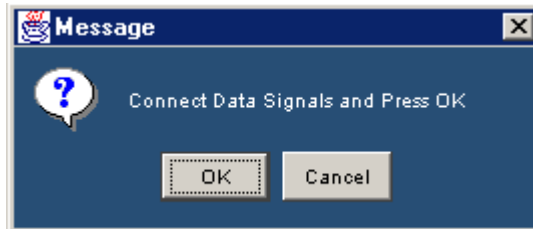

Figure 3-124: Data signals message box

The application calculates the Intra-Pair Skew and displays the result: Pass or Fail.

Viewing Results: Intra-Pair Skew

Follow these steps to view Intra-Pair Skew results:

1. Select **Results> Result Detail** to display the detailed and statistical results for the Transmitter or Cable **Intra-Pair Skew** Measurement.

You can also use:

- **Compare Result** button to compare results
- **Generate Report** button to generate reports



Figure 3-125: Intra-Pair Skew results

Table 3-20 lists the intra-pair skew result options and their descriptions.

Table 3-20: Results: Intra-Pair Skew options and their descriptions

Results	Description
Details tab	
Parameter	Displays the calculated parameters for the measurement such as, Tbit, Skew and its Upper Limit.
Value	Displays the values of: <ul style="list-style-type: none"> ▪ Tbit used for calculating the intra-pair skew limits ▪ The measured skew ▪ The maximum limit for intra-pair skew. Values above this limit indicate a Fail
Statistics tab	
Measurement	Displays the selected measurement.
Population	The number of edges calculated in the acquired waveform.
Min	The minimum intra-pair skew value in the acquired waveform.
Max	The maximum intra-pair skew value in the acquired waveform.
Mean	The average of all the calculated intra-pair skew values.
Std Dev	The standard deviation of all the calculated intra-pair skew values.
Status	Displays the result status: Pass or Fail. This is common for the Details and the Statistics tab.

Generating Reports Follow these steps to generate a report for all the measurements:

*Note: Select **File> Export Setup> Images> Data Format** from the oscilloscope menu. Set the data format option to .jpg before generating a report. The report format does not support any other image file. Before you run the measurement, select **Automatic IDs & Report Names** to automatically generate a report.*

1. Select **Reports> Report Generation** to display the following screen.

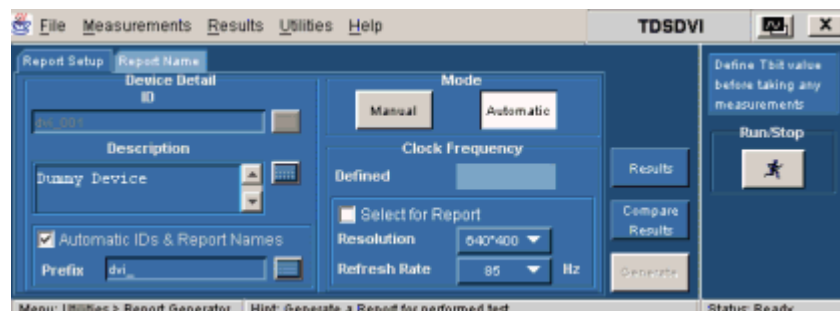

Figure 3-126: Generate reports, report setup

2. In the **Report Setup** tab, use the virtual keypad to enter the device **ID**.
3. In the **Description** field, use the virtual keypad to enter the device description.
4. If you have not yet run the measurement, and if you want the application to display the device ID and specify the report names automatically, select the Automatic IDs & Report Names checkbox. The ID field is disabled if you select this option. The ID, File Name fields, and Generate button are disabled if this option is selected.
5. In the **Prefix** field, use the virtual keypad to enter the device prefix.
6. Select the **Mode** of generating the report: **Manual or Automatic**. If you select the Manual mode, the Prefix field is disabled. If you select the Automatic mode, Device ID field is disabled.
7. The **Defined** field displays the predefined clock frequency values automatically when you define and calculate Tbit.
8. Use the drop-down arrow in the **Resolution** and **Refresh Rate** field to set the values and calculate the clock frequency. The drop-down list provides the Resolution and Refresh Rate values according to the VESA standard. If you select the **Select for Report** check box, the application displays the resolution and refresh rate in the generated report.
9. If you do not want to specify the report details, select the **Generate** button. You can do this only if you have selected the Manual mode of generating a report. If you want to specify the report details, perform the following steps:

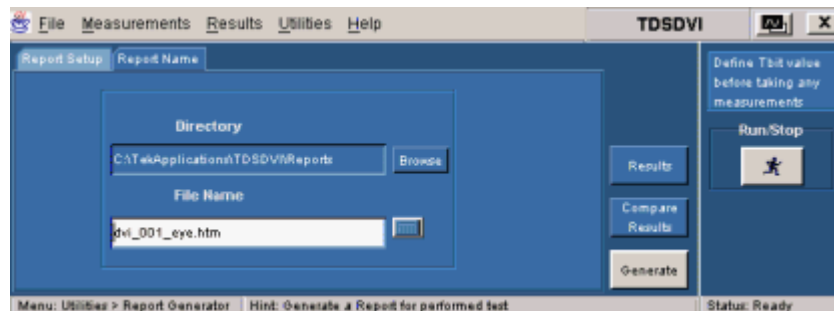

Figure 3-127: Generate reports, report name

1. In the **Report Name** tab, select the **Browse** button in the **Directory** field to browse to the directory location.
2. In the **File Name** field, use the virtual keypad to enter the file name.
3. You can use the Results option to view the results and the Compare Results option to compare results of two different devices.
4. Select the **Generate** button to generate report an HTML report.

How to Test Transmitter for Inter-Pair Skew

Selecting and Configuring Measurements: Inter Pair Skew

Follow these steps to select and configure Inter-Pair Skew:

Note: Refer page146 to set up the DUT before using the application.

1. Select **Measurements> Select> Transmitter> Inter-Pair Skew** to display the following screen.

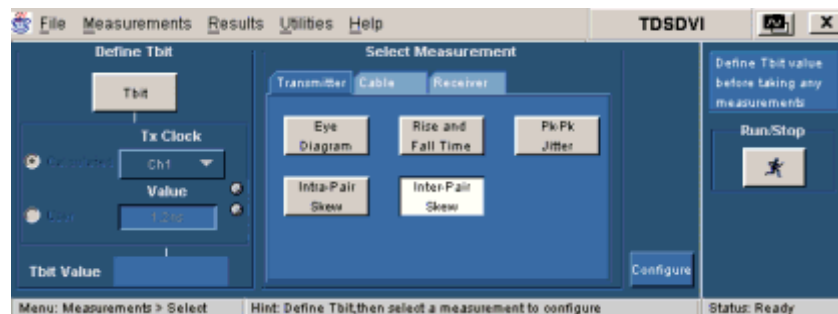

Figure 3-128: Inter-Pair Skew pane

2. You have to define Tbit:
 - If you have not calculated the Tbit value
 - If you have changed the device, resolution, refresh rate or the blanking rate after calculating the Tbit
3. Select the **Configure** button to display the following screen:

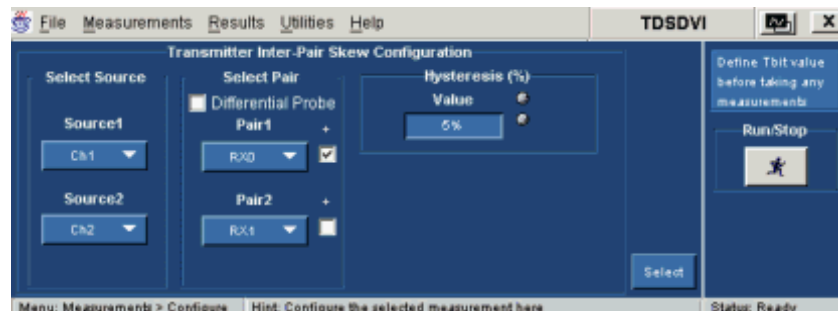



Figure 3-129: Inter-Pair Skew configuration

4. Set the data line (+ or -) of the data pair in the **Source1 and Source2** drop-down list. The available selections are: Ch1 to Ch4. The Source channels are mutually exclusive. Use two single-ended probes to connect the data pair (for example: Rx0+ or Rx1-) to Source1 and Source2. If you have selected Inter-Pair Skew option, use the drop-down arrow in the **Pair1 and Pair2** field to set the data pairs. If you select the Differential Probe check box, the

positive check boxes next to the pair fields are disabled. If you use a differential probe, the application calculates the time delay between two data pairs. If you use a single-ended probe, the application calculates the skew between the data lines. The available selections are:

- RX0
- RX1
- RX2

If the data pairs are positive, select the check box next to the **Pair** fields. You cannot select the same data pair in the **Pair1** and **Pair2** fields irrespective of the selected polarity (+ or -). If you select the Differential Probe check box, the positive check boxes next to the pair fields are disabled and the application calculates the time delay between the two data pairs.

5. Press the **Run** button . The application displays the Confirm Tbit Value message box.
6. Select **Yes** to display the next message box. Connect the data signals and press **Ok**.

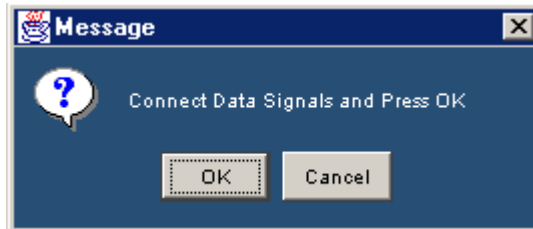

Figure 3-130: Data signals message box

The application calculates the Inter-Pair Skew and displays the result: Pass or Fail.

Viewing Results: Inter-Pair Skew

Follow these steps to view Inter-Pair Skew results.

1. Select **Results> Result Detail** to display the detailed results for the Transmitter **Inter-Pair Skew** Measurement.

You can also use the:

- **Compare Result** button to compare results
- **Generate Report** button to generate reports



Figure 3-131: Inter-Pair Skew results

Table 3-21 lists the inter-pair skew result options and their descriptions.

Table 3-21: Results: Inter-Pair Skew options and their descriptions

Results	Description
Details tab	
Parameter	Displays the calculated parameters for the measurement such as, Tbit, Skew and its Upper Limit.
Value	Displays the values of: Tbit used for calculating inter-pair skew limits in seconds The measured skew in seconds The maximum limit for inter-pair skew. Values above this limit indicate a Fail
Statistics tab	
Measurement	Displays the selected measurement.
Population	The number of edges calculated in the acquired waveform.
Min	The minimum inter-pair skew value in the acquired waveform.
Max	The maximum inter-pair skew value in the acquired waveform.
Mean	The average of all the calculated inter-pair skew values.
Std Dev	The standard deviation of all the calculated inter-pair skew values.
Status	Displays the result status: Pass or Fail. This is common for the Details and the Statistics tab.

Generating Reports Follow these steps to generate a report for all the measurements:

*Note: Select File> Export Setup> Images> Data Format from the oscilloscope menu. Set the data format option to .jpg before generating a report. The report format does not support any other image file. Before you run the measurement, select **Automatic IDs & Report Names** to automatically generate a report.*

1. Select **Reports> Report Generation** to display the following screen.

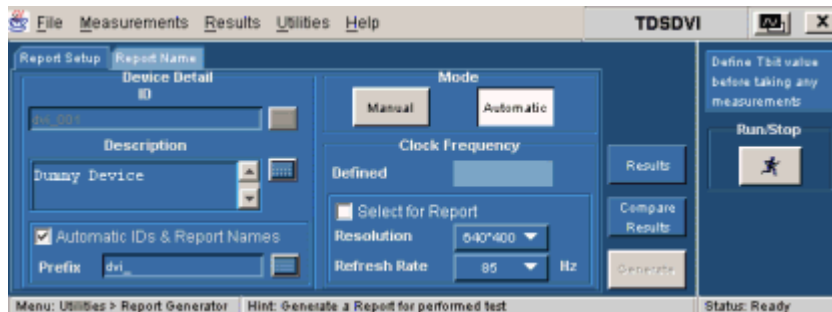

Figure 3-132: Generate report, report setup

2. In the **Report Setup** tab, use the virtual keypad to enter the device **ID**.
3. In the **Description** field, use the virtual keypad to enter the device description.
4. If you have not yet run the measurement, and if you want the application to display the device ID and specify the report names automatically, select the **Automatic IDs & Report Names** checkbox. The ID field is disabled if you select this option. The ID, File Name fields, and Generate button are disabled if this option is selected.
5. In the **Prefix** field, use the virtual keypad to enter the device prefix.
6. Select the **Mode** of generating the report: **Manual or Automatic**. If you select the Manual mode, the Prefix field is disabled. If you select the Automatic mode, Device ID field is disabled.
7. The **Defined** field displays the predefined clock frequency values automatically when you define and calculate Tbit.
8. Use the drop-down arrow in the **Resolution** and **Refresh Rate** field to set the values and calculate the clock frequency. The drop-down list provides the Resolution and Refresh Rate values according to the VESA standard. If you select the **Select for Report** check box, the application displays the resolution and refresh rate in the generated report.
9. If you do not want to specify the report details, select the **Generate** button. You can do this only if you have selected the Manual mode of generating a report. If you want to specify the report details, perform the following steps:

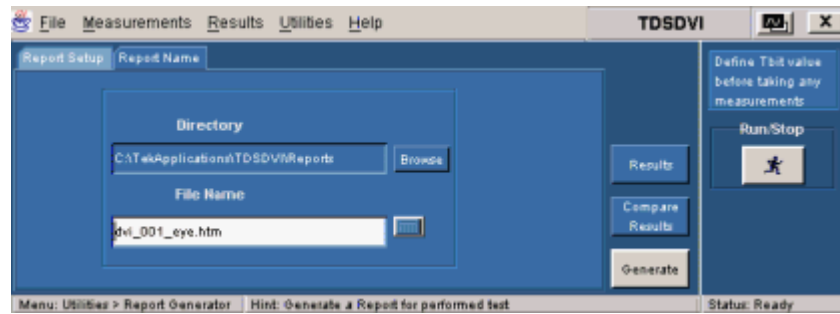

Figure 3-133: Generate report, report name

1. In the **Report Name** tab, select the **Browse** button in the **Directory** field to browse to the directory location.
2. In the **File Name** field, use the virtual keypad to enter the file name.
3. You can use the **Results** option to view the results and the **Compare Results** option to compare results of two different devices.
4. Select the **Generate** button to generate report an HTML report.

How to Test Cable for Hi-Amplitude/Low-Amplitude Eye Measurement

Select and Configure Measurements: High-Amplitude/Low-Amplitude Eye Diagram

Measurement> Select> Cable> High-Amplitude/Low-Amplitude Eye Diagram

Follow these steps to select and configure High-Amplitude/Low-Amplitude Eye Diagram:

Note: Refer page155 to set up the DUT before using the application.

1. Select the **Measurements> Select> Cable** tab to display the following screen. Select the High-Amplitude/Low-Amplitude Eye Diagram option.

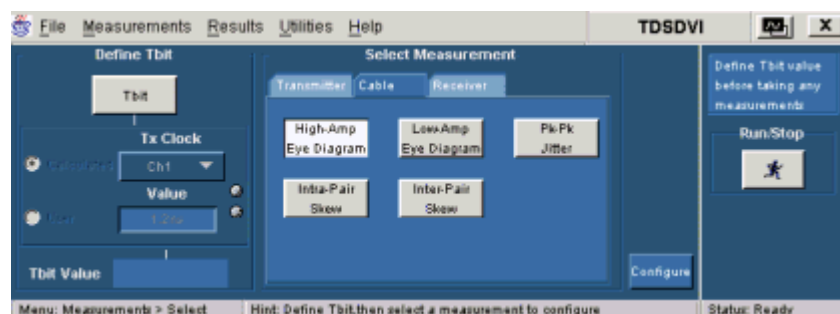

Figure 3-134: High-Amplitude Eye Diagram

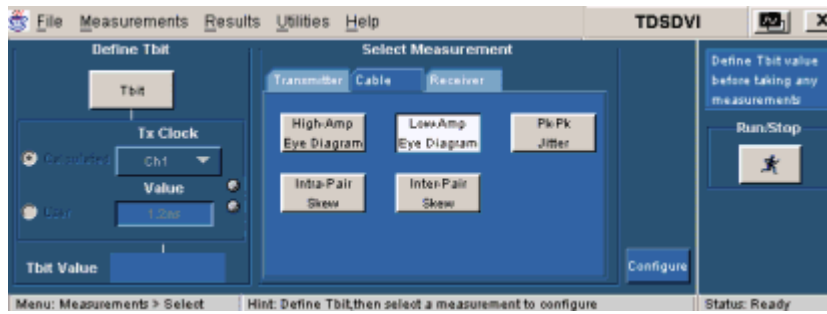

Figure 3-135: Low-Amplitude Eye Diagram

2. You have to define Tbit:
 - If you have not calculated the Tbit value
 - If you have changed the device, resolution, refresh rate or the blanking rate after calculating the Tbit
3. Select the **Configure** button to display the following screen.

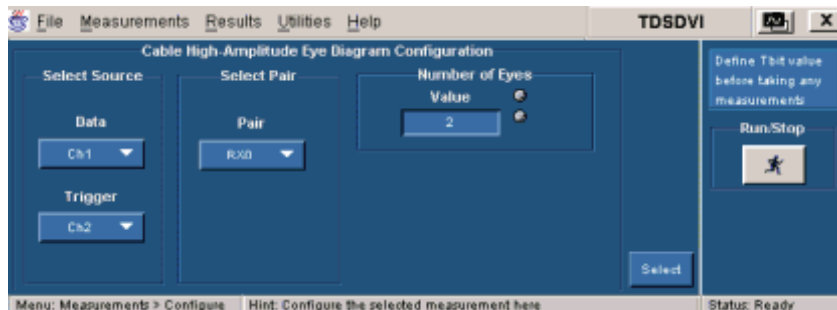

Figure 3-136: High-Amplitude Eye Diagram configuration

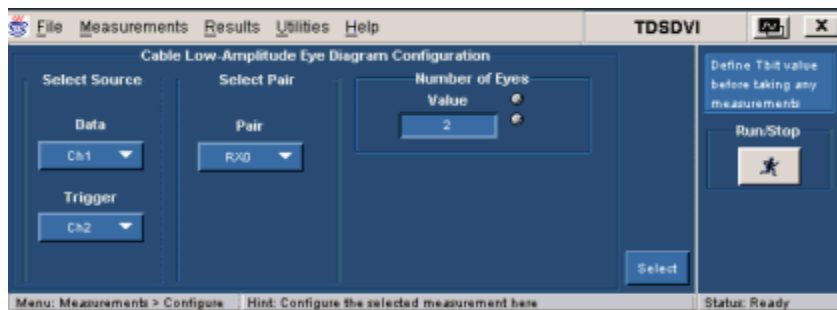



Figure 3-137: Low-Amplitude Eye Diagram configuration

4. In the **Select Source** area, from the **Data** drop-down list, indicate which channel is connected to the TPA-P fixture (at TP2) with a differential probe. See page 184 to know about the TPA-P fixture at TP2 connections. The available selections are: Ch1 to Ch4. The application requires a recovered clock as an external trigger source to the oscilloscope. Set the trigger source in the **Trigger** drop-down list. The available selections are: Ch1 to Ch4. Data and Trigger sources are mutually exclusive.

5. Use the drop-down arrow in the **Select Pair** field to set the data pair. The available data pairs are:
 - RX0
 - RX1
 - RX2

Note: The data pair values appear only in the generated report. They are not used for any calculations.

6. In the **Min number of Eyes** field, use the calculator keypad or the GP knob next to the **Value** field to enter the minimum number of eyes to be considered to place the mask.
7. Press the **Run** button  to perform the test. The application displays the Confirm Tbit Value message box
8. If the default option **File> Preferences> Advanced> Cable Eye Diagram Test Point> Test at TP2 and TP3** is used, the application does the following:
 - The application displays the next message box. Select the PRP pattern in the Equivalent Source Board (ESB), connect the signal from the TPA-P fixture and press **OK**. See page 184 to know about the TPA-P fixture connections.

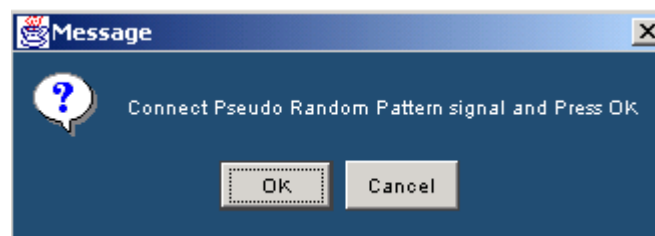

Figure 3-138: PRP message box

- The application tests the signal with Low/ High Amplitude eye mask.
- If the signal fails, the application displays the TP2 test status and does not allow you to proceed further till the signal passes the test. To make the signal pass the test, increase or decrease the Vswing accordingly and run the test again. See page 184 on how to increase or decrease the Vswing. If the signal passes, you can view the TP2 test results and the application displays the next message box.

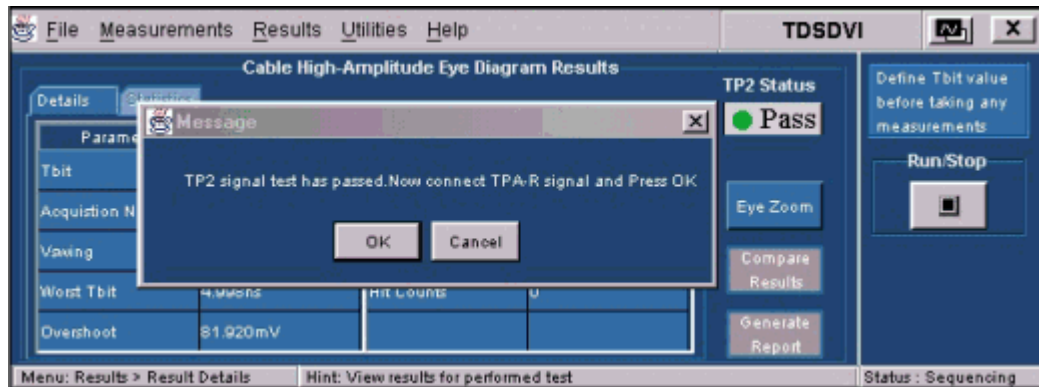

Figure 3-139: TPA-R message box

- Remove the TPA-P fixture at TP2 and connect the cable to the ESB board and the other end to TPA-R. See page 185 for information on the setup connections. Probe the correct data pairs from the TPA-R fixture and press **OK**.
- The application tests the signal with the cable limit eye mask.
- In the TDS66604, TDS6404, TDS6604B, and TDS6804B oscilloscopes, if you have selected Half Clock Pattern, the application displays the following message box. You can select the **Stop** button to stop the process.

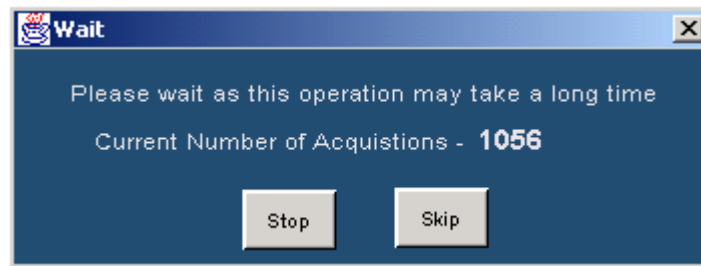

Figure 3-140: Wait message box

- The application completes the 10k acquisitions and displays the **Monitor Eye Progress** message box. Select **Yes** to display the Eye Zoom screen and **No** to stop running the measurement.

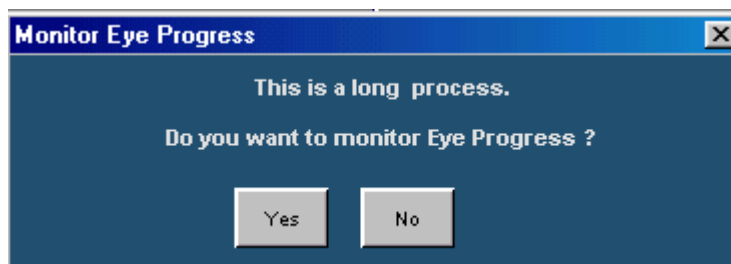

Figure 3-141: Monitor eye progress message box

For expert users:

If you have a standard signal that passes low or high amplitude mask, DVI application experts do not need to test cable at TP2 with low or high amplitude mask every time they run the cable measurement. For this purpose, we recommend you to select **File> Preferences> Advanced> Cable Eye Diagram Test Point** options.

- If you have selected **File> Preferences> Advanced> Cable Eye Diagram Test Point> Test at TP2**, the application performs the following sequence of steps.
 1. The application displays the message “Connect the PRP signal and press OK.”
 2. Select the PRP pattern in the Equivalent Source Board (ESB) and connect the signal from the TPA-P fixture and press OK.

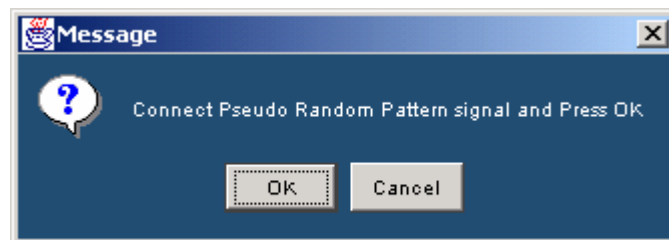

Figure 3-142: PRP message box

The application tests the signal with Low / High Amplitude eye mask and displays the results.

- If you have selected **File> Preferences> Advanced> Cable Eye Diagram Test Point> Test at TP3**, click here for information on what the application does.
 1. The application displays the message, "Connect TPA-R signal and press OK".
 2. Connect the cable to the ESB board and the other end to TPA-R. Probe the correct data pairs from TPA-R and press OK

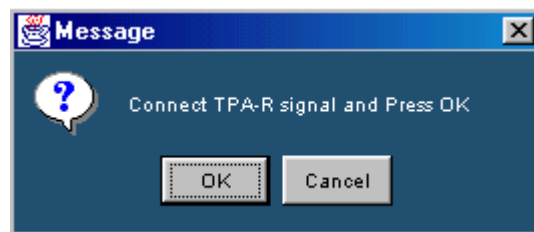

Figure 3-143: TPA-R signal message box

The application tests the signal with the cable limit eye mask and displays the results.

*Note: If you have selected **File > Preferences > Advanced > Cable Eye Diagram Test Point > Test at TP2 & TP3**, you can generate reports only when the TP3 result is available (Pass or Fail). If you try to generate a report, the application displays the following error message box*

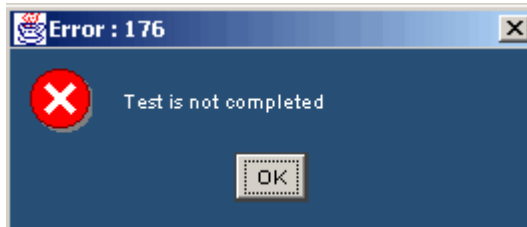

Figure 3-144: Test not completed message box

Viewing Results: High-Amplitude/Low-Amplitude Eye Diagram

Follow these steps to view High-Amplitude/Low-Amplitude Eye Diagram results:

1. Select **Results > Result Detail** to display the detailed results for the Cable **High/Low-Amplitude** Measurement.

You can also use the:

- **Compare Result** button to compare results
- **Generate Report** button to generate reports

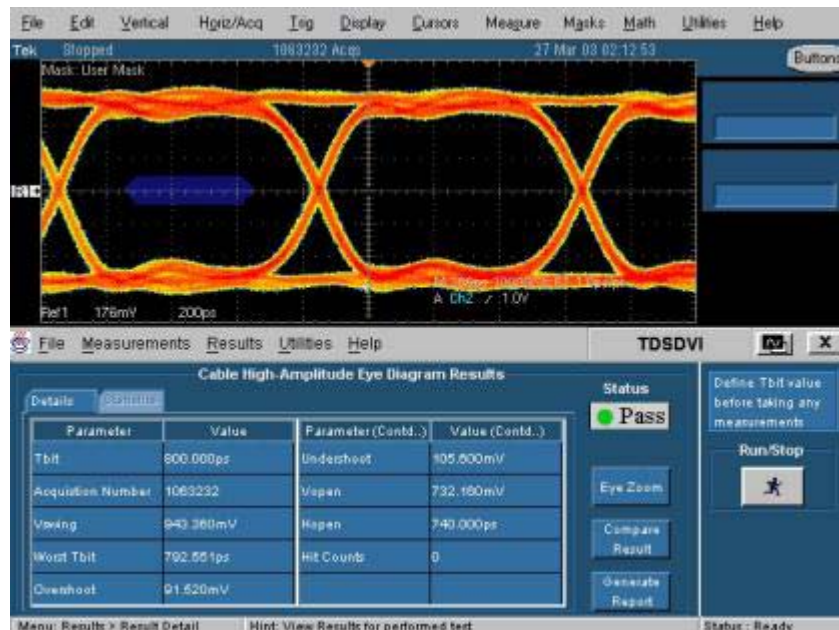

Figure 3-145: High-Amplitude Eye Diagram results

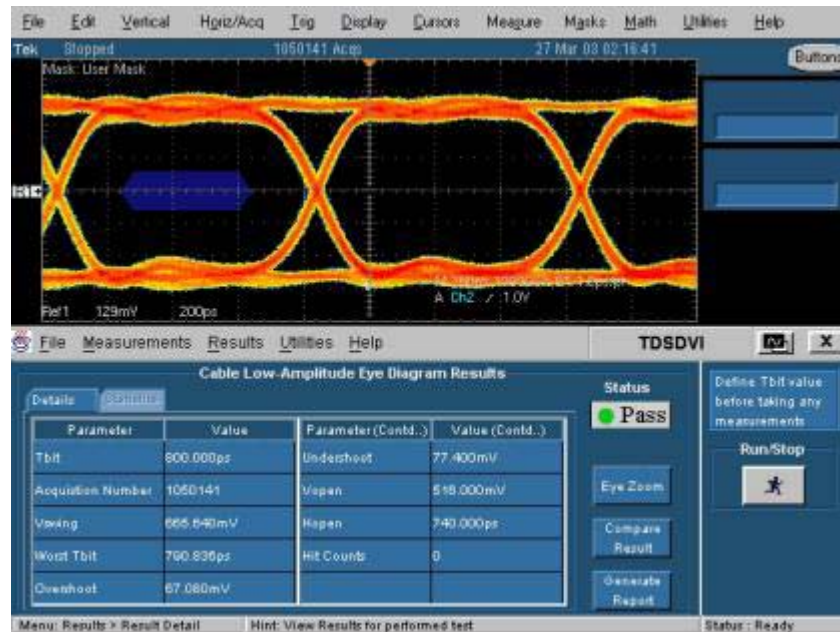

Figure 3-146: Low-Amplitude Eye Diagram results

Table 3-22 lists the high/low amplitude eye diagram result options and their descriptions.

Table 3-22: Results: High-Amplitude/Low-Amplitude Eye Diagram options and their descriptions

Results	Description
Parameter	Displays the calculated parameters for the measurement such as, Tbit, Acquisition Number, Vswing, Worst Tbit, Overshoot, Undershoot, Vopen, Hopen and the number of Hit Counts
Value	Displays the values of: <ul style="list-style-type: none"> ▪ Tbit used to calculate the coordinates of the eye mask ▪ The number of acquisitions to create the eye diagram ▪ Calculated Vswing in volts ▪ Calculated Worst Tbit which is the minimum horizontal opening or time in the displayed eye in seconds ▪ Calculated Overshoot and Undershoot of the eye diagram ▪ Vopen in volts and Hopen in seconds ▪ The number of Hit counts on the eye mask
Status	Displays the result status: Pass or Fail

Generating Reports Follow these steps to generate a report for all the measurements:

***Note:** Select **File> Export Setup> Images> Data Format** from the oscilloscope menu. Set the data format option to .jpg before generating a report. The report format does not support any other image file. Before you run the measurement, select **Automatic IDs & Report Names** to automatically generate a report.*

1. Select **Reports> Report Generation** to display the following screen.

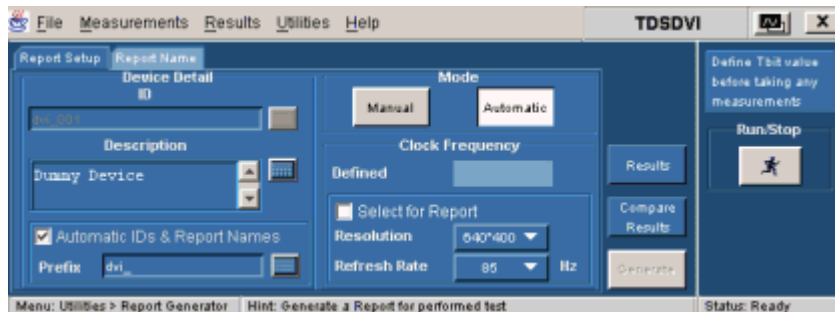

Figure 3-147: Generate report, report setup

2. In the **Report Setup** tab, use the virtual keypad to enter the device **ID**.
3. In the **Description** field, use the virtual keypad to enter the device description.
4. If you have not yet run the measurement, and if you want the application to display the device ID and specify the report names automatically, select the **Automatic IDs & Report Names** checkbox. The ID field is disabled if you select this option. The ID, File Name fields, and Generate button are disabled if this option is selected.
5. In the **Prefix** field, use the virtual keypad to enter the device prefix.
6. Select the **Mode** of generating the report: **Manual or Automatic**. If you select the Manual mode, the Prefix field is disabled. If you select the Automatic mode, Device ID field is disabled.
7. The **Defined** field displays the predefined clock frequency values automatically when you define and calculate Tbit.
8. Use the drop-down arrow in the **Resolution** and **Refresh Rate** field to set the values and calculate the clock frequency. The drop-down list provides the Resolution and Refresh Rate values according to the VESA standard. If you select the **Select for Report** check box, the application displays the resolution and refresh rate in the generated report.
9. If you do not want to specify the report details, select the **Generate** button. You can do this only if you have selected the Manual mode of generating a report. If you want to specify the report details, perform the following steps:

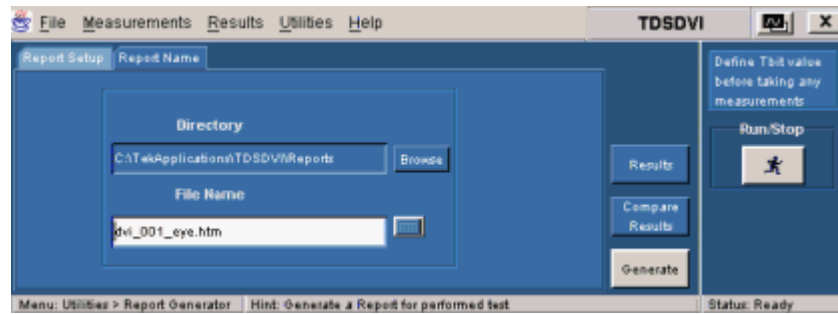

Figure 3-148: Generate report, report name

1. In the **Report Name** tab, select the **Browse** button in the **Directory** field to browse to the directory location.
2. In the **File Name** field, use the virtual keypad to enter the file name.
3. You can use the Results option to view the results and the Compare Results option to compare results of two different devices.
4. Select the **Generate** button to generate report an HTML report

How to Test Cable for Pk-Pk Jitter

Selecting and Configuring Measurements:Pk-Pk Jitter

Measurement> Select> Transmitter> Pk-Pk Jitter
Measurement> Select> Cable> Pk-Pk Jitter

Note: Refer page140 to setup the DUT before using the application for Transmitter Pk-Pk Jitter.

Note: Refer page149 to setup the DUT before using the application for Cable Pk-Pk Jitter

*Note: To get appropriate results in Pk-Pk Jitter measurements, from the oscilloscope menu bar, select **Measure->Waveform Histograms->Adjust Histogram Box Limits**.*

Follow these steps to select and configure Pk-Pk Jitter:

1. Select **Measurements> Select> Transmitter/Cable> Pk-Pk Jitter** to display the screen.

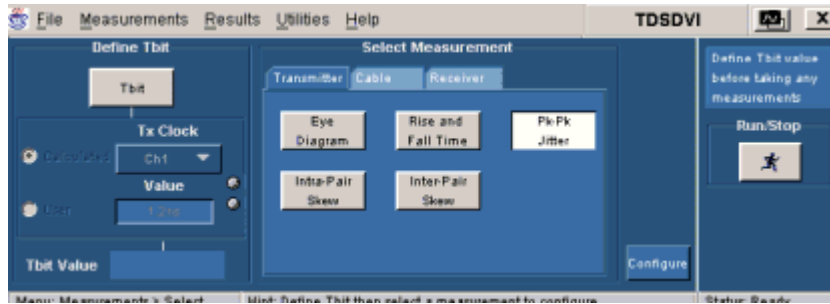

Figure 3-149: Transmitter Pk-Pk Jitter pane

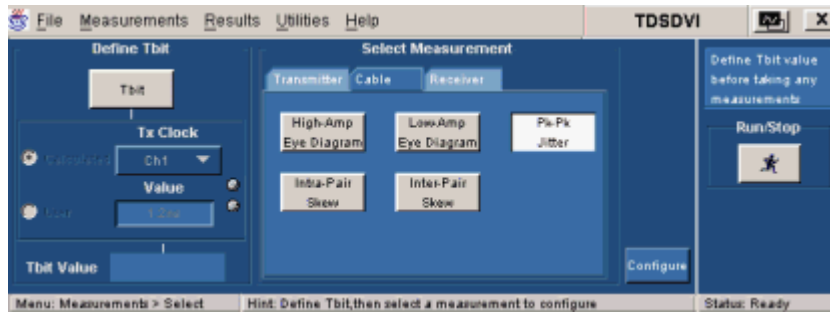

Figure 3-150: Cable Pk-Pk Jitter pane

2. You have to define Tbit:
 - If you have not calculated the Tbit value
 - If you have changed the device, resolution, refresh rate or the blanking rate after calculating the Tbit
3. Select the **Configure** button to display the following screen:

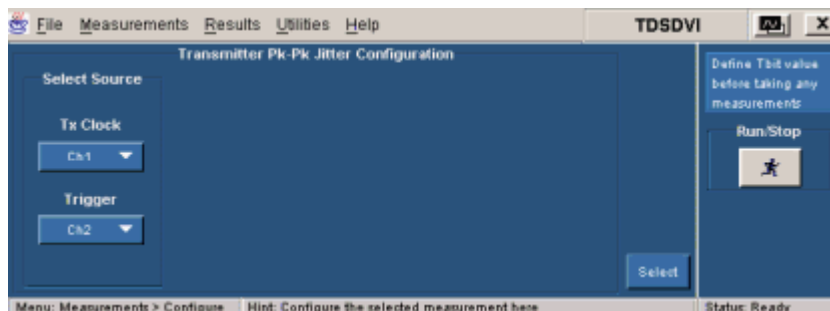

Figure 3-151: Transmitter Pk-Pk Jitter configuration

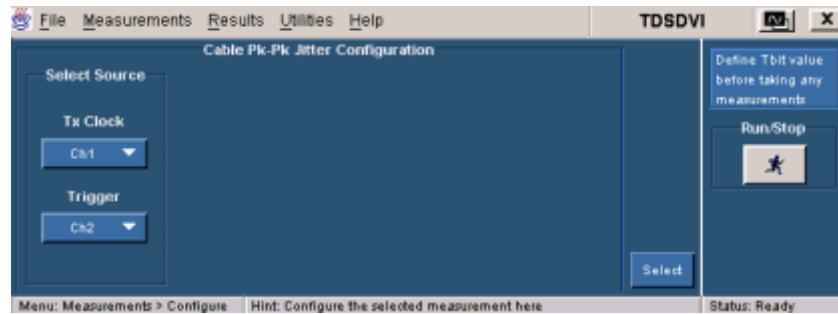



Figure 3-152: Cable Pk-Pk Jitter configuration

4. Select the transmitted differential clock source from the **Tx Clock** drop-down list. The available selections are: Ch1 to Ch4. The application requires a CRU (Clock Recovery Unit) to trigger the oscilloscope. Set the trigger source channel from the **Trigger** drop-down list. Data and Trigger source are mutually exclusive.
5. Press the **Run** button  to perform the test. The application displays the Confirm Tbit Value message box.
6. Confirm the Tbit value to display the next message box. Connect the clock signals and press **Ok**.

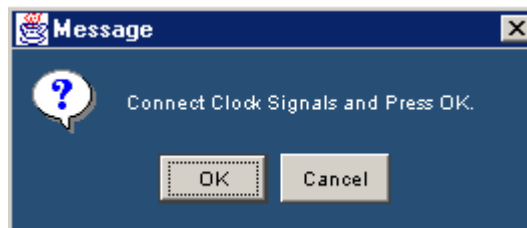

Figure 3-153: Clock signals message box

The application calculates the Pk-PK Jitter and displays the result: Pass or Fail.

Note: For more in-depth analysis on Jitter, use the TDSJIT3 Package.

If the signal is unstable, the application cannot place the histogram at the second rising edge of the clock signal, then the application displays the following message box.

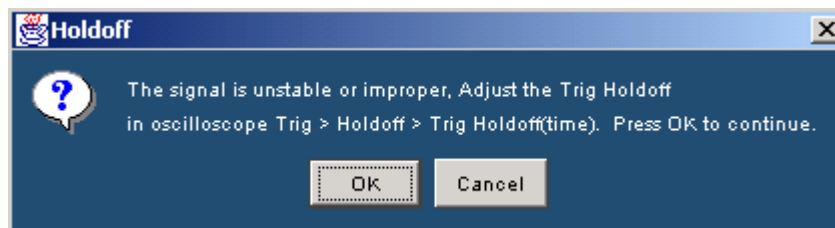

Figure 3-154: Holdoff message box

To adjust the Trigger Holdoff time,

1. Select **Trig > Holdoff** from the oscilloscope interface as shown in Figure 3-154.
2. Use the GP knob on the oscilloscope panel to adjust the trigger hold off time.
3. After stabilizing the signal, press the **APP** button in the oscilloscope interface to display the application.
4. Press **OK** in Figure 3-153 Holdoff message box to continue the peak to peak jitter measurement and **Cancel** to stop running the measurement.



Figure 3-155: Oscilloscope interface

Viewing Results-Pk-Pk Jitter

Follow these steps to view Pk-Pk Jitter results:

1. Select **Results > Result Detail** to display the detailed results for the Cable **Pk-Pk Jitter** measurement.

You can also use the:

- **Compare Result** button to compare results
- **Generate Report** button to generate reports

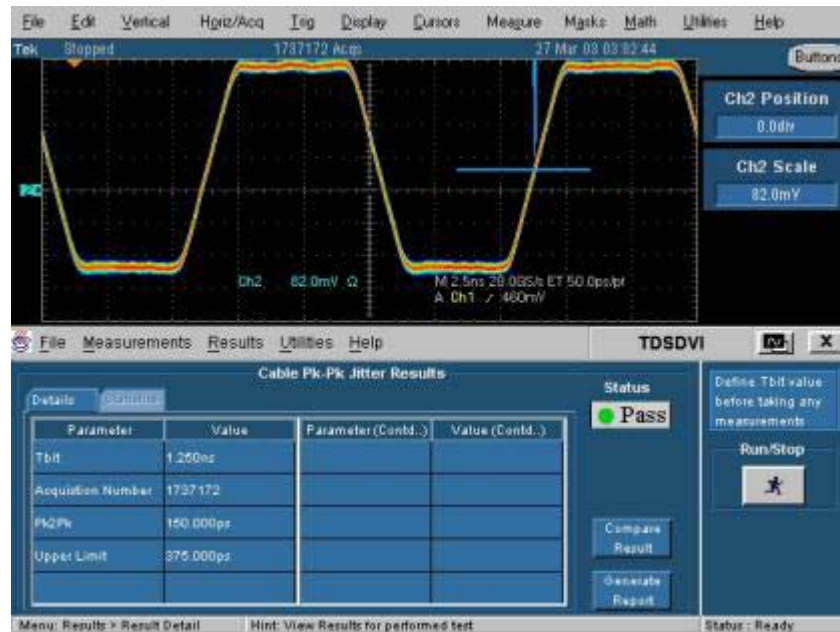

Figure 3-156: Rise and Fall Time results-Details

Table 3-23 lists the pk-pk jitter result options and their descriptions.

Table 3-23: Results: Pk-Pk Jitter options and their descriptions

Results	Description
Parameters	Displays the calculated parameters for the measurement such as, Tbit, Acquisition Number, PK2Pk and its Upper Limit.
Value	Displays the values of: <ul style="list-style-type: none"> ▪ Tbit used for calculating the peak to peak jitter limit in seconds ▪ The number of acquisitions to create the histogram ▪ The measured peak to peak jitter in seconds ▪ The maximum limit for Jitter. The values above this limit indicate a Fail
Status	Displays the result status: Pass or Fail

Generating Reports Follow these steps to generate a report for all the measurements:

Note: Select File> Export Setup> Images> Data Format from the oscilloscope menu. Set the data format option to .jpg before generating a report. The report format does not support any other image file. Before you run the measurement, select Automatic IDs & Report Names to automatically generate a report.

1. Select **Reports> Report Generation** to display the following screen.

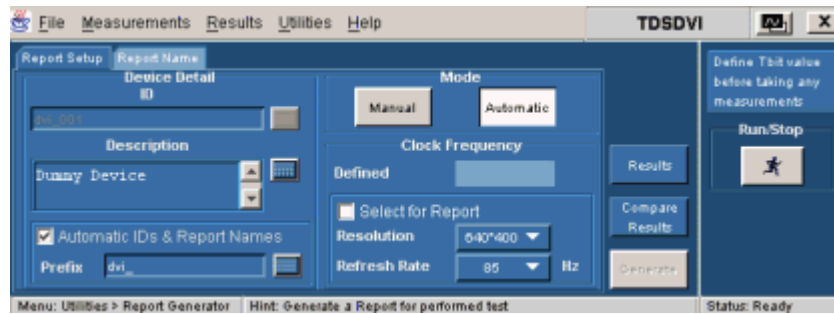

Figure 3-157: Generate report, report setup

2. In the **Report Setup** tab, use the virtual keypad to enter the device **ID**.
3. In the **Description** field, use the virtual keypad to enter the device description.
4. If you have not yet run the measurement, and if you want the application to display the device ID and specify the report names automatically, select the **Automatic IDs & Report Names** checkbox. The ID field is disabled if you select this option. The ID, File Name fields, and Generate button are disabled if this option is selected.
5. In the **Prefix** field, use the virtual keypad to enter the device prefix.
6. Select the **Mode** of generating the report: **Manual or Automatic**. If you select the Manual mode, the Prefix field is disabled. If you select the Automatic mode, Device ID field is disabled.
7. The **Defined** field displays the predefined clock frequency values automatically when you define and calculate Tbit.
8. Use the drop-down arrow in the **Resolution** and **Refresh Rate** field to set the values and calculate the clock frequency. The drop-down list provides the Resolution and Refresh Rate values according to the VESA standard. If you select the **Select for Report** check box, the application displays the resolution and refresh rate in the generated report.
9. If you do not want to specify the report details, select the **Generate** button. You can do this only if you have selected the Manual mode of generating a report. If you want to specify the report details, perform the following steps:

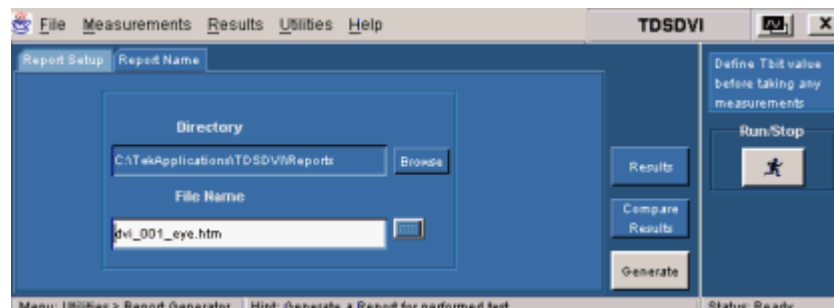

Figure 3-158: Generate report, report name

1. In the **Report Name** tab, select the **Browse** button in the **Directory** field to browse to the directory location.
2. In the **File Name** field, use the virtual keypad to enter the file name.
3. You can use the Results option to view the results and the Compare Results option to compare results of two different devices.
4. Select the **Generate** button to generate report an HTML report.

How to Test Cable for Intra-Pair Skew

Selecting and Configuring Measurements: Intra-Pair Skew

Measurement> Select> Transmitter>Intra-Pair Skew
 Measurement> Select> Cable> Intra-Pair Skew

Note: Refer page 143 to setup the DUT before using the application for Transmitter Intra-Pair Skew.

Note: Refer page 150 to setup the DUT before using the application for Cable Intra-Pair Skew.

Follow these steps to select and configure Intra-Pair Skew:

1. Select **Measurements> Select> Transmitter/Cable> Intra-Pair Skew** to display the following screen.

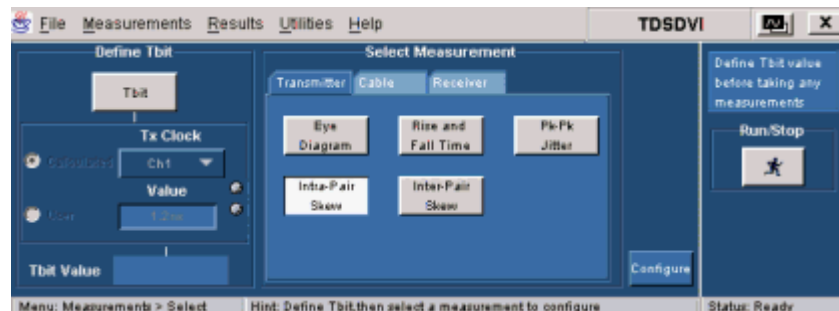

Figure 3-159: Transmitter Intra-Pair Skew pane

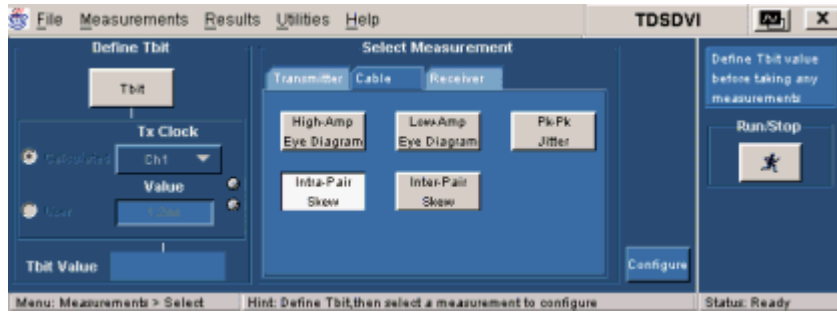

Figure 3-160: Cable Intra-Pair Skew pane

2. You have to define Tbit:
 - If you have not calculated the Tbit value
 - If you have changed the device, resolution, refresh rate or the blanking rate after calculating the Tbit
3. Select the **Configure** button to display the following screen.

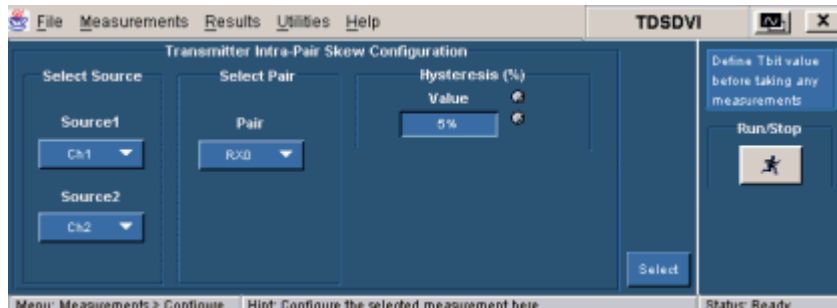

Figure 3-161: Transmitter Intra-Pair Skew configuration

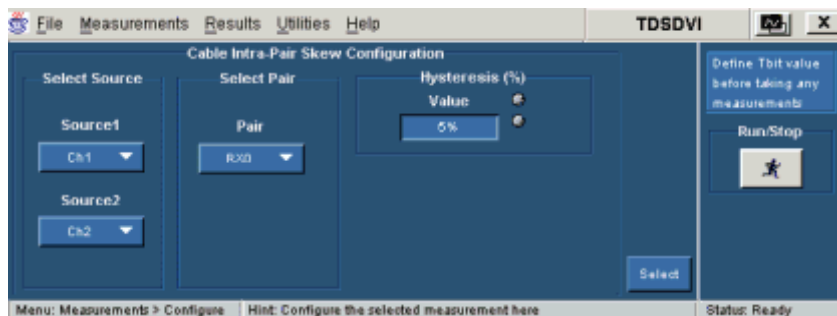



Figure 3-162: Cable Intra-Pair Skew configuration

4. Set the data line (+ or -) of a data pair in the **Source** drop-down list. The available selections are: Ch1 to Ch4. The Source channels are mutually exclusive. Use two single-ended probes to connect the data pair (for example: Rx0+ or Rx0-) to Source1 and Source2.
5. Set the data pair in the **Pair** drop down list. The available selections are:
 - RX0

- RX1
 - RX2
6. In the **Hysteresis** field, use the calculator keypad or the GP knob to enter the hysteresis percentage value. The range for the hysteresis is 2% to 10%.
 7. Press the **Run** button  to perform the test. The application displays the Confirm Tbit Value message box.
 8. Select **Yes** to display the next message box. Connect the data signals and press **OK**.

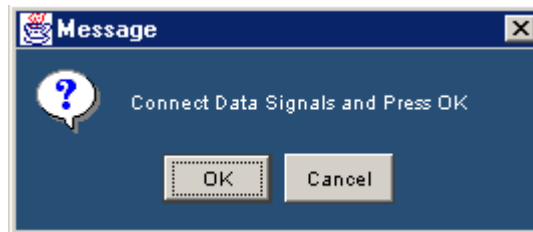

Figure 3-163: Data signals message box

The application calculates the Intra-Pair Skew and displays the result: Pass or Fail.

Viewing Results: Intra-Pair Skew

Follow these steps to view Intra-Pair Skew results:

1. Select **Results> Result Detail** to display the detailed results for the Cable **Intra-Pair Skew** measurement.

You can also use the:

- **Compare Result** button to compare results
- **Generate Report** button to generate reports



Figure 3-164: Cable Intra-Pair Skew results

Table 3-24 lists the intra-pair skew result options and their descriptions.

Table 3-24: Results: Intra-Pair Skew options and their descriptions

Results	Description
Details tab	
Parameter	Displays the calculated parameters for the measurement such as, Tbit, Skew and its Upper Limit.
Values	Displays the values of: <ul style="list-style-type: none"> Tbit used for calculating the intra-pair skew limits in seconds The measured skew in seconds The maximum limit for Intra-Pair Skew. Values above this limit indicate a Fail
Statistics tab	
Measurement	Displays the selected measurement.
Population	The number of edges calculated in the acquired waveform.
Min	The minimum intra-pair skew value in the acquired waveform.
Max	The maximum intra-pair skew value in the acquired waveform.
Mean	The average of all the calculated intra-pair skew values.
Std Dev	The standard deviation of all the calculated intra-pair skew values.
Status	Displays the result status: Pass or Fail. This is common for the Details and the Statistics tab.

Generating Reports Follow these steps to generate a report for all the measurements:

*Note: Select **File> Export Setup> Images> Data Format** from the oscilloscope menu. Set the data format option to .jpg before generating a report. The report format does not support any other image file. Before you run the measurement, select **Automatic IDs & Report Names** to automatically generate a report.*

1. Select **Reports> Report Generation** to display the following screen.

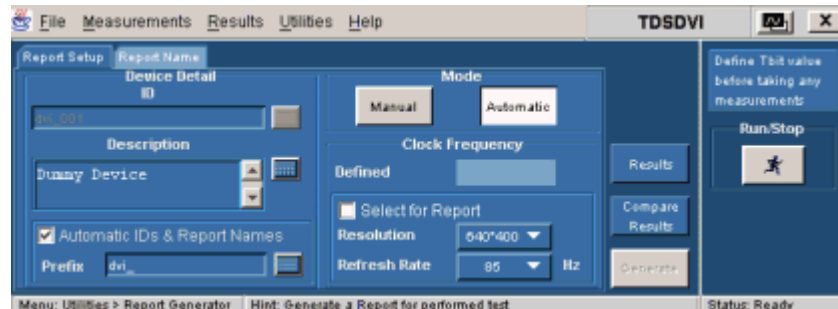

Figure 3-165: Generate report, report setup

2. In the **Report Setup** tab, use the virtual keypad to enter the device **ID**.
3. In the **Description** field, use the virtual keypad to enter the device description.
4. If you have not yet run the measurement, and if you want the application to display the device ID and specify the report names automatically, select the **Automatic IDs & Report Names** checkbox. The ID field is disabled if you select this option. The ID, File Name fields, and Generate button are disabled if this option is selected.
5. In the **Prefix** field, use the virtual keypad to enter the device prefix.
6. Select the **Mode** of generating the report: **Manual or Automatic**. If you select the Manual mode, the Prefix field is disabled. If you select the Automatic mode, Device ID field is disabled.
7. The **Defined** field displays the predefined clock frequency values automatically when you define and calculate Tbit.
8. Use the drop-down arrow in the **Resolution** and **Refresh Rate** field to set the values and calculate the clock frequency. The drop-down list provides the Resolution and Refresh Rate values according to the VESA standard. If you select the **Select for Report** check box, the application displays the resolution and refresh rate in the generated report.
9. If you do not want to specify the report details, select the **Generate** button. You can do this only if you have selected the Manual mode of generating a report. If you want to specify the report details, perform the following steps:

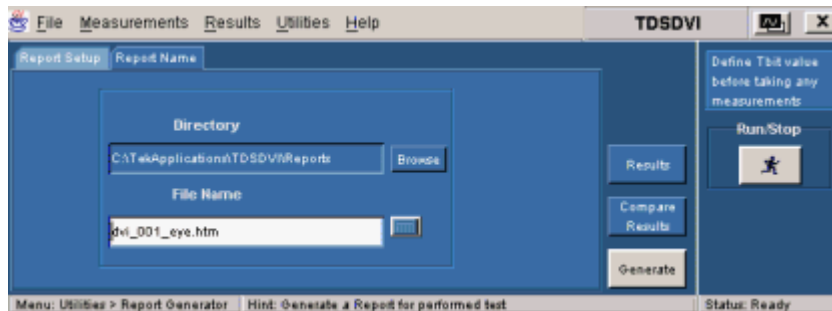

Figure 3-166: Generate report, report name

1. In the **Report Name** tab, select the **Browse** button in the **Directory** field to browse to the directory location.
2. In the **File Name** field, use the virtual keypad to enter the file name.
3. You can use the **Results** option to view the results and the **Compare Results** option to compare results of two different devices.
4. Select the **Generate** button to generate report an HTML report

How to Test Cable for Inter-Pair Skew

Selecting and Configuring Measurements: Inter-Pair Skew

Follow these steps to select and configure Inter-Pair Skew:

Note: Refer page 153 to setup the DUT before using the application.

1. Select **Measurements> Select>Cable> Inter-Pair Skew** to display the following screen.

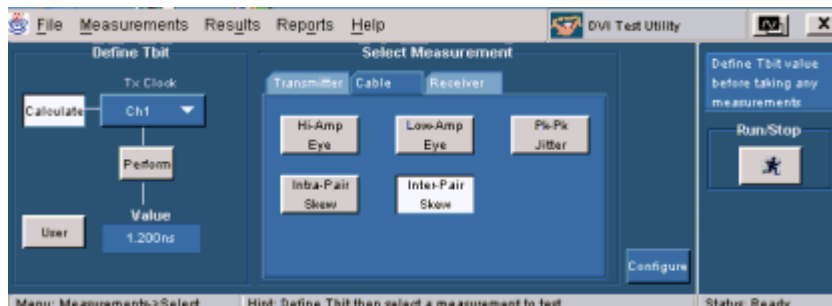

Figure 3-167: Inter-Pair Skew pane

2. You have to define Tbit:
 - If you have not calculated the Tbit value

- If you have changed the device, resolution, refresh rate or the blanking rate after calculating the Tbit
3. Select the **Configure** button to display the following screen.

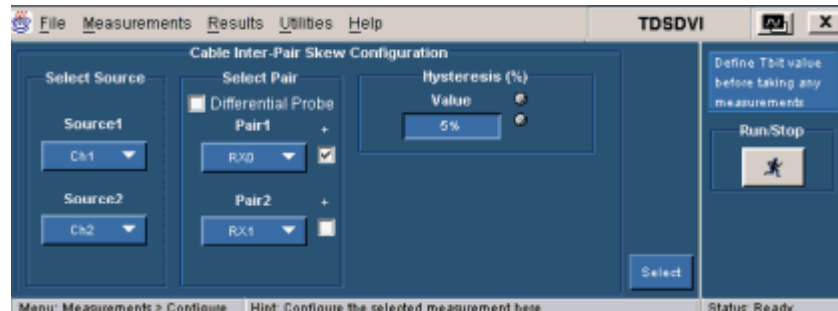



Figure 3-168: Inter-Pair Skew configuration

4. In the **Select Source** pane, select the channel connected in the TPA-P fixture with a differential probe from the **Source1** and **Source2** field drop down list. The available selections are: Ch1 to Ch4. The application requires a recovered clock as an external trigger source to the oscilloscope. If you select the Differential Probe check box, the positive check boxes next to the pair fields are disabled. Set the data pair in the **Select Pair** drop down list to set the data pair. The available selections are:
- RX0
 - RX1
 - RX2

If the data line is positive, select the check box next to the **Pair1** and **Pair2** fields. You cannot select the same data pair in the **Pair1** and **Pair2** fields regardless of the polarity (+ or -).

5. Press the **Run** button  to perform the test. The application displays the Confirm Tbit Value message box.
6. Select **Yes** to display the next message box. Connect the data signals and press **OK**.

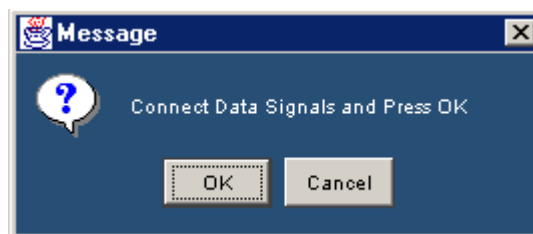

Figure 3-169: Data signals message box

The application calculates the Inter-Pair Skew and displays the result: Pass or Fail.

Viewing Results-Inter-Pair Skew Follow these steps to view Inter-Pair Skew results:

1. Select **Results> Result Detail** to display the detailed results for the Cable **Inter-Pair Skew** measurement.

You can also use the:

- **Compare Result** button to compare results
- **Generate Report** button to generate reports



Figure 3-170: Inter-Pair Skew results

Table 3-25 lists the inter-pair skew result options and their descriptions.

Table 3-25: Results: Inter-Pair Skew options and their descriptions

Results	Description
Details tab	
Parameter	Displays the calculated parameters for the measurement such as, Tbit, Skew and its Upper Limit.
Value	Displays the values of: <ul style="list-style-type: none"> ▪ Tbit used for calculating the inter-pair skew limits in seconds ▪ The measured skew in seconds ▪ The maximum limit for inter-pair skew. Values above this limit indicate a Fail

Statistics tab

Measurement	Displays the selected measurement.
Population	The number of edges calculated in the acquired waveform.
Min	The minimum inter-pair skew values in the acquired waveform.
Max	The maximum inter-pair skew values in the acquired waveform.
Mean	The average of all the calculated inter-pair skew values.
Std Dev	The standard deviation of all the calculated inter-pair skew values.
Status	Displays the result status: Pass or Fail. This is common to the Details and the Statistics tab.

Generating Reports Follow these steps to generate a report for all the measurements:

*Note: Select **File> Export Setup> Images> Data Format** from the oscilloscope menu. Set the data format option to .jpg before generating a report. The report format does not support any other image file. Before you run the measurement, select **Automatic IDs & Report Names** to automatically generate a report.*

1. Select **Reports> Report Generation** to display the following screen.

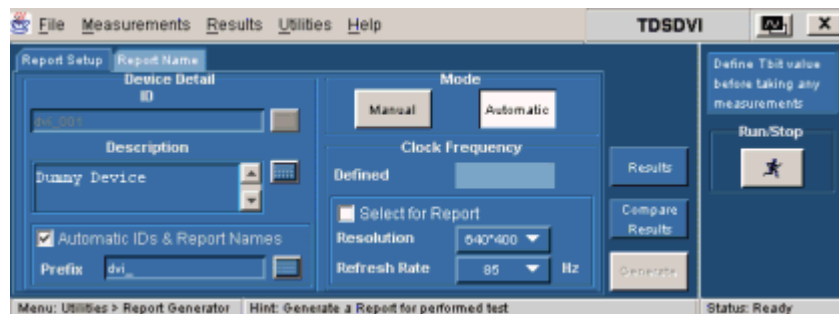

Figure 3-171: Generating reports, report setup

2. In the **Report Setup** tab, use the virtual keypad to enter the device **ID**.
3. In the **Description** field, use the virtual keypad to enter the device description.
4. If you have not yet run the measurement, and if you want the application to display the device ID and specify the report names automatically, select the **Automatic IDs & Report Names** checkbox. The ID field is disabled if you select this option. The ID, File Name fields, and Generate button are disabled if this option is selected.
5. In the **Prefix** field, use the virtual keypad to enter the device prefix.
6. Select the **Mode** of generating the report: **Manual or Automatic**. If you select the Manual mode, the Prefix field is disabled. If you select the Automatic mode, Device ID field is disabled.

7. The **Defined** field displays the predefined clock frequency values automatically when you define and calculate Tbit.
8. Use the drop-down arrow in the **Resolution** and **Refresh Rate** field to set the values and calculate the clock frequency. The drop-down list provides the Resolution and Refresh Rate values according to the VESA standard. If you select the **Select for Report** check box, the application displays the resolution and refresh rate in the generated report.
9. If you do not want to specify the report details, select the **Generate** button. You can do this only if you have selected the Manual mode of generating a report. If you want to specify the report details, perform the following steps:

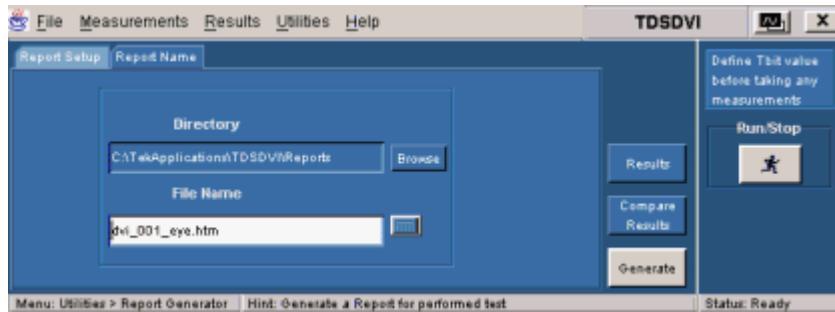

Figure 3-172: Generating reports, report name

1. In the **Report Name** tab, select the **Browse** button in the **Directory** field to browse to the directory location.
2. In the **File Name** field, use the virtual keypad to enter the file name.
3. You can use the Results option to view the results and the Compare Results option to compare results of two different devices.
4. Select the **Generate** button to generate report an HTML report.

How to Test Receiver For High-Amplitude/Low-Amplitude Eye Diagram

Selecting and Configuring Measurements: High-Amplitude/Low-Amplitude Eye Diagram

Follow these steps to select and configure High-Amplitude/Low-Amplitude Eye Diagram:

Note: Refer page160 to setup the DUT before using the application.

1. Select the **Measurements> Select> Receiver** tab to display the following screen. Select **High-Amplitude/Low-Amplitude Eye Diagram**.

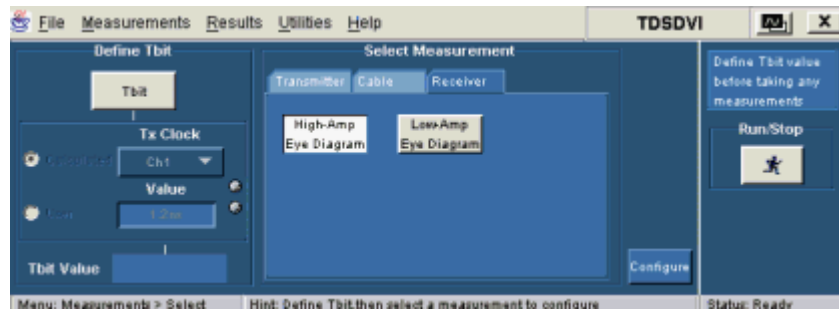

Figure 3-173: Receiver High-Amplitude Eye Diagram pane

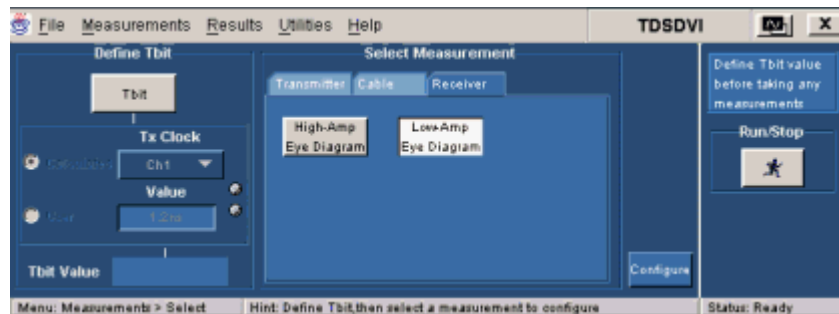

Figure 3-174: Receiver Low-Amplitude Eye Diagram pane

2. You have to define Tbit:
 - If you have not calculated the Tbit value
 - If you have changed the device, resolution, refresh rate or the blanking rate after calculating the Tbit
3. Select the **Configure** button to display the following screen:

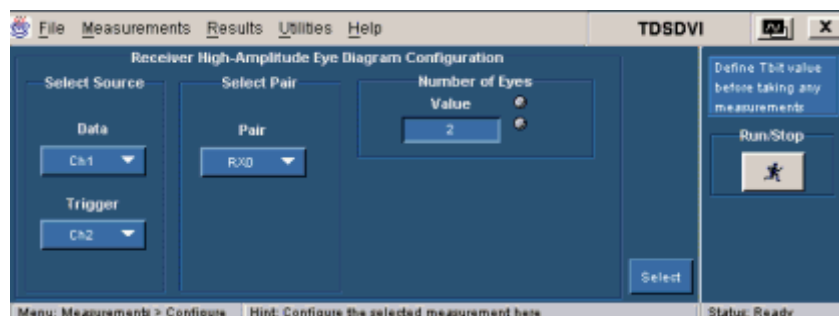

Figure 3-175: High-Amplitude configuration

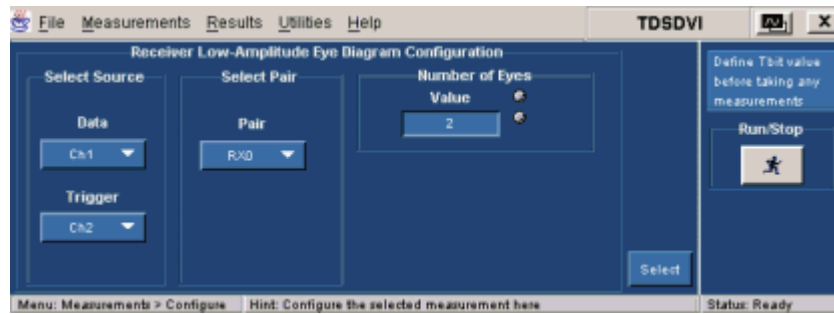



Figure 3-176: Low-Amplitude configuration

4. In the **Select Source** pane, select the data source channel from the **Data** drop-down list. The available selections are: Ch1 to Ch4. The application requires a recovered clock as an external trigger source to the oscilloscope. Use the drop-down arrow in the Trigger field to set the trigger source channel. The available selections are: Ch1 to Ch4. The Data and Trigger fields identify the data source and the external clock source. You cannot set the same channel for Data and Trigger source.
5. Use the drop-down arrow in the **Select Pair** field to set the data pair. The available data pairs are: Rx0, Rx1 and Rx2.

***Note:** The data pair values appear only in the generated report. They are not used for any calculations.*

6. In the **Number of Eyes** field, use the calculator keypad  or the GP knob next to the **Value** field to set the minimum number of eyes required to perform Receiver Eye measurement. After you set the minimum number of eyes, the worst eye is placed in the eye mask.
7. Press the **Run** button  to perform the test. The application displays the Confirm Tbit Value message box.
8. If you are sure you have defined the Tbit value, the application displays the following message box. If you select **OK**, the application deletes the previous Ref1 waveform and stores the current eye diagram results in the Ref1 waveform.

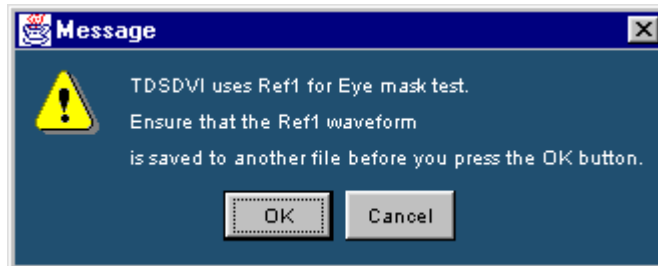

Figure 3-177: Ref1 message box

This message box will appear only if you have selected **File> Preferences> General> Ref waveform** deletion prompt for Eye checkbox.

9. Select **OK** to display the next message box. Select the PRP pattern in the Equivalent Source Board (ESB) and connect the signal from the TPA-R fixture and press **OK**. See page 184 for information about TPA-P fixture connections.

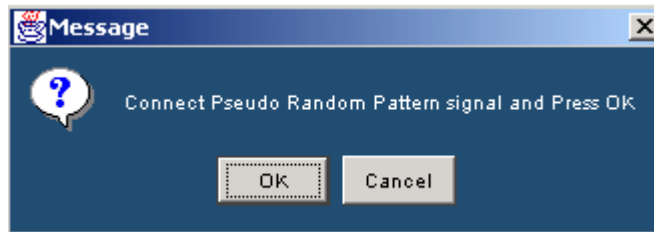

Figure 3-178: PRP message box

10. If you are using a TDS6604, TDS6404, TDS6604B, or TDS6804B oscilloscope, click here for information.

1. The application displays the Monitor Eye Progress message box.

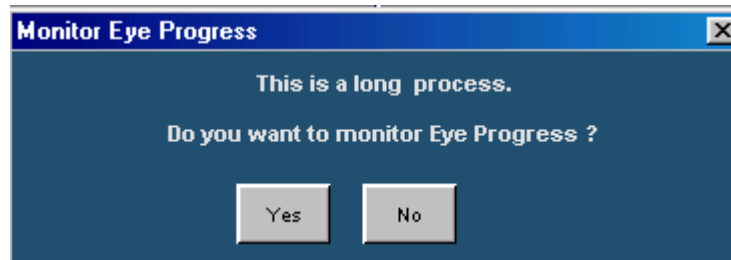

Figure 3-179: Monitor eye progress message box

2. Select Yes to display the Eye Zoom screen and No to display the results pane and wait till the application displays the results.

If you have selected **File> Preferences> General> Use cursors for Eye, RT & FT Testing**, see page 182 for information on what the application does further.

The application tests the signal with the receiver low/high amplitude eye mask and displays the results.

Viewing Results: High-Amplitude/Low-Amplitude Eye Diagram

Follow these steps to view High-Amplitude/Low-Amplitude Eye Diagram results:

1. Select **Results> Result Detail** to display the detailed results for the Receiver **High-Amplitude/Low-Amplitude Eye Diagram** measurement.

You can also use the:

- **Compare Result** button to compare results
- **Eye Zoom** button to view the zoomed eye
- **Generate Report** button to generate reports

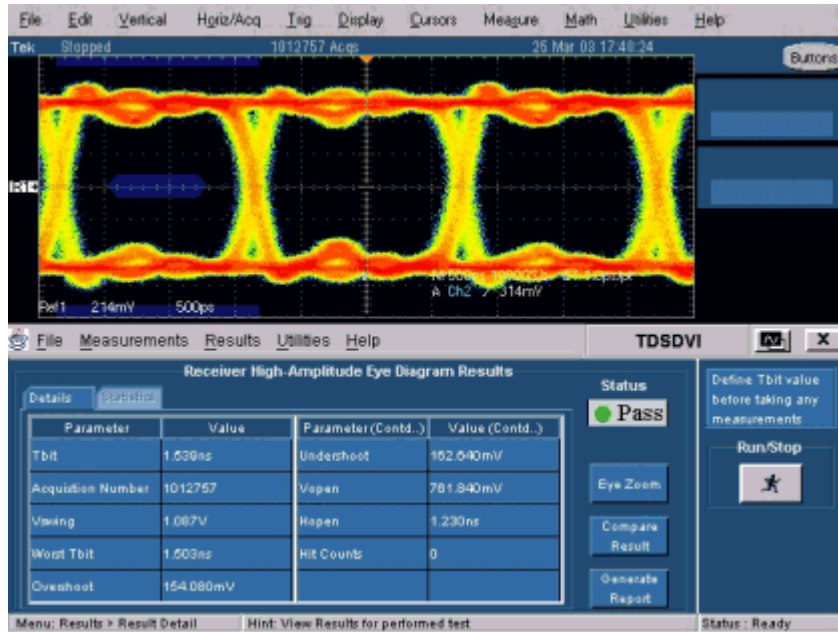

Figure 3-180: High-Amplitude Eye Diagram results



Figure 3-181: Low-Amplitude Eye diagram results

Table 3-26 lists the high/low amplitude eye diagram result options and their descriptions.

Table 3-26: Results: High-Amplitude/Low Amplitude Eye Diagram options and their descriptions

Results	Description
Parameter	Displays the calculated parameters for the measurement such as, Tbit, Acquisition Number, Vswing, Worst Tbit, Overshoot, Undershoot, Vopen, Hopen and the Hit Counts.
Value	Displays the values of: <ul style="list-style-type: none"> ▪ Tbit used for calculating the co-ordinates of the eye mask ▪ Calculated Worst Tbit in the displayed eyes in seconds ▪ The number of acquisitions to create the eye diagram ▪ Calculated Vswing in volts ▪ Calculated Overshoot, Undershoot of the eye diagram ▪ Vopen in volts and Hopen in seconds ▪ The number of Hit counts on the eye mask
Status	Displays the result status: Pass or Fail.

Generating Reports Follow these steps to generate a report for all the measurements:

*Note: Select **File> Export Setup> Images> Data Format** from the oscilloscope menu. Set the data format option to .jpg before generating a report. The report format does not support any other image file. Before you run the measurement, select **Automatic IDs & Report Names** to automatically generate a report.*

1. Select **Reports> Report Generation** to display the following screen.

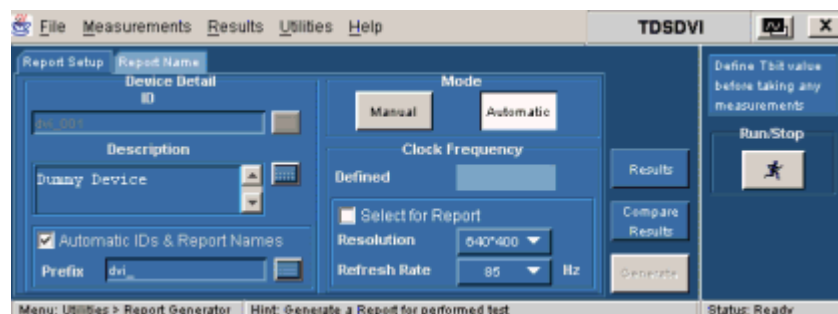

Figure 3-182: Generating reports, report setup

2. In the **Report Setup** tab, use the virtual keypad to enter the device **ID**.

3. In the **Description** field, use the virtual keypad to enter the device description.
4. If you have not yet run the measurement, and if you want the application to display the device ID and specify the report names automatically, select the Automatic IDs & Report Names checkbox. The ID field is disabled if you select this option. The ID, File Name fields, and Generate button are disabled if this option is selected.
5. In the **Prefix** field, use the virtual keypad to enter the device prefix.
6. Select the **Mode** of generating the report: **Manual or Automatic**. If you select the Manual mode, the Prefix field is disabled. If you select the Automatic mode, Device ID field is disabled.
7. The **Defined** field displays the predefined clock frequency values automatically when you define and calculate Tbit.
8. Use the drop-down arrow in the **Resolution** and **Refresh Rate** field to set the values and calculate the clock frequency. The drop-down list provides the Resolution and Refresh Rate values according to the VESA standard. If you select the **Select for Report** check box, the application displays the resolution and refresh rate in the generated report.
9. If you do not want to specify the report details, select the **Generate** button. You can do this only if you have selected the Manual mode of generating a report. If you want to specify the report details, perform the following steps:

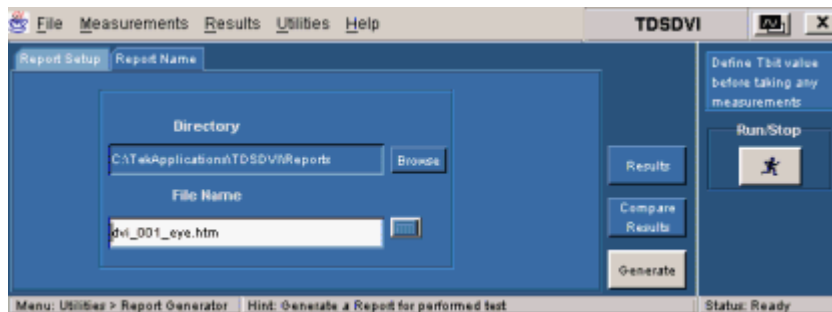

Figure 3-183: Generating reports, report name

1. In the **Report Name** tab, select the **Browse** button in the **Directory** field to browse to the directory location.
2. In the **File Name** field, use the virtual keypad to enter the file name.
3. You can use the Results option to view the results and the Compare Results option to compare results of two different devices.
4. Select the **Generate** button to generate report an HTML report.

Save and Recall Setups

Recall Default Setup To recall the default application settings:

1. Select **File> Recall default**. You will see the message, "Recall default will change the existing settings and restore the default settings. Do you wish to continue?"
2. Select **Yes** to change the current settings to the default settings. Select **No** to retain the current settings.

Save a Setup To save the application and oscilloscope settings to a setup file:

1. Select **File> Save**.
2. Select the directory.
3. Select or enter a file name with a .ini extension. If the file name does not have an ".ini" extension, the application adds a .ini extension. If you give an invalid extension, the application displays an error message "File name has an invalid extension".
4. Choose **Save**.

Note: The application also saves the oscilloscope settings to a ".set" file when you save the settings. Both the application ".ini" file and oscilloscope ".set" file have the same file name. While saving the settings, the application checks for the disk space available.

Recall a Setup To recall the application and oscilloscope settings from a saved setup file, follow these steps:

1. Select **File> Recall**.
2. Select the directory.
3. Select or enter a file name with a .ini extension. If the file name does not have a .ini extension, the application displays an error message "File does not exist."
4. Choose **Open** to recall the specified settings.
5. If the settings are recalled successfully, the application displays a message "File recalled successfully". If the settings are not recalled successfully, the application displays an error message.

Note: The application also recalls the oscilloscope setup from a ".set" file when you recall its setup.

Recall a Recently Recalled Setup

To recall the recent file settings, follow these steps:

1. Select **File> Recently Recalled** to display the last four recalled files.
2. If you recall the settings from any file in the recently recalled file list and the file already exists, the application displays a message "Do you want to recall the settings?". If you select **Yes**, the application recalls the settings. If you select **No**, the oscilloscope settings or the existing settings are retained.
3. The application reorders the list of recently recalled files. For example, if the order is file1, file2, file3 and file4, then, on selecting file3, the display order changes to file3, file1, file2 and file4.

Recall a Recently Saved Setup

To overwrite the settings of a file from the recently saved list, follow these steps:

1. Select **File> Recently Saved** to display the last four saved files.
2. If you save the settings in any one file from the recently saved file list and the file already exists, the application prompts a message to overwrite the settings. If you select **Yes**, the application overwrites the settings. If you select **No**, the settings are retained.
3. The application reorders the list of recently recalled files. For example, if the order is file1, file2, file3 and file4, then, on selecting file3, the display order changes to file3, file1, file2, and file4.

Note: *The application will not reorder the file list when the settings are saved to a file that appears as a first menu item in the recently saved file list.*

Application Examples

About Application Examples

This section presents many application examples.

To run the application examples, install and enable the application on the oscilloscope, connect the probes to the device under test, select and configure a measurement. To install the application, refer to the topic **Installation Procedures** on page 9. For more information on compatible probes, refer to the sections, **Compatibility** on page 7 and **Accessories** on page 8.

Tbit

Specifying the Equipment: Define Tbit You need the following equipment to setup the application and calculate Tbit:

- CSA7404, CSA7404B, TDS7404, TDS7404B, TDS7254, TDS7524B, TDS7704B, TDS6604, TDS6404, TDS6604B, TDS6804B oscilloscope with firmware version 2.2.0 or higher
- P7330, P7350 or P6330 (needs TCA-BNC adapter) differential probes
- TPA-P or TPA-R test fixture
- Device Under Test

Equipment Setup: Define Tbit To setup a device to measure **Tbit**, follow these steps:

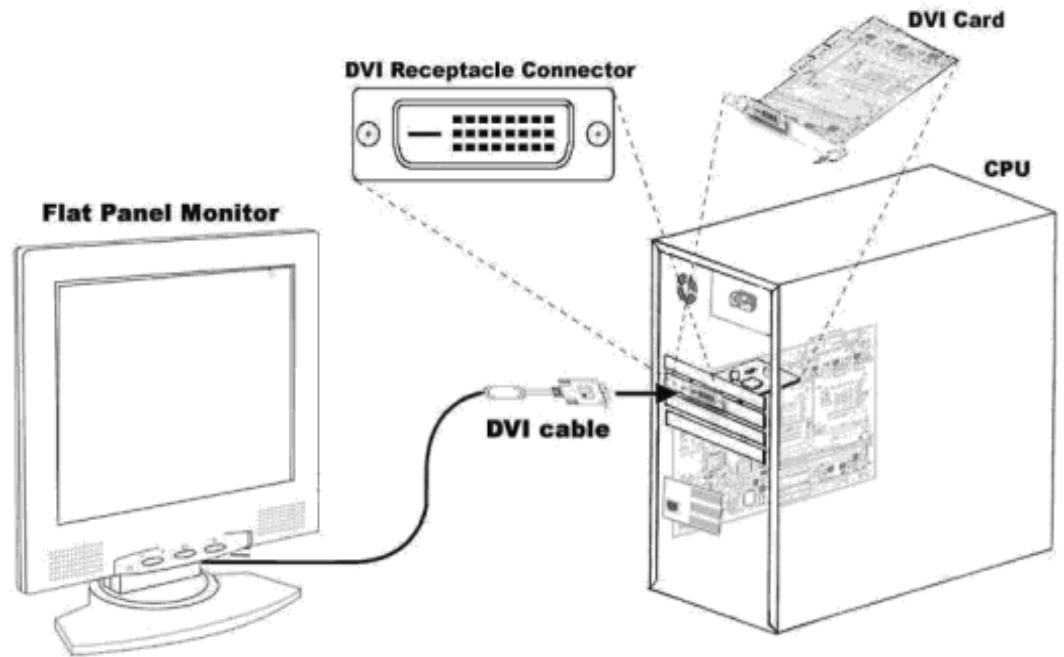
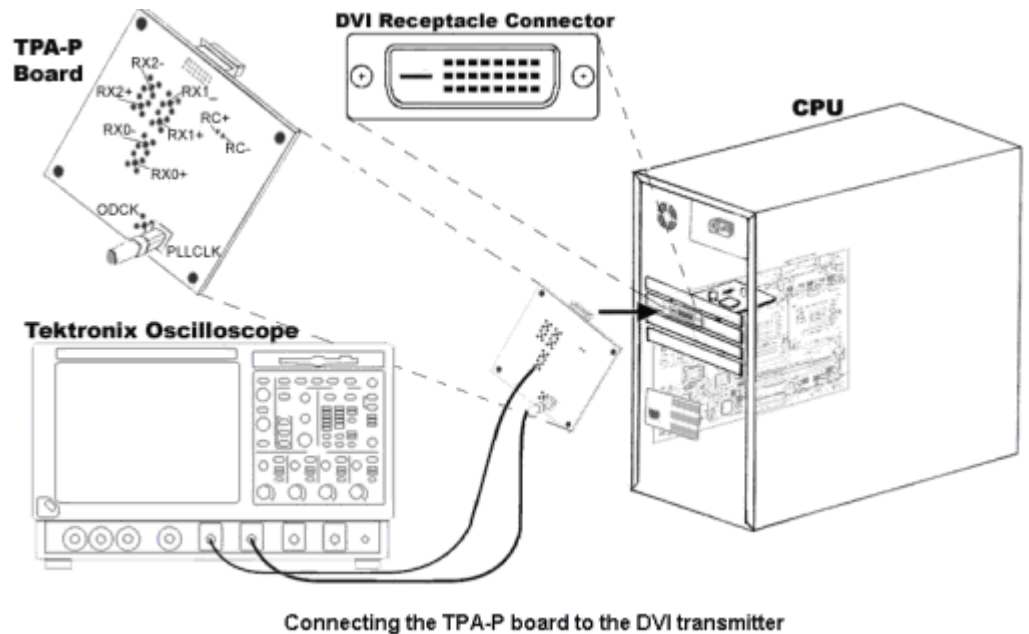

Figure 4-1: DVI monitor setup

1. Connect the DVI monitor to the DVI port of the AGP ADD Card in the PC as shown in the previous figure. Set the required screen resolution and the refresh rate. Set the host computer to run with a Half Clock Pattern to conduct the test. For information on how to set the host computer to run with a Half Clock Pattern to conduct the test, see page 182.
2. Remove the DVI monitor and attach the TPA-P fixture to the DVI port of the DUT.



Connecting the TPA-P board to the DVI transmitter

Figure 4-2: TPA-P fixture to the transmitter setup

3. Connect a P7350, P7330 or P6330 probe from any one of the four channels of the oscilloscope to the transmitted clock (Rxc+/-) on the TPA-P fixture. The next figure shows the test point for Rxc+/-.

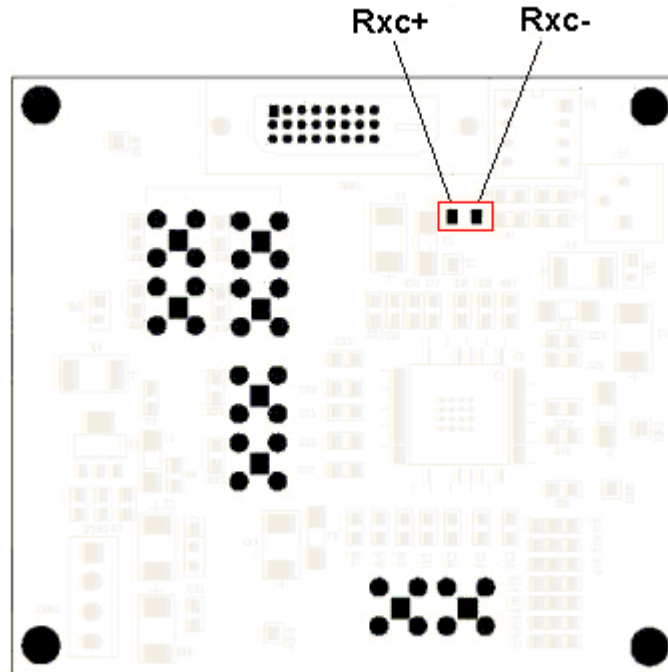

Setup for Tbit calculation

Figure 4-3: TPA-P test points

4. Configure the measurement and run the application.

Note: We recommend that you calculate the Tbit with the differential transmitted clock rather than defining Tbit values yourself. You need to calculate Tbit only once. This value will be retained for further measurements. If the device, resolution, blanking rate or the refresh rate changes, you have to recalculate Tbit.

Transmitter-Eye Diagram

Specifying the Equipment: You need the following equipment to setup the application and test Eye Diagram in a Transmitter:

Transmitter Eye Diagram

- CSA7404, CSA7404B, TDS7404, TDS7404B, TDS7254, TDS7524B, TDS7704B, TDS6604, TDS6404, TDS6604B, TDS6804B oscilloscope with firmware version 2.2.0 or higher
- P7330, P7350 or P6330 (needs TCA-BNC adapter) differential probes
- SMA cable

- TPA-P test fixture
- Device Under Test

**Equipment Setup-
Transmitter: Eye Diagram**

To setup a **Transmitter** to measure **Eye Diagram**, follow these steps:

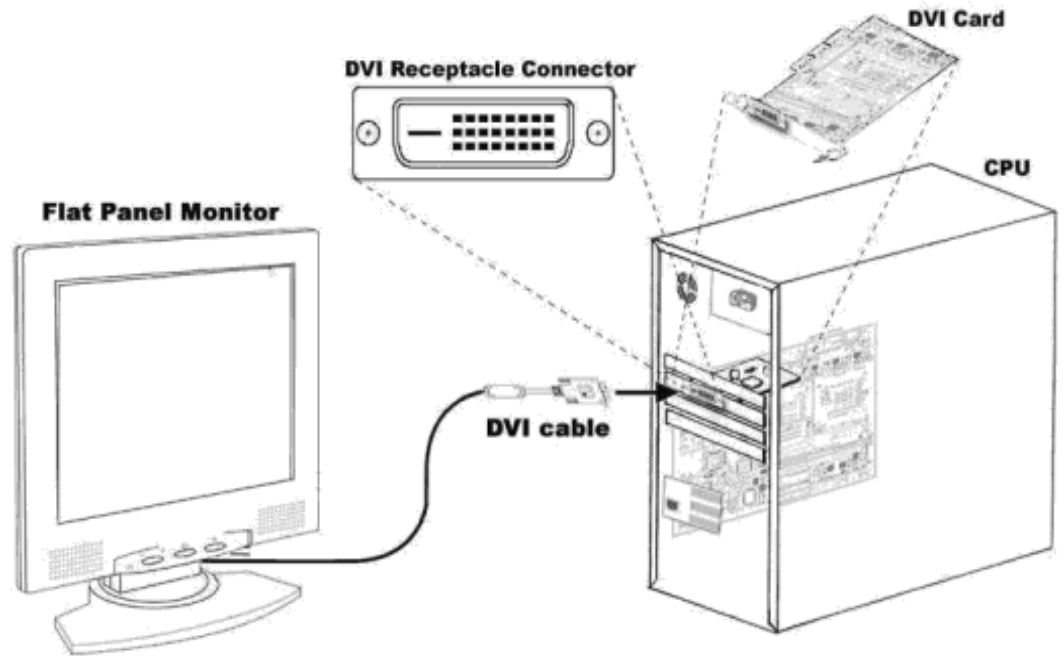
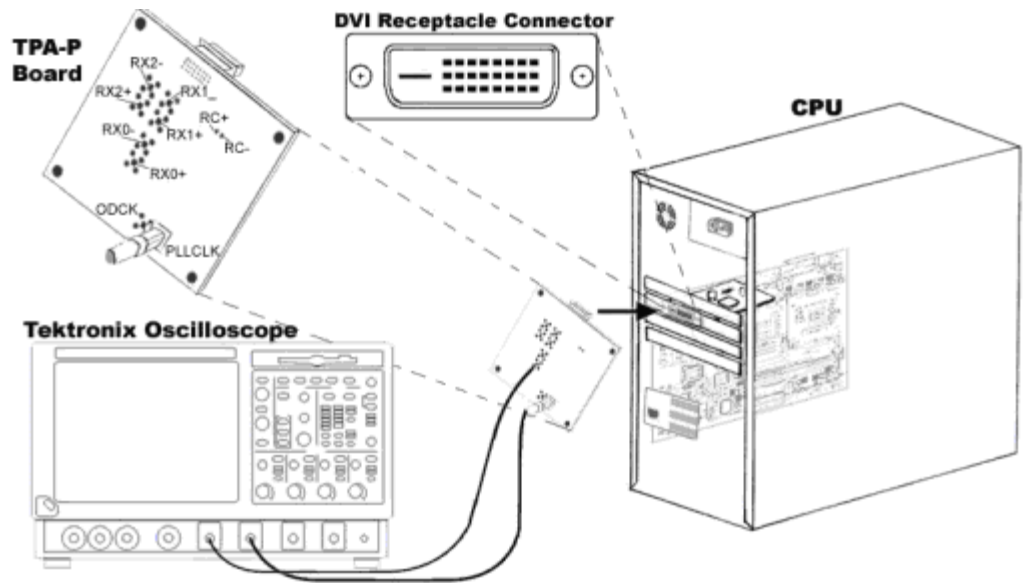

Figure 4-4: DVI monitor setup

1. Connect the DVI monitor to the DVI port of the AGP ADD Card of the PC as shown in the previous figure. Set the required screen resolution and the refresh rate. Set the host computer to run with the Half Clock Pattern to conduct the test. For information on how to set the host computer to run with a Half Clock Pattern to conduct the test, see page 182.
2. Remove the DVI monitor and attach the TPA-P fixture to the DVI port of the DUT.



Connecting the TPA-P board to the DVI transmitter

Figure 4-5: TPA-P fixture to the transmitter setup

3. Using the application, define Tbit before selecting a measurement.
4. Connect a P7350, P7330 or P6330 probe from any one of the four channels of the oscilloscope to one of the data pairs (Rx0+/-, Rx1+/-, Rx2+/-) of the TPA-P fixture. The next figure displays the Rx0 test point. As specified by the DDWG specifications, perform the Transmitter Eye Diagram test in Rx1 and Rx2 test points shown in the next figure.
5. Connect the SMA cable to either one of the remaining three channels on the oscilloscope to the PLL Clock on the TPA-P fixture. The next figure shows the PLL Clock test point.

Note: You can refer the TPA-P test points for Rx1 and Rx2 data pairs on page 185.

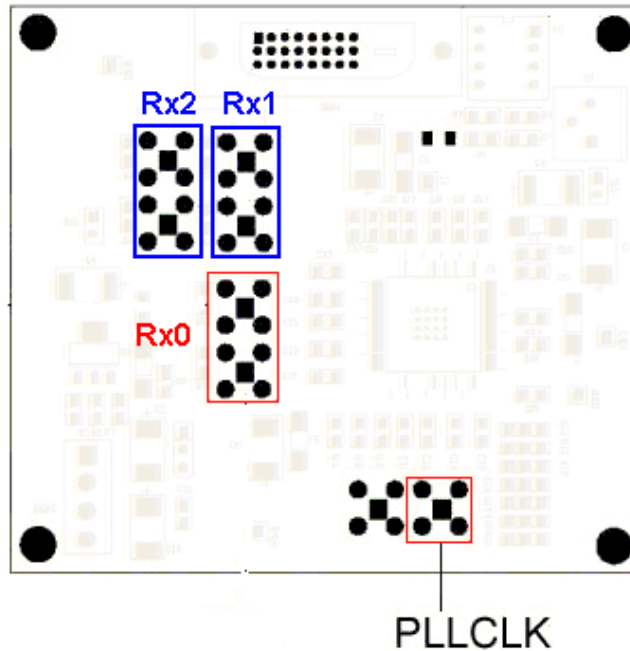

Sample test points in TPA-P for transmitter eye diagram test

Figure 4-6: TPA-P fixture test points

6. Configure the application and run the test in the application.

What do you want to do next?

Select and Configure measurements on page 70

View Results on page 74

Generate Reports on page 75

Transmitter-Rise and Fall Time

Specifying the Equipment: You need the following equipment to setup the application and test Rise and Fall Time in a Transmitter:
Transmitter Rise and Fall Time

- CSA7404, CSA7404B, TDS7404, TDS7404B, TDS7254, TDS7524B, TDS7704B, TDS6604, TDS6404, TDS6604B, TDS6804B oscilloscope with firmware version 2.2.0 or higher
- P7350, P7330, P6330 (needs TCA-BNC adapter) differential probes
- SMA cable

- TPA-P test fixture
- Device Under Test

Equipment Setup:
Transmitter- Rise and Fall
Time

To setup a **Transmitter** to measure **Rise Time/Fall Time**, follow these steps:

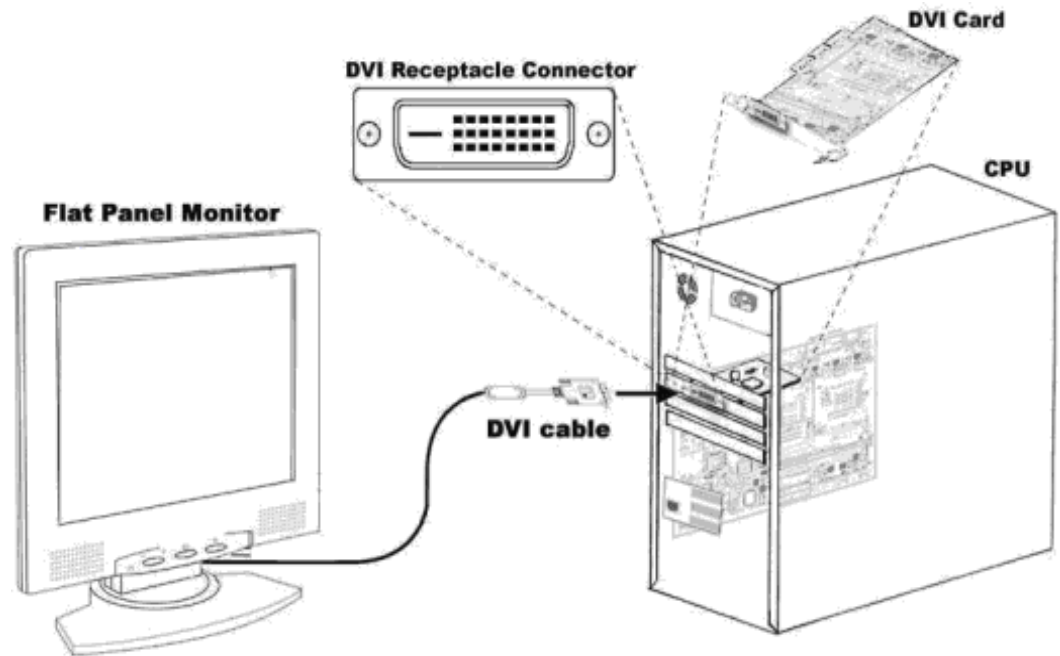
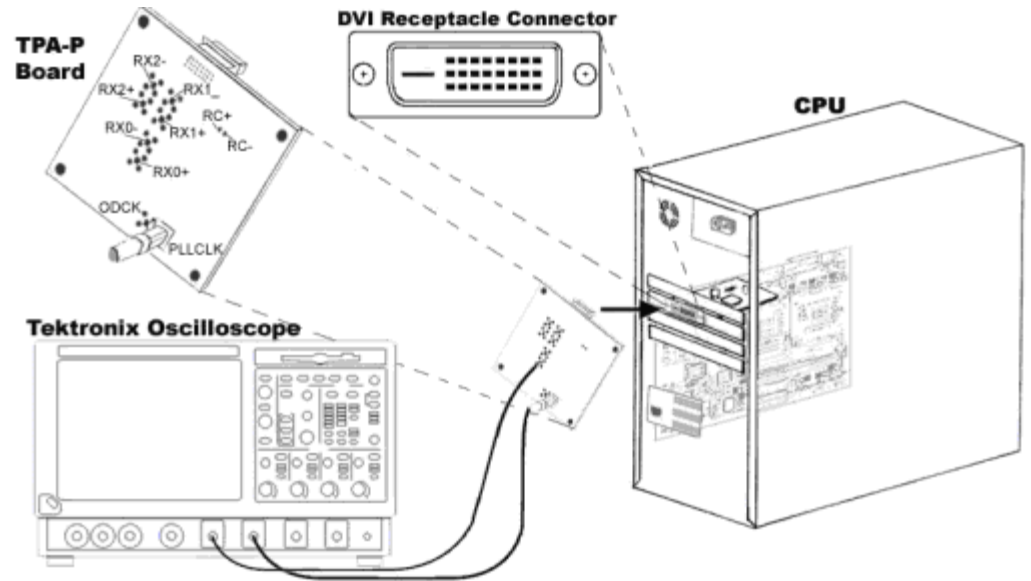

Figure 4-7: DVI monitor setup

1. Connect the DVI monitor to the DVI port of the AGP ADD Card in the PC as shown in the previous figure. Set the host computer to run with the Half Clock Pattern to conduct the test. For information on how to set the host computer to run with a Half Clock Pattern to conduct the test, see page 182.
2. Remove the DVI monitor and attach the TPA-P fixture to the DVI port of the DUT (AGP ADD card with Tx chip).



Connecting the TPA-P board to the DVI transmitter

Figure 4-8: TPA-P fixture to the transmitter setup

3. Using the application, define Tbit before selecting a measurement.
4. Connect a P7350, P7330 or P6330 probe from any one of the four channels of the oscilloscope to either of the data pairs (Rx0+/-, Rx1+/-, Rx2+/-) on the TPA-P fixture. The next figure shows the Rx0 test point. Similarly, you have to perform the tests in Rx1 and Rx2.
5. Connect the SMA cable from the remaining three channels on the oscilloscope to the SMA connector (PLL Clock) on the TPA-P fixture. The next figure shows the PLL Clock test point.

Note: You can refer the TPA-P test points for Rx1 and Rx2 data pairs on page185.

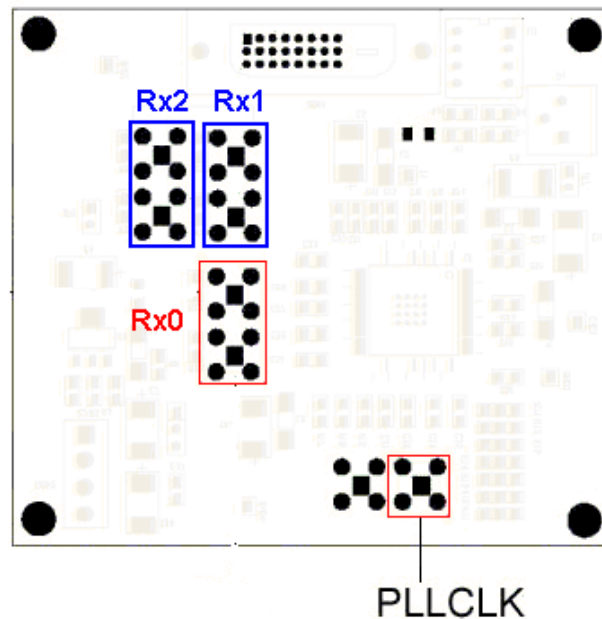

Sample test points in TPA-P for transmitter Rise and Fall time test
Figure 4-9: TPA-P test points

6. Configure the application and run the test in the application.

What do you want to do next?

Selecting and configuring measurements on page 78

Viewing Results on page 80

Generating Reports on page 75

Transmitter-Pk-Pk Jitter

Specifying the Equipment: You need the following equipment to setup the application and test Pk-Pk Jitter in a Transmitter:

Transmitter PK-Pk Jitter

- CSA7404, CSA7404B, TDS7404, TDS7404B, TDS7254, TDS7524B, TDS7704B, TDS6604, TDS6404, TDS6604B, TDS6804B oscilloscope with firmware version 2.2.0 or higher
- P7330, P7350 differential probe
- P6330 differential probe (needs TCA-BNC adapter)
- SMA cable
- TPA-P test fixture
- Device Under Test

Equipment Setup: To setup a **Transmitter** to measure **Jitter**, follow these steps:
Transmitter-Pk-Pk Jitter

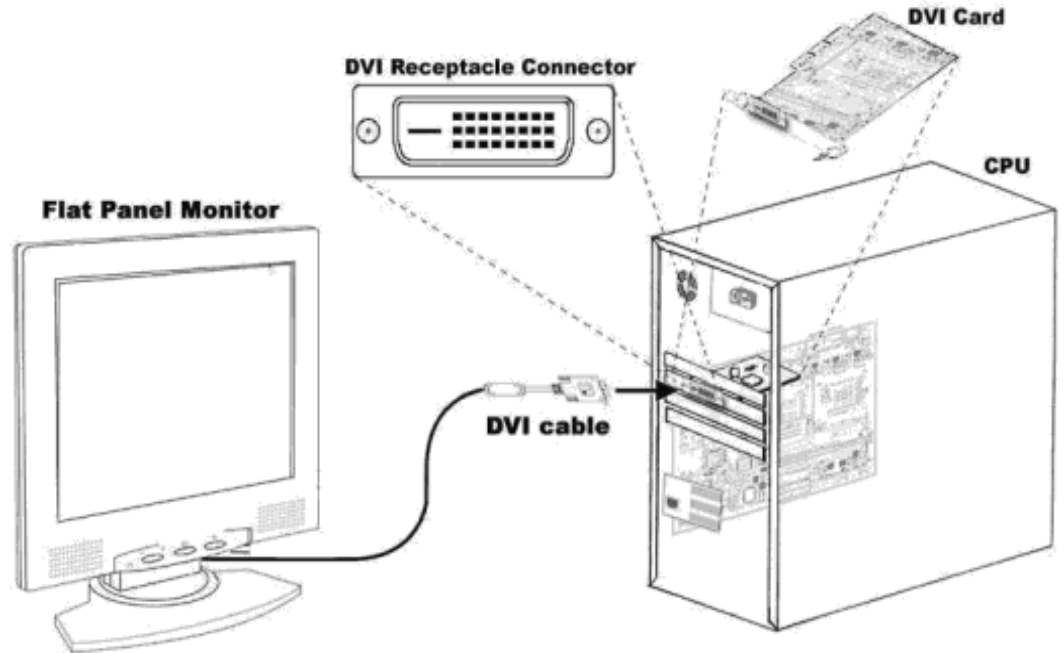
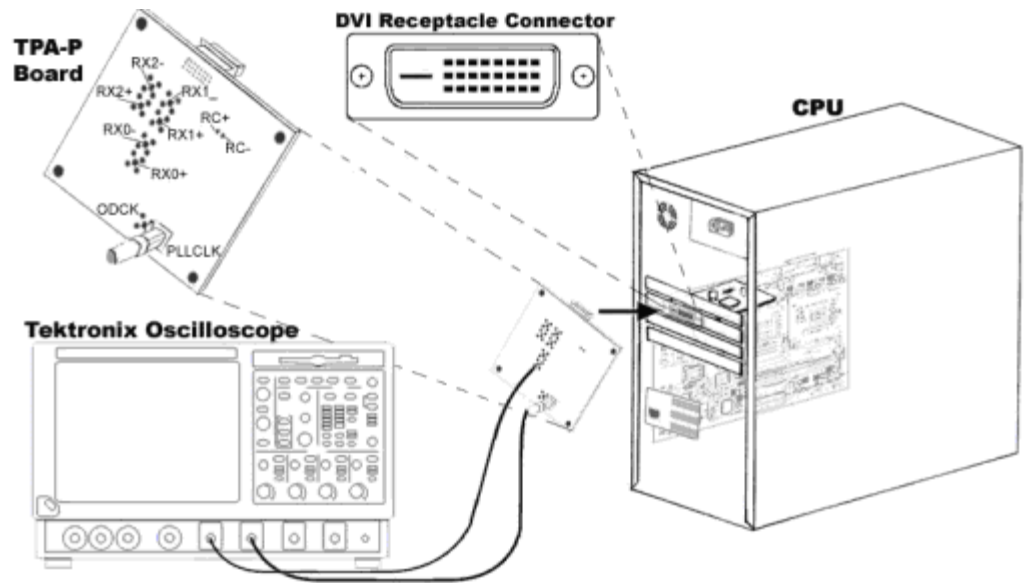

Figure 4-10: DVI monitor setup

1. Connect the DVI monitor to the DVI port of the AGP ADD Card of the PC as shown in the previous figure. Set the required screen resolution and the refresh rate. Set the host computer to run with Half Clock pattern to conduct the test. For information on how to set the host computer to run with a Half Clock Pattern to conduct the test, see page 182.
2. Remove the DVI monitor and attach the TPA-P fixture to the DVI port of the DUT.



Connecting the TPA-P board to the DVI transmitter

Figure 4-11: TPA-P fixture to the transmitter setup

3. Using the application, define Tbit before selecting a measurement.
4. Connect a P7350, P7330 or P6330 probe from any one of the four channels of the oscilloscope to the transmitted clock (Rxc+/-) on the TPA-P fixture. The next figure shows the Rxc+/- test point.
5. Connect the SMA cable from the remaining three channels on the oscilloscope to the SMA connector (PLL Clock) on the TPA-P fixture. The next figure shows the PLL Clock trigger source test point.

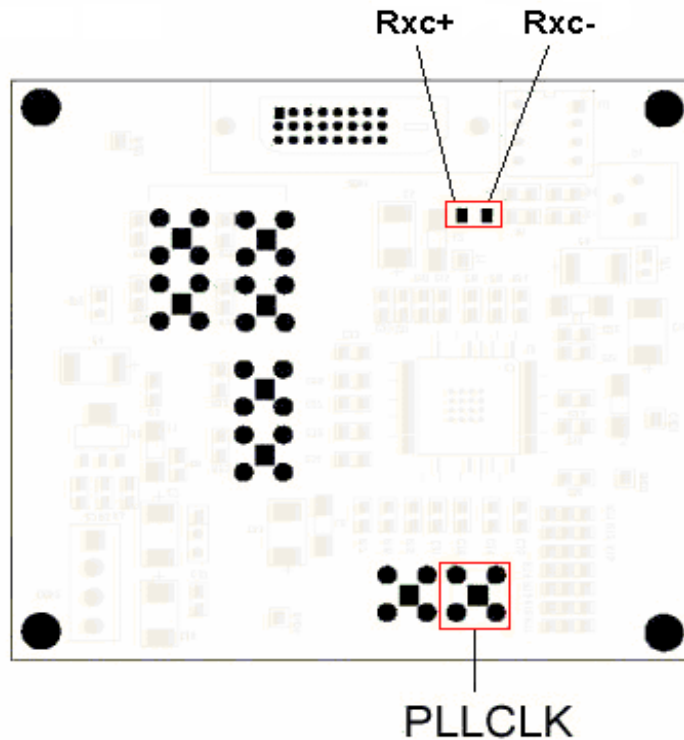

Sample test points in TPA-P for Transmitter Jitter

Figure 4-12: TPA-P test points

6. Configure the measurement and run the application.

What do you want to do next?

Selecting and configuring measurements on page 84

Viewing Results on page 87

Generating Reports on page 75

Transmitter- Intra-Pair Skew

Specifying the Equipment: You need the following equipment to setup the application and test Intra-Pair Skew in a Transmitter:

- CSA7404, CSA7404B, TDS7404, TDS7404B, TDS7254, TDS7524B, TDS7704B, TDS6604, TDS6404, TDS6604B, TDS6804B oscilloscope with firmware version 2.2.0 or higher
- P7240 or P6249 single-ended probe (two numbers)
- SMA cable
- TPA-P fixture

- Device Under Test

Equipment Setup: To setup a **Transmitter** to measure **Intra-Pair Skew**, follow these steps:
Transmitter-Intra-Pair Skew

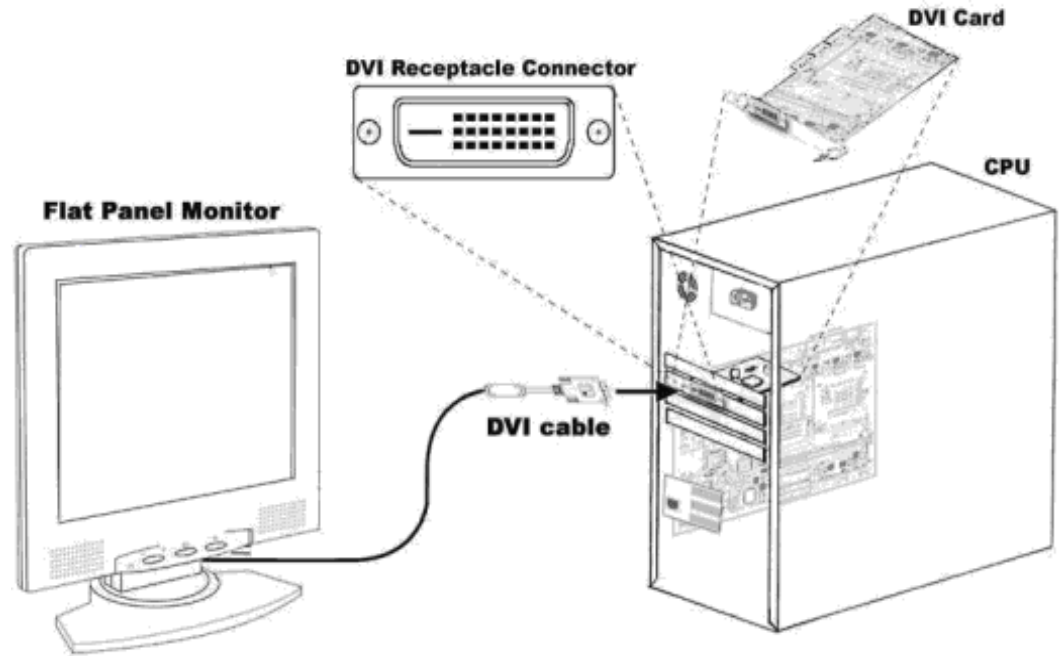
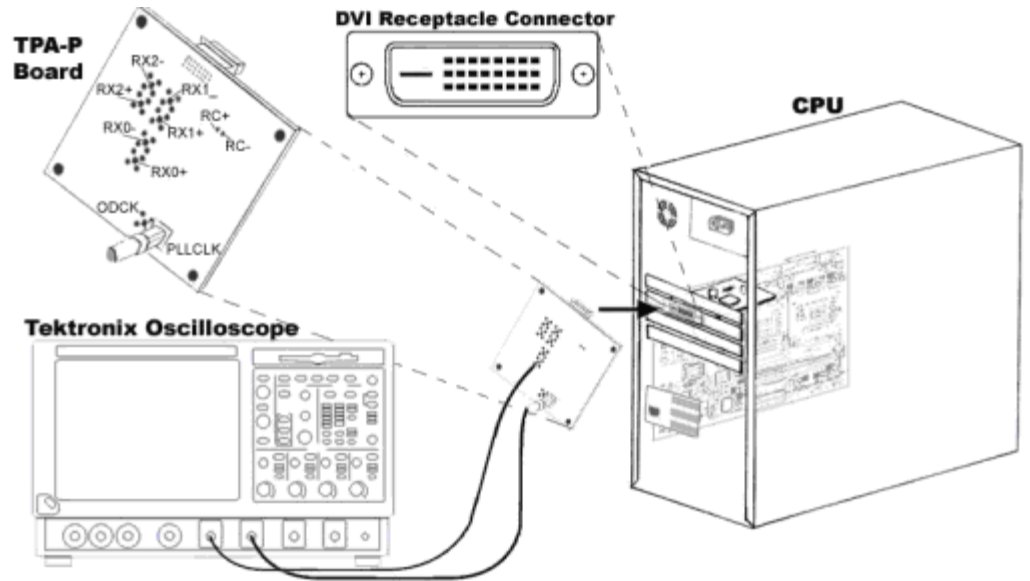

Figure 4-13: DVI monitor setup

1. Connect the DVI monitor to the DVI port of the AGP ADD Card of the PC as shown in the previous figure. Set the required screen resolution and the refresh rate. Set the host computer to run with a Half Clock Pattern to conduct the test. For information on how to set the host computer to run with a Half Clock Pattern to conduct the test, see page 182.
2. Remove the DVI monitor and attach the TPA-P fixture to the DVI port of the DUT.



Connecting the TPA-P board to the DVI transmitter
Figure 4-14: TP-AP fixture to the transmitter setup

3. Use the application to define Tbit:
 - If you have not calculated the Tbit value
 - If you have changed the device, resolution, refresh or the blanking rate after calculating the Tbit
4. Connect two single-ended probes to the Rx0+ of one data pair and Rx0- of the same data pair as shown in the next figure.

Set up for Intra-pair Skew

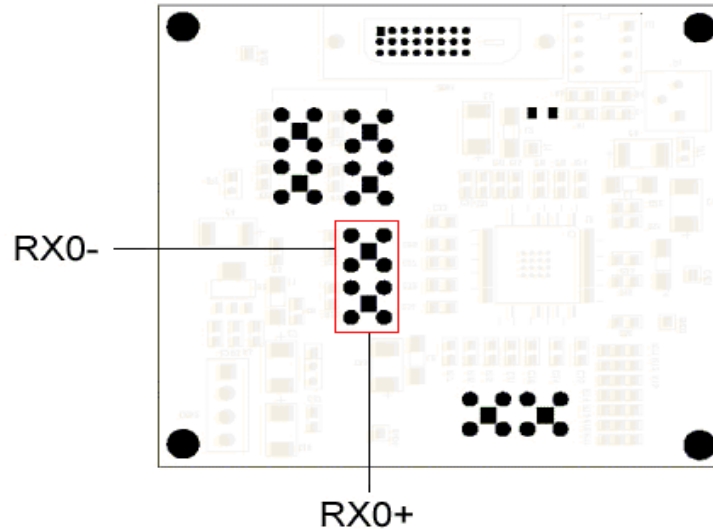

Figure 4-15: TPA-P test points

- In the application measurement configuration screen, set the **Pair** option from the drop-down menu and press **Run**.

What do you want to do next?

Select and Configure measurements on page 90

View Results on page 92

Generate Reports on page 75

Transmitter- Inter-Pair Skew

Specifying the Equipment: Transmitter-Inter-Pair Skew

You need the following equipment to setup the application and test Inter-Pair Skew in a Transmitter:

- CSA7404, CSA7404B, TDS7404, TDS7404B, TDS7254, TDS7524B, TDS7704B, TDS6604, TDS6404, TDS6604B, TDS6804B oscilloscope with firmware version 2.2.0 or higher
- P7240 or P6249 single-ended probe (two numbers)
- SMA cable

- TPA-P test fixture
- Device Under Test

Equipment Setup: To setup a **Transmitter** to measure **Inter-Pair Skew**, follow these steps:
Transmitter-Inter-Pair Skew

:

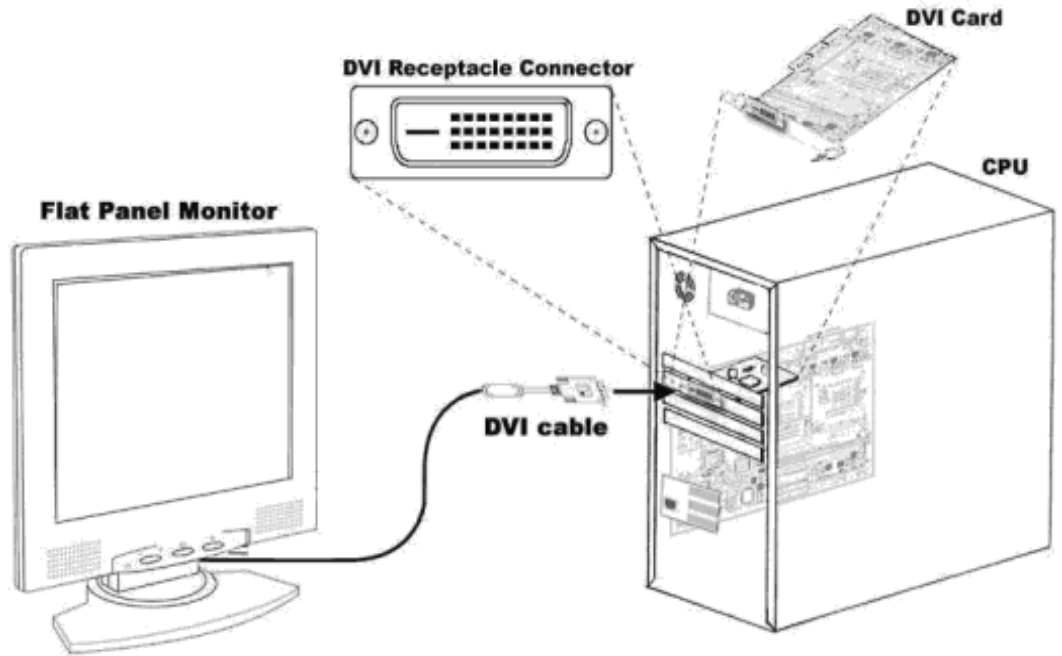
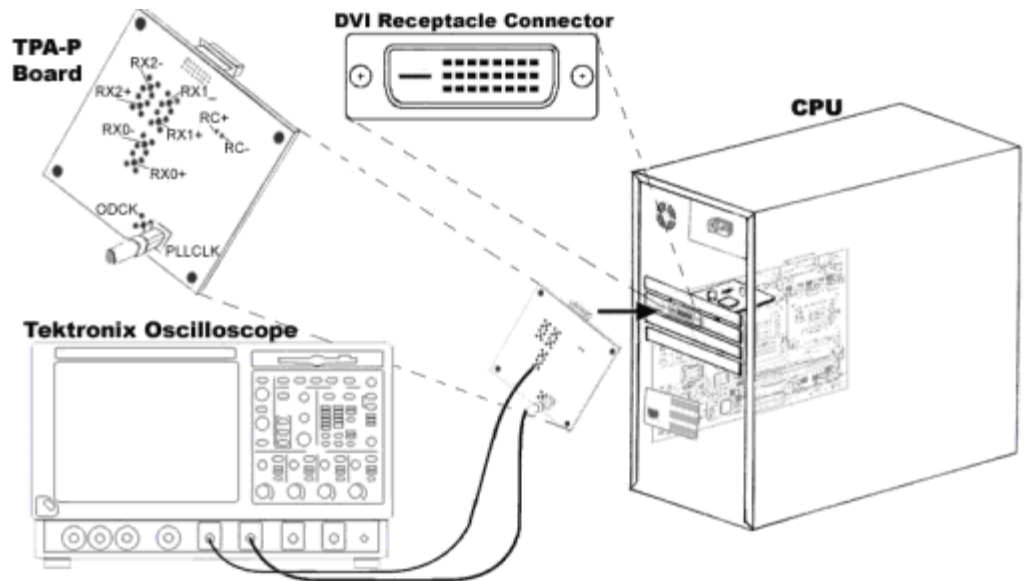

Figure 4-16: DVI monitor setup

1. Connect the DVI monitor to the DVI port of the AGP ADD Card of the PC as shown in the previous figure. Set the required screen resolution and the refresh rate. Set the host computer to run with a Half Clock Pattern to conduct the test. For information on how to set the host computer to run with a Half Clock Pattern to conduct the test, see page 182.
2. Remove the DVI monitor and attach the TPA-P fixture to the DVI port of the DUT.



Connecting the TPA-P board to the DVI transmitter

Figure 4-17: TPA-P fixture to the transmitter setup

3. Use the application to define Tbit if:
 - If you have not calculated the Tbit value
 - If you have changed the device, resolution, refresh rate or the blanking rate after calculating the Tbit
4. Connect two single-ended probes to the Rx0+ of one data pair and Rx1- of the same data pair as shown in the next figure.

Set up for Inter-pair Skew

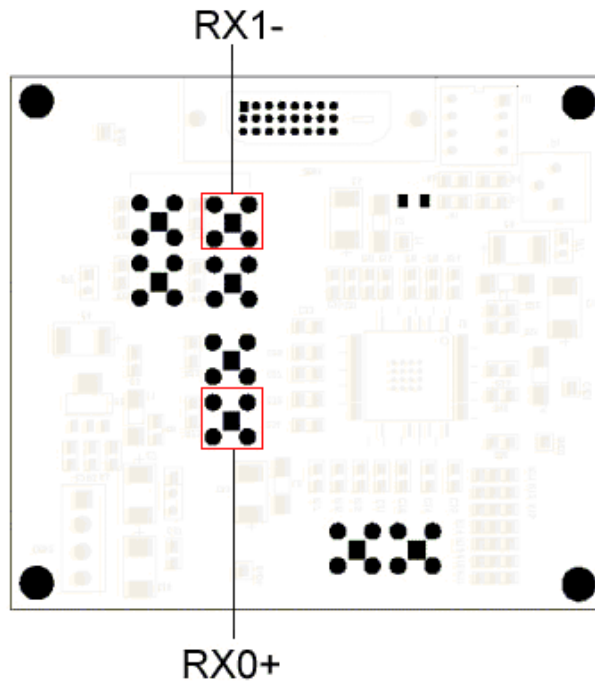

Figure 4-18: TPA-P test points

5. In the application measurement configuration screen, set the **Pair** option from the drop-down menu and press **Run**.

What do you want to do next?

Select and Configure Measurements on page 95

View Results on page 96

Generate Reports on page 75

Cable-Pk-Pk Jitter

Specifying the Equipment: You need the following equipment to setup the application and Pk-Pk Jitter in a Cable-Pk-Pk Jitter

- CSA7404, CSA7404B, TDS7404, TDS7404B, TDS7254, TDS7524B, TDS7704B, TDS6604, TDS6404, TDS6604B, TDS6804B oscilloscope with firmware version 2.2.0 or higher
- P7350, P7330, P6330 (need TCA-BNC adapter) differential probe

- SMA cable
- TPA-R test fixture
- Device Under Test

Equipment Setup: Cable Pk-Pk Jitter To setup a **Cable** to measure **Jitter**, follow these steps:

1. Connect the TPA-R board to the end of the cable as shown in the next figure.

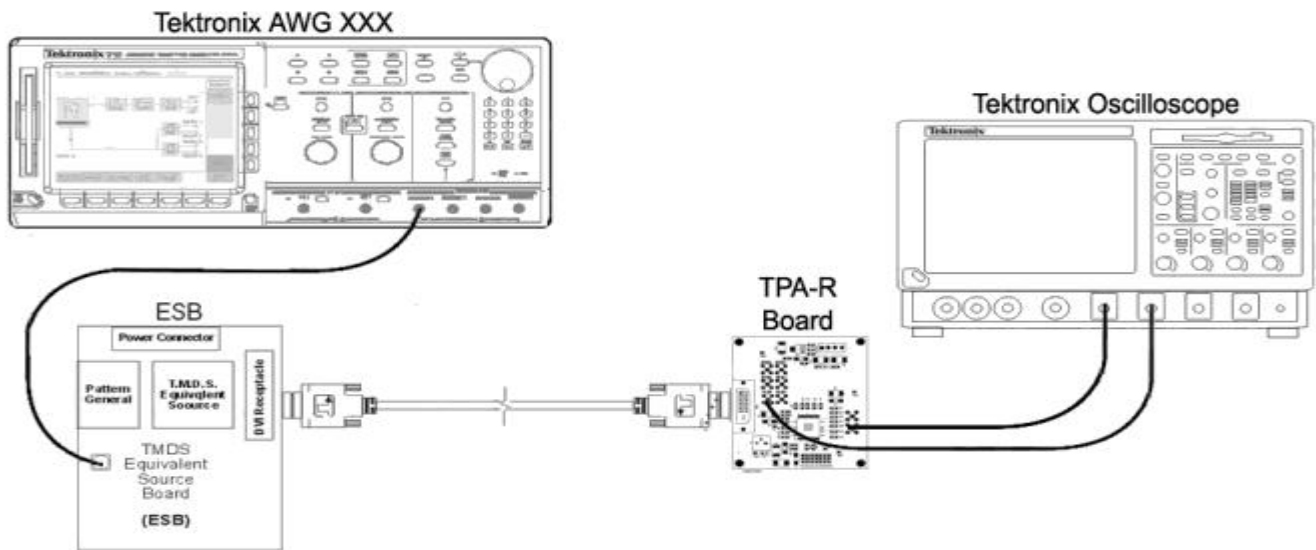

Figure 4-19: Cable Jitter setup

2. Use the application to define Tbit if:
 - If you have not calculated the Tbit value
 - If you have changed the device, resolution, refresh rate or the blanking rate after calculating the Tbit
3. Connect a P7350, P7330 or P6330 probe from any one of the four channels of the oscilloscope to the transmitted clock (Rxc+/-) on the TPA-R board. The next figure shows the RxC+/- test point.
4. Connect the SMA cable from the remaining three channels on the oscilloscope to the SMA connector (PLL Clock) on the TPA-R board.
5. Configure the measurement and run the application.

What do you want to do next?

Select and Configure measurements on page 107

View Results on page 110

Generate Reports on page 75

Cable-Intra-Pair Skew

Specifying the Equipment: Cable Intra-Pair Skew You need the following equipment to setup the application and test Intra-Pair skew in a Cable:

- CSA7404, CSA7404B, TDS7404, TDS7404B, TDS7254, TDS7524B, TDS7704B, TDS6604, TDS6404, TDS6604B, TDS6804B oscilloscope with firmware version 2.2.0 or higher
- P7240 or P6249 single-ended probes (two numbers)
- SMA cable
- TPA-R test fixture
- ESB board
- DVI-compliant cable
- Device Under Test

Equipment Setup: Cable Intra-Pair Skew To setup a **Cable** to measure **Intra-Pair Skew**, follow these steps:

1. Select and transmit the half clock pattern from the ESB board.
2. Connect the TPA-R board to the end of the cable as shown in the next figure.

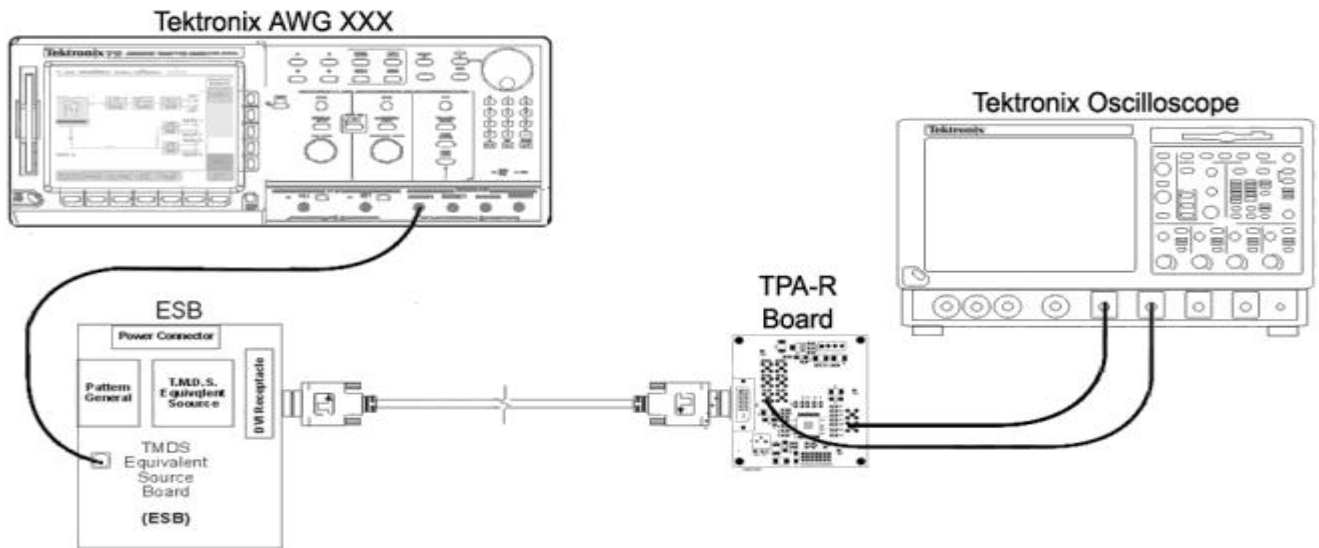
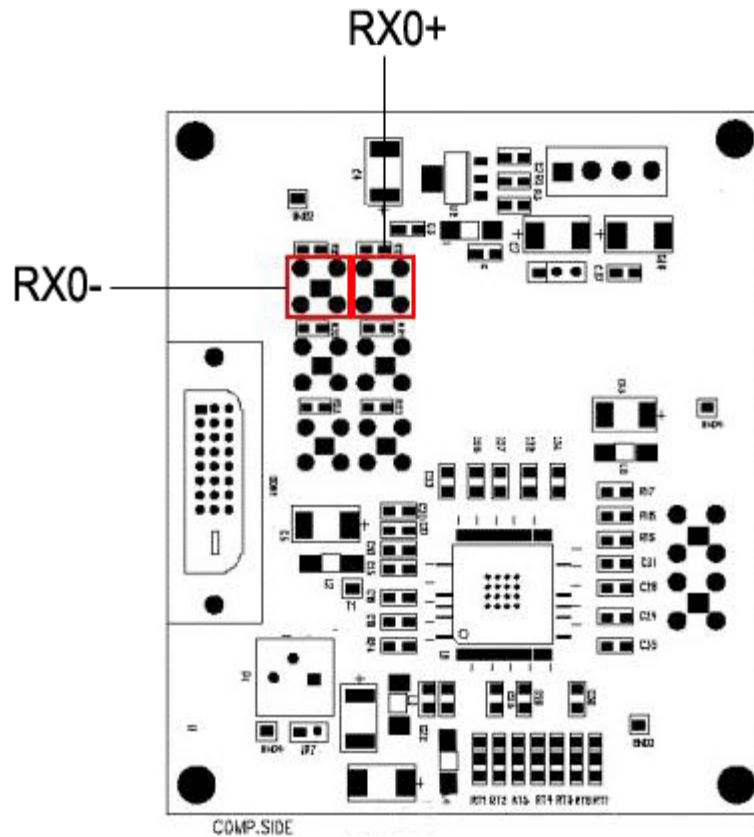

Figure 4-20: Cable Intra-Pair Skew setup

3. Use the application to define Tbit if:
 - If you have not calculated the Tbit value
 - If you have changed the device, resolution, refresh rate or the blanking rate after calculating the Tbit
4. Connect two single-ended probes in TPA-R to the Rx0+ of one data pair and Rx0- of the same data pair as shown in the next figure.



Cable Intra-Pair Skew test points

Figure 4-21: TPA-R test points

- In the application measurement configuration screen, set the **Pair** option from the drop-down menu and press **Run**.

What do you want to do next?

Select and Configure measurements on page 118

View Results on page 120

Generate Reports on page 75

Cable Inter-Pair Skew

Specifying the Equipment: You need the following equipment to setup the application and test Inter-Pair Skew in a Cable:
Cable Inter-Pair Skew

- CSA7404, CSA7404B, TDS7404, TDS7404B, TDS7254, TDS7524B, TDS7704B, TDS6604, TDS6404, TDS6604B, TDS6804B oscilloscope with firmware version 2.2.0 or higher
- P7240 or P6249 single-ended probe (two numbers)

- SMA cable
- TPA-R test fixture
- ESB board
- DVI-compliant cable

Equipment Setup: Cable Inter-Pair Skew

To setup a **Cable** to measure **Inter-Pair Skew**, follow these steps:

1. Select and transmit the half clock pattern from the ESB board.
2. Connect the TPA-R board end to the cable as shown in the next figure.

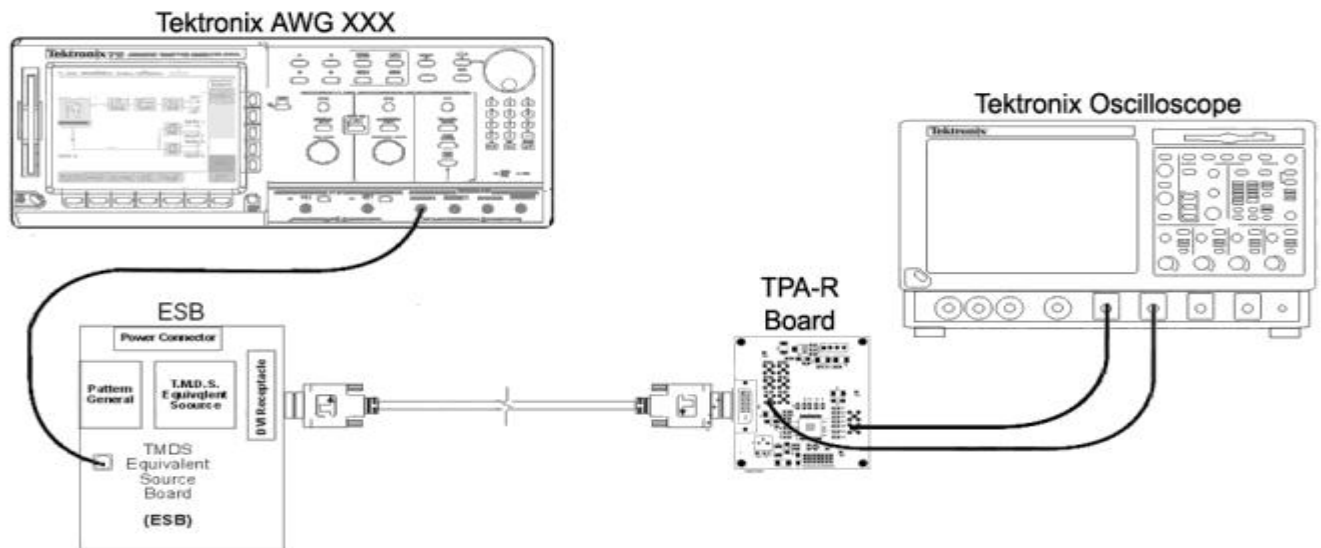
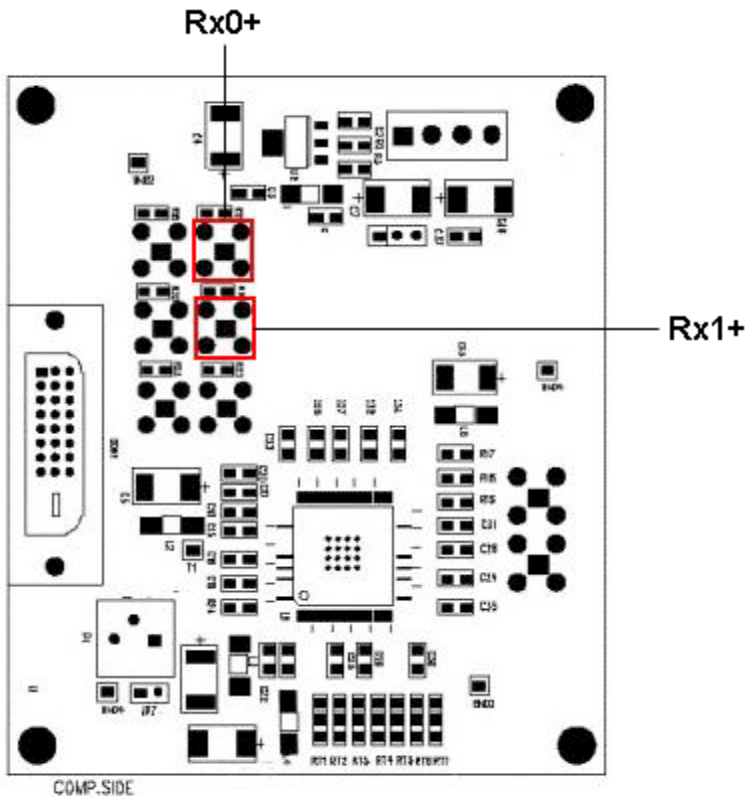

Figure 4-22: Cable Inter-Pair Skew setup

3. Use the application to define Tbit:
 - If you have not calculated the Tbit value
 - If you have changed the device, resolution, refresh and the blanking rate after calculating the Tbit
4. Connect two single-ended probes in TPA-R to the Rx0+ of one data pair and Rx1- of the same data pair as shown in the next figure. For a photographic representation of the TPA-R test points, see page 187.



Cable Inter-Pair Skew test points

Figure 4-23: TPA-R test points

5. In the application measurement configuration screen, set the **Pair** option from the drop-down menu and press **Run**.

What do you want to do next?

Select and Configure measurements on page 118

View Results on page 120

Generate Reports on page 75

Cable-Hi-Amplitude/Low-Amplitude Eye Diagram

Specifying the Equipment: You need the following equipment to setup the application and test High-Amplitude/Low-Amplitude/Low-Amplitude Eye Diagram in a Cable:

- CSA7404, CSA7404B, TDS7404, TDS7404B, TDS7254, TDS7524B, TDS7704B, TDS6604, TDS6404, TDS6604B, TDS6804B oscilloscope with firmware version 2.2.0 or higher
- P7350, P7330 or a P6330 (need TCA-BNC adapter) differential probes

- SMA cable
- TPA-P test fixture
- TPA-R test fixture
- ESB board
- DVI-compliant cable
- Device Under Test

Equipment Setup: Cable-High-Amplitude/Low-Amplitude Eye Diagram

The DVI Specifications version 1.0 specifies eye masks at TP2 (Low or High amplitude eye mask) and at TP3. The TP2 and TP3 test points are shown in the next figure.

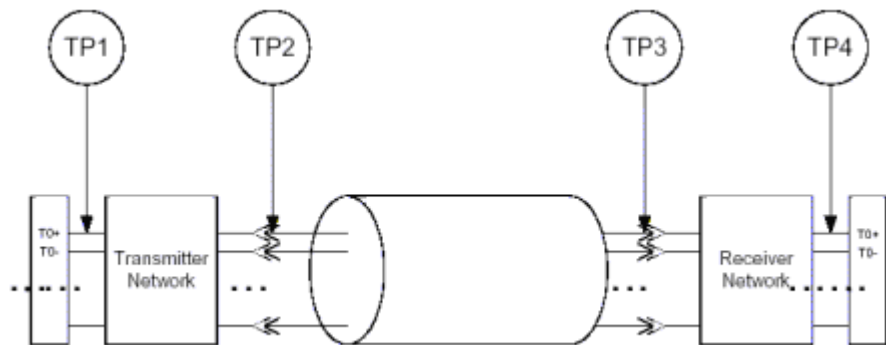

Figure 4-24: TP2 and TP3 test points

Select **File> Preferences> Advanced** tab from the application menu bar. In the Cable Eye diagram Test Point pane:

- If you select **Test at TP2 & TP3**, follow the complete procedure given below.

***Note: For expert users**—If you have a standard signal that passes low or high amplitude mask, you may not opt to test cable at TP2 with low or high amplitude mask every time you run the cable measurement. For this purpose, we recommend you to select **File> Preferences> Advanced> Cable Eye Diagram Test Point** options. If you have selected **File> Preferences> Advanced> Cable Eye Diagram Test Point> Test at TP2**, follow step 1-7 in the procedure given below. If you have selected **File> Preferences> Advanced> Cable Eye Diagram Test Point> Test at TP3**, follow step 9- 12 in the procedure given below.*

To setup a **Cable** to measure **High-Amplitude/Low-Amplitude Eye Diagram**, follow these steps:

1. Connect the TPA-P fixture to the Equivalent Source Board (ESB) as shown in the next figure.

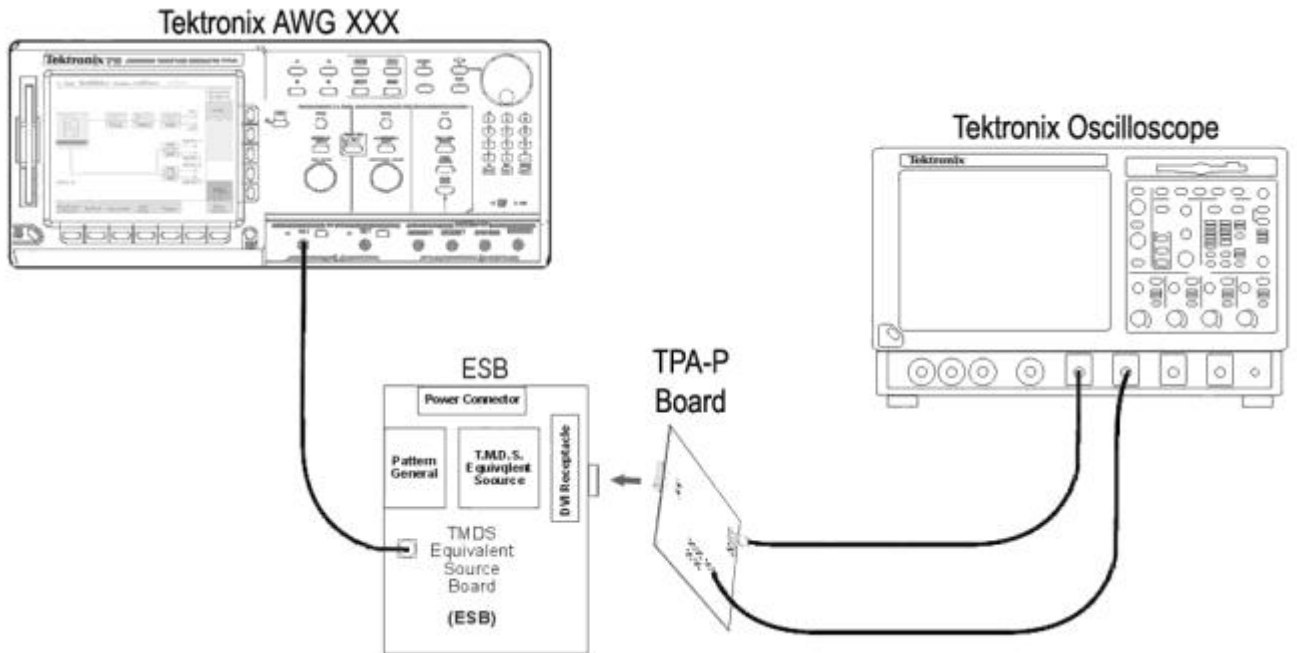
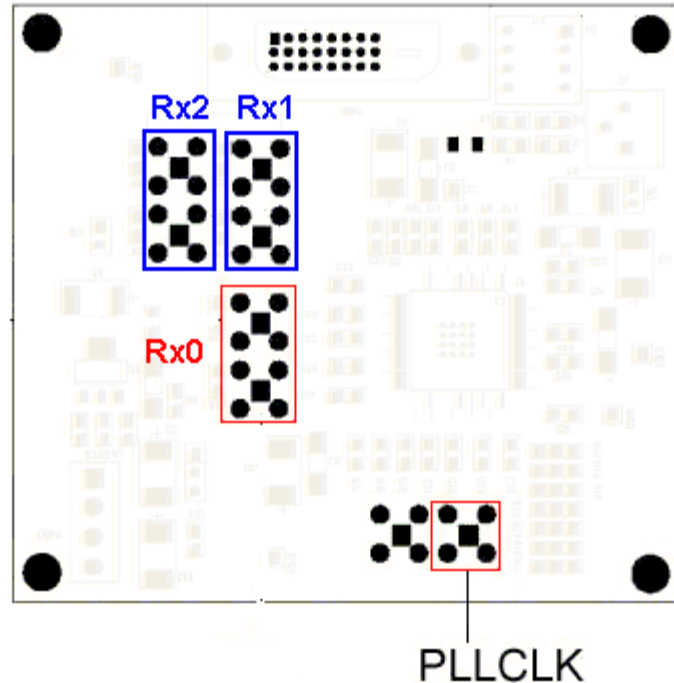

Figure 4-25: TPA-P to ESB setup

2. Use the application to define Tbit:
 - If you have not calculated the Tbit value
 - If you have changed the device, resolution, refresh rate or the blanking rate after calculating the Tbit
3. Select the **Cable> High-Amplitude/Low-Amplitude Eye Diagram** measurement.
4. Connect a P7330, P7350 or P6330 probe from any one of the four channels of the oscilloscope to one of the data pairs (Rx0+/-, Rx1+/-, Rx2+/-) of the TPA-P fixture. The next figure shows the Rx0 test point. Similarly, perform the tests in Rx1 and Rx2 test points shown in the next figure.
5. Connect the SMA cable to either one of the remaining three channels on the oscilloscope to the (PLL CLK) on the TPA-P fixture in the next figure.

Note: You can refer the TPA-P test points for Rx1 and Rx2 data pairs on page 185.



Sample test points in TPA-P for cable High/Low Amp Eye Diagram

Figure 4-26: TPA-P test points

6. Configure the application in the measurement configuration screen.
7. Press **Run** to run the Cable Low/ High Amplitude test. The application performs the test and displays the results. If the signal fails, adjust the amplitude in the ESB board and start from step one. See page 184.
8. If the signal passes the test, remove the TPA-P fixture and follow the next step.
9. Connect one end of the cable (DUT) to the ESB and the other end to the TPA-R fixture as shown in the next figure.

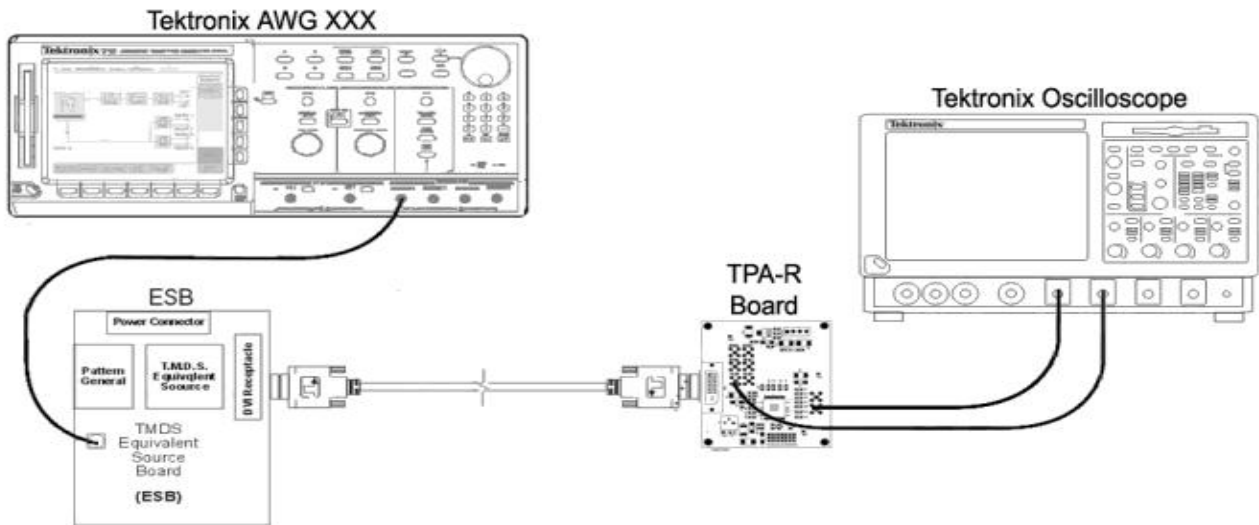
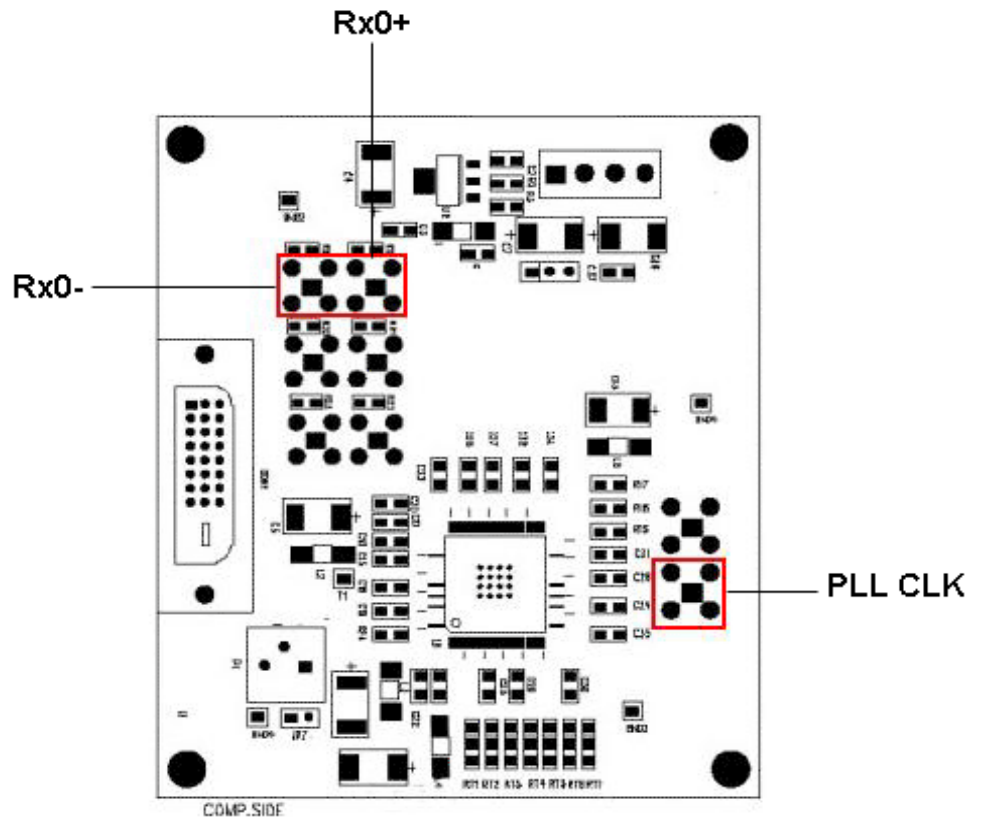

Figure 4-27: TPA-R to ESB setup

10. Connect a P7330, P7350 or P6330 probe from the selected data channel to one of the data pairs (Rx0+/-, Rx1+/-, Rx2+/-) of the TPA-R board. The next figure shows the Rx0 test point. Similarly, you can perform the tests in Rx1 and Rx2 test points shown in the next figure.
11. Connect the SMA cable from the selected trigger channel to the (PLL Clk) on the TPA-R board in the next figure. The next figure shows the TPA-R test points.



Cable High/Low Amp Eye Diagram test points

Figure 4-28: TPA-R test points

If you have selected the **TP3 test point** in **File> Preferences> Advanced** tab, configure the application and select the run button. If you have selected **Test at TP2 & TP3** option, continue measuring the cable High/ Low Amplitude Eye diagram.

What do you want to do next?

Select and Configure Measurements on page 99

View Results on page 104

Generate Reports on page 75

Receiver-Hi-Amplitude/Low-Amplitude Eye Diagram

Specifying the Equipment: You need the following equipment to setup the application and test High-Amplitude/Low-Amplitude Eye Diagram in a Receiver:

- CSA7404, CSA7404B, TDS7404, TDS7404B, TDS7254, TDS7524B, TDS7704B, TDS6604, TDS6404, TDS6604B, TDS6804B oscilloscope with firmware version 2.2.0 or higher
- P7350, P7330 or a P6330 (need TCA-BNC adapter) differential probe
- SMA cable
- TPA-R test fixture
- ESB board
- DVI-compliant cable
- Device under test

Equipment Setup Receiver: To setup a **Receiver** to measure **High-Amplitude/Low-Amplitude Eye Diagram**, follow these steps:

1. Connect the ESB, Cable and the TPA-R fixture as shown in the next figure.

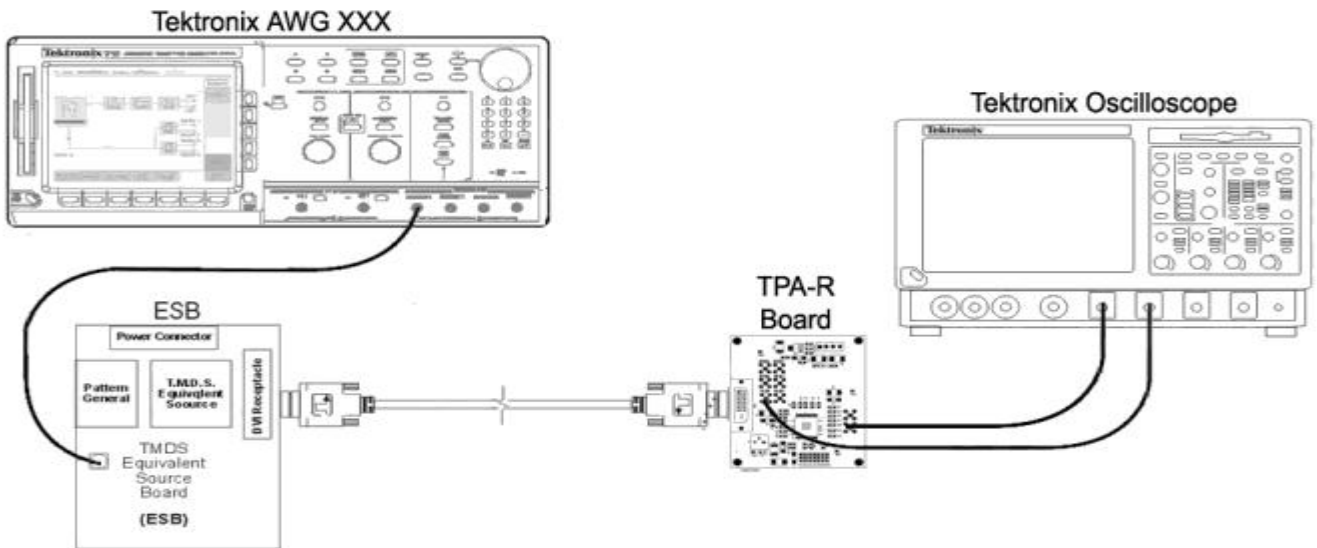
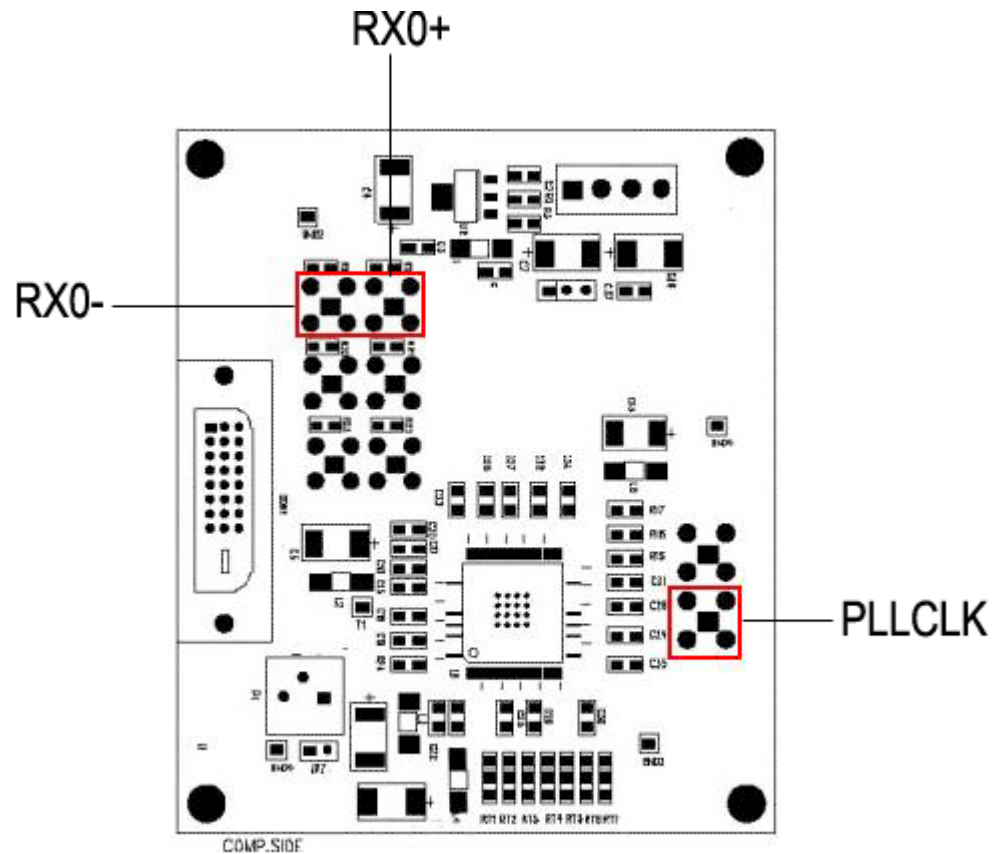

Figure 4-29: TPA-R to ESB setup

2. Use the application to define Tbit if:

- You have not calculated the Tbit value
 - You have changed the device, resolution, refresh rate or the blanking rate after calculating the Tbit
3. From the application menu, select **Receiver> High-Amplitude/Low-Amplitude Eye Diagram** measurement.
 4. Connect a P7330, P7350 or P6330 probe from any one of the four channels of the oscilloscope to one of the data pairs (Rx0+/-, Rx1+/-, Rx2+/-) of the TPA-R board. The next figure shows the Rx0 test points. Similarly, perform the tests in Rx1 and Rx2 test points shown in the next figure.
 5. Connect the SMA cable to either one of the remaining three channels of the oscilloscope to the PLL Clock of the TPA-R board as shown in the next figure.



Receiver High/Low Amp Eye Diagram test points

Figure 4-30: TPA-R test points

6. Configure the application.
7. Press **Run** to perform the measurement.
8. The application displays the message “Connect the PRP signal and press OK.” Select the PRP pattern on the ESB and press OK.

9. The application performs the Low/ High Amplitude eye mask test. If the signal passes the test, continue with the next step. If the signal has failed, increase or decrease the Vswing and run the test again until it passes. See page 184 for information on how to adjust Vswing.
10. Remove the TPA-R and connect the display device (DUT) to the receiver as shown below.

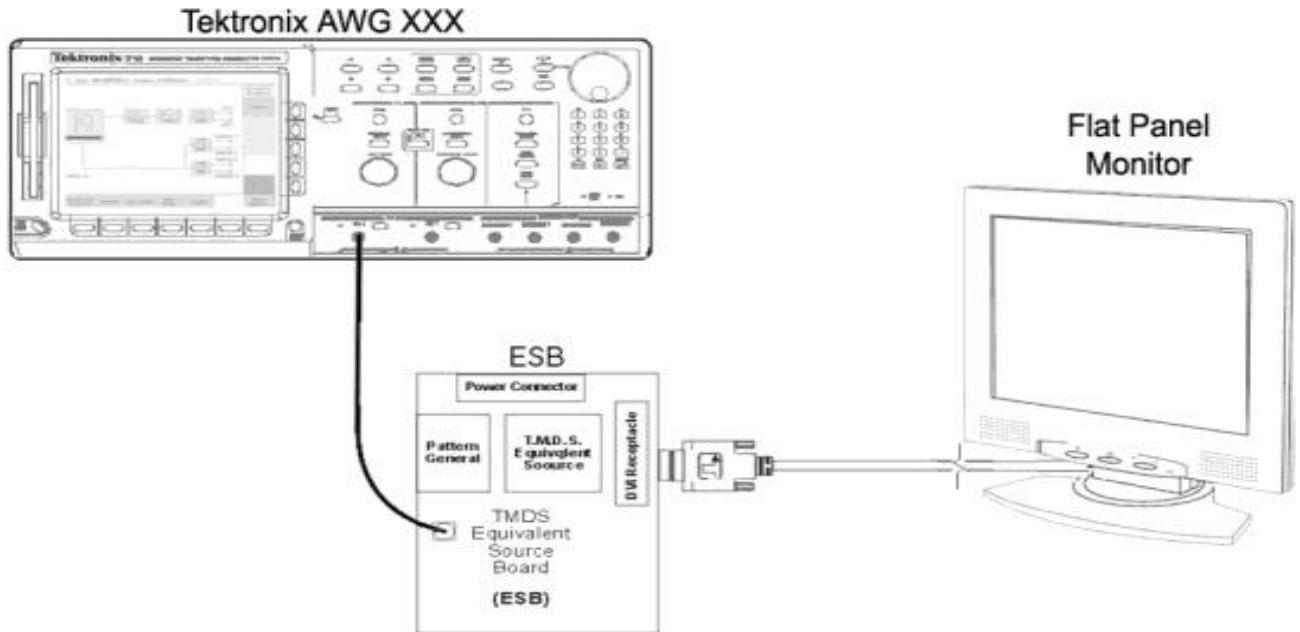

Figure 4-31: Receiver to the DUT setup

11. If the monitor displays the correct pattern on the screen, the display device passed the test.

Note: Unlike other measurements, the result status for the receiver measurement indicates that only the signal has passed and not the receiver device itself.

What do you want to do next?

Select and Configure Measurements on page 122

View Results on page 125

Generating Reports on page 75

Measurement Algorithms

Eye

The application determines the mask geometry from Tbit and Vswing using a transmitted clock signal and a differential data signal respectively. The application positions the mask at the center of the worst eye opening. The eye which has the least horizontal opening (worst eye opening) is calculated using the crossover detection algorithm. The six masks for the three types of devices are:

- Transmitter Eye mask
- Cable High Amplitude Eye mask
- Cable Low Amplitude Eye mask
- Cable TP3 Limit Eye mask
- Receiver High Amplitude Eye mask
- Receiver Low Amplitude Eye mask

Eye Openings

Vertical opening (Vopen):

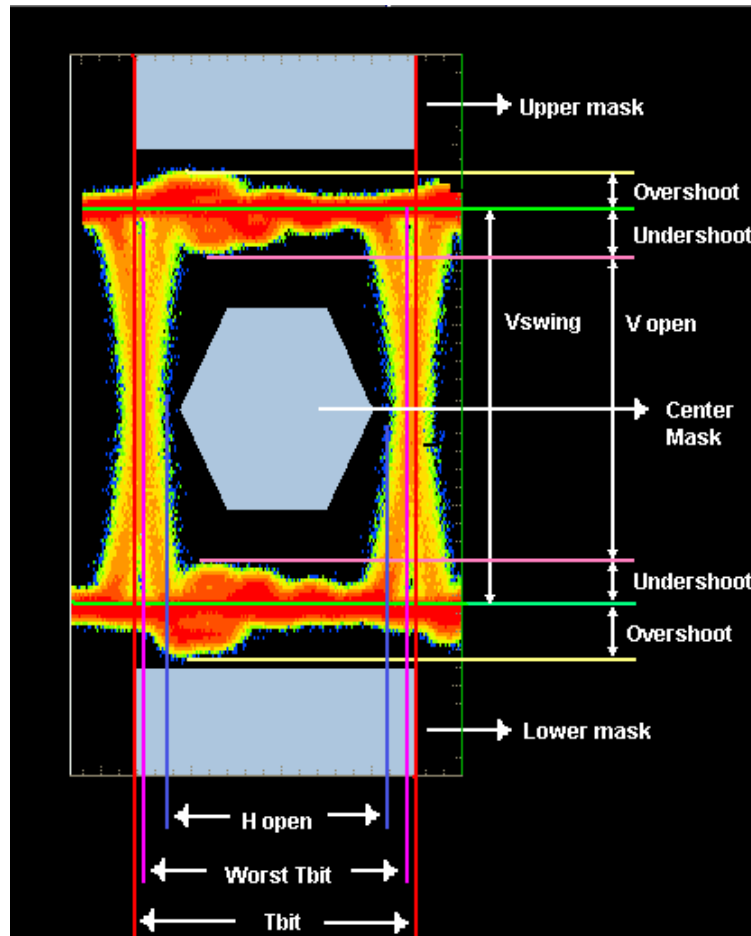

Figure 5-1:Eye definitions

The vertical eye opening is the minimum voltage difference between the high and low states after the transition. The application calculates the vertical opening at the worst eye opening and places the mask at the center of the worst eye opening. The center of the worst opening is calculated using the following equation:

$$\text{Center of worst opening eye} = (T1+T2)/2.0$$

Where:

T1 is the time at the least opening eye's left cross over

T2 is the time at the least opening eye's right cross over

Application considers the 18% before and after the center of the unit interval region as the after and before transition period and calculates the minimum voltage difference in this region. This voltage is called vertical opening.

Horizontal Opening

The minimum time difference between two crossovers of the eye diagram. This includes the effects of jitter.

Overshoot

Overshoot is voltage difference between the peak (+ve or -ve) and the normalized level (Vswing Low or Vswing High) in the previous eye diagram.

The application calculates Overshoot using the following method:

1. Find the minimum eye opening or the worst eye opening.
2. Find the positive peak and negative peak in the eye.
3. Find the normalized High (Vswing High) and Low (Vswing Low) using the histogram.
4. You can calculate:
 - $\text{Overshoot1} = \text{Positive peak} - \text{normalized high}$
 - $\text{Overshoot2} = \text{Normalized low} - \text{Negative Peak}$

The greater of Overshoot1 and Overshoot2 is used as Overshoot.

Undershoot

Undershoot is the voltage difference between the minimum high level voltage or the maximum low level voltage after the transition and the normalized voltage level (Vswing Low or Vswing High) in the eye diagram.

The application calculates Undershoot using the following method:

1. Find the minimum eye opening or the worst eye opening.
2. Find the minimum level high voltage and maximum level low voltage in the after transition region in the eye diagram.
3. Find the normalized High (Vswing High) and Low (Vswing Low) using the histogram.
4. You can calculate:
 - $\text{Undershoot1} = \text{the minimum level high voltage} - \text{normalized high}$
 - $\text{Undershoot2} = \text{maximum level low voltage} - \text{Negative Peak}$
5. The greater of Undershoot1 and Undershoot2 is used as Undershoot.

Inter-Pair Skew

Definition:

Inter-Pair Skew is the skew between the different data pairs that make up the TMDs signal. For example, the skew between Rx0+ of one pair and Rx1- is called Inter-Pair Skew. Use the single ended probe to run Inter-Pair Skew measurement.

Algorithm:

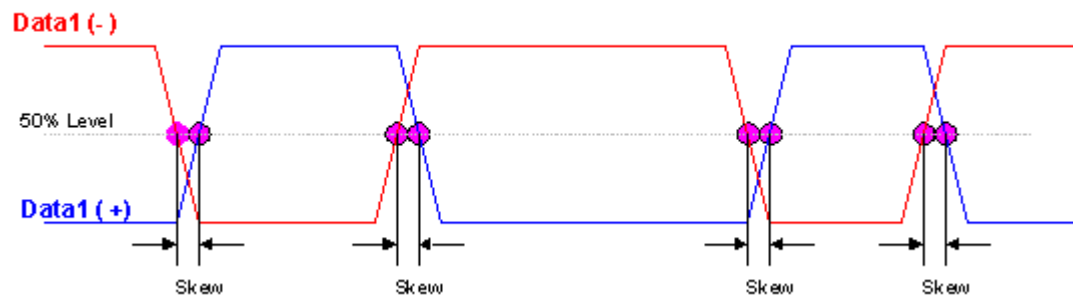

Figure 5-2: Calculation of Inter-Pair Skew

The application calculates the 50% of Pk-Pk voltage level in both signals and calculates the time difference between the two edges of the waveform.

The average of all the skew values over the acquisition period is compared with the Skew limits. The application calculates the Mean and Standard Deviation using the following equations:

If t_1, t_2, \dots, t_n are the skew values,

$$\text{Mean} = (\bar{x}) = \frac{1}{n} \sum_{i=1}^n x_i$$

$$SD = \frac{1}{n-1} \sum_{i=1}^n (x_i - \bar{n})^2$$

Where:

n= number of skews

Intra-Pair Skew

Definition:

Intra-Pair Skew is the skew between the same data pairs that make up the TMDS signal. For example, the skew between Rx0+ of one pair and Rx0- of the same data pair is called Intra-Pair Skew measurement. Use the single ended probe to run Intra-Pair Skew measurement.

Algorithm:

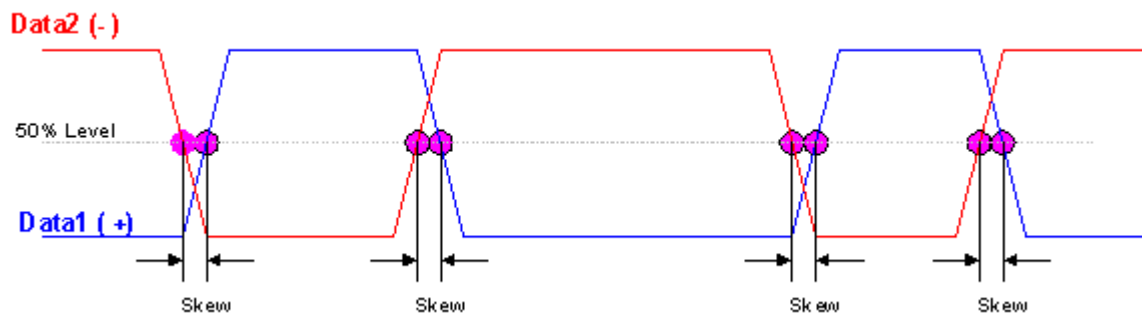

Figure 5-3: Calculation of Intra-Pair Skew

The application calculates the 50% of Pk-Pk voltage level in both signals and calculates the time difference between the two edges of the waveform.

The average of all the skew values over the acquisition period is compared with the Skew limits. The application calculates the Mean and Standard Deviation using the following equations:

If t_1, t_2, \dots, t_n are the skew values,

$$\text{Mean} = (\bar{x}) = \frac{1}{n} \sum_{i=1}^n x_i$$

$$SD = \frac{1}{n-1} \sum_{i=1}^n (x_i - \bar{x})^2$$

Where:

n= number of skews

Assumption

The application uses this algorithm with the assumption that both the data channels will transmit the same data content simultaneously.

Pk-Pk Jitter

Cable Jitter is calculated as the peak-to-peak histogram value. To calculate Pk-Pk Jitter:

1. Use the extracted clock to trigger the oscilloscope.
2. Place the histogram at the 50% level of the transmitted clock's second rising edge.
3. Measure the Pk-Pk histogram value as the Jitter value.

Rise and Fall Time

Rise Time:

Rise Time is the time interval between the 20% and 80% of normalized amplitude of the TMDS signal at Rising edge.

Fall Time:

Fall time is the time interval between the 80% and 20% of normalized amplitude of the TMDS signal at falling edge.

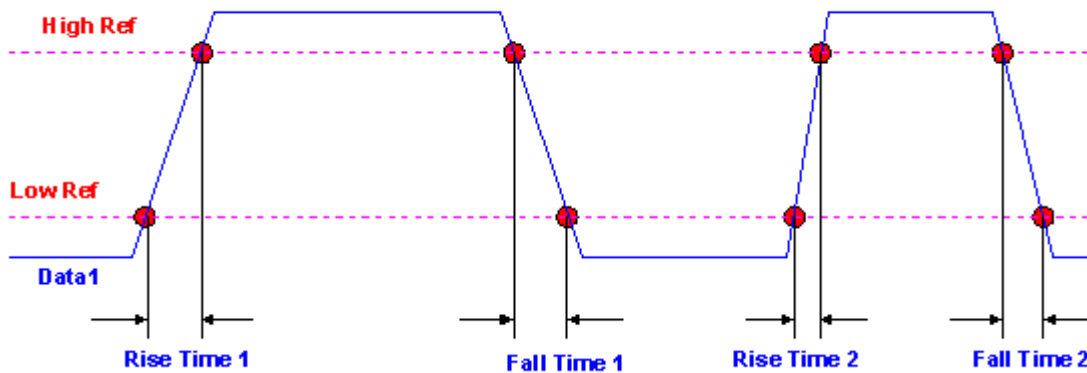

Figure 5-4: Calculation of Rise and Fall Time

In Figure 5-4:

$$\text{Low Ref} = \text{Normalized Voltage Low} + 0.2 * V_{\text{swing}}$$

High Ref = Normalized Voltage Low + 0.8 *Vswing

Vswing = Normalized Voltage High - Normalized Voltage Low calculated using Eye diagram.

Each edge is defined by the slope, voltage reference level (threshold) and Hysteresis.

The application calculates this measurement using the following equation:

Rime Time = T HighRef – T LowRef (at Rising Edge)

Fall Time = T LowRef - ThighRef (at Falling Edge)

Application calculates all the rise times and fall times in the acquisition and find Min, Max, Mean, SD.

The mean value is compared with the limit value.

Assumption

For user Vswing value, the application needs a differential signal. The Absolute value of Vswing Low and Vswing high should be the same.

Generation of Cable High Amplitude Eye Mask

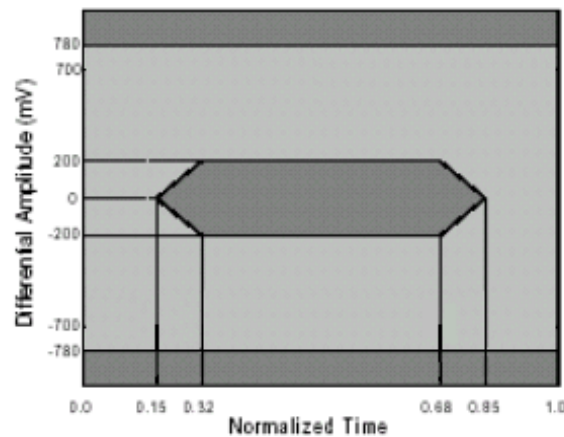

Figure 5-5: Cable High-Amplitude Eye mask

The application calculates the eye mask coordinates as a percentage of Tbit value with fixed voltage level as shown in the previous figure.

Generation of Cable Limit Eye Mask

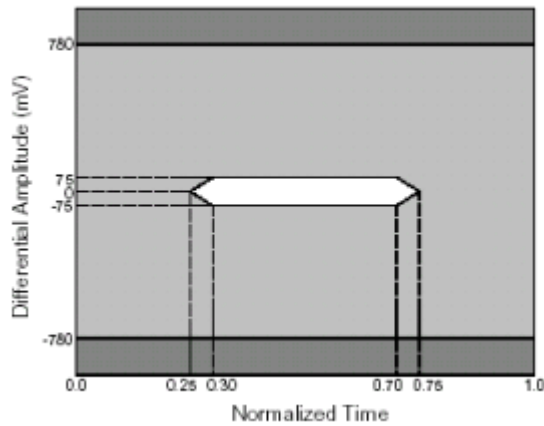

Figure 5-6: Cable Limit Eye mask

The application calculates the eye mask coordinates as a percentage of Tbit value with fixed voltage level as shown in the previous figure.

Generation of Cable Low Amplitude Eye Mask

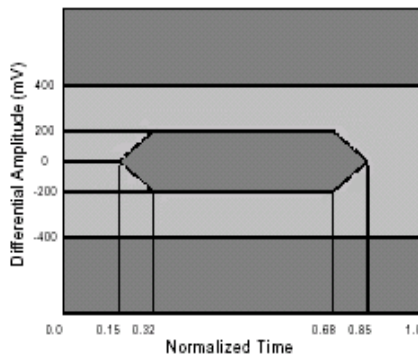

Figure 5-7: Cable Low-Amplitude Eye mask

The application calculates the eye mask coordinates as a percentage of Tbit value with fixed voltage level as shown in the previous figure.

Generation of Receiver High Amplitude Eye Mask

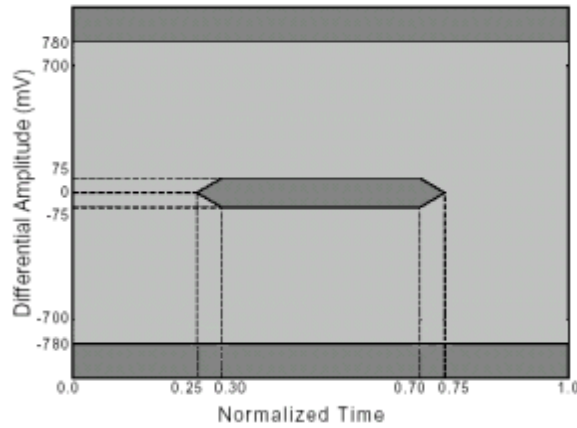

Figure 5-8: Receiver High-Amplitude Eye mask

The application calculates the eye mask coordinates as a percentage of Tbit value with fixed voltage level as shown in the previous figure.

Generation of Receiver Low Amplitude Eye Mask

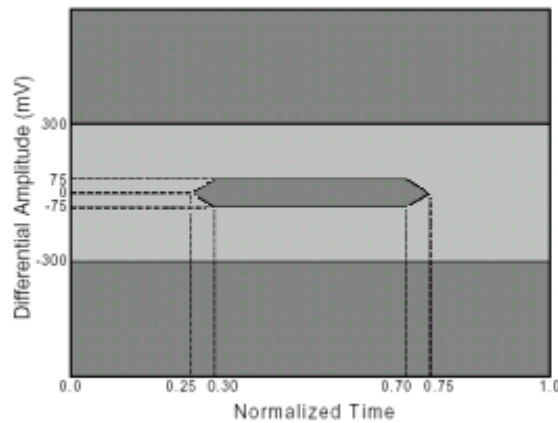

Figure 5-9: Receiver Low-Amplitude Eye mask

The application calculates the eye mask coordinates as a percentage of Tbit value with fixed voltage level as shown in the previous figure.

Generation of Transmitter Eye Mask

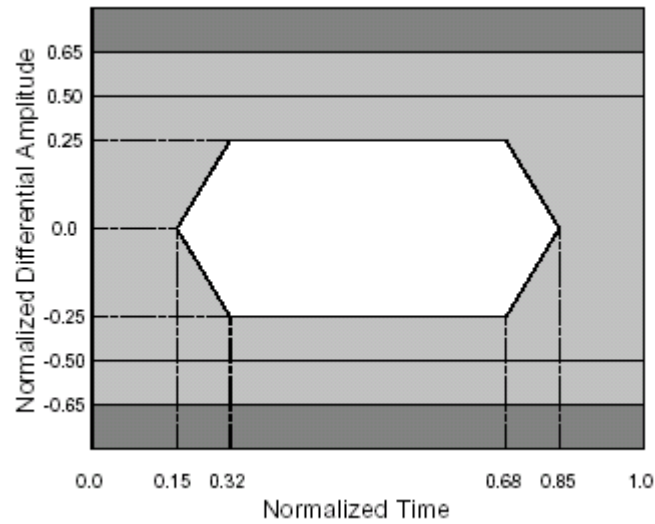

Figure 5-10: Transmitter Eye mask

The application calculates the eye mask coordinates as a normalized Tbit value with fixed voltage level as shown in the previous figure.

Reference

Equivalent Source Board

Use the ESB to test the cable assembly and receiver devices. The board has a:

- Test pattern generator (HCP or PRP)
- TMDS transmitter
- DVI receptacle to connect the cable assembly or receiver under test.

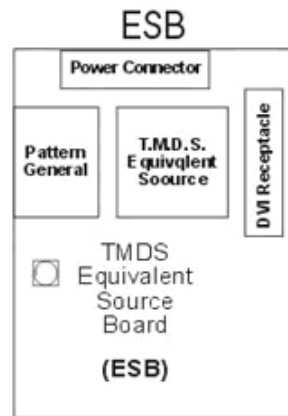

Figure 6-1: ESB board

ESB has a test pattern generator and a LCD module for a user interface to set the test modes (pattern choices and durations). To perform a test, select the appropriate resolution and pattern to be transmitted. ESB generates the required TMDS pattern along with the required DVI control signals for the Receiver test. You can also use the ESB to adjust the amplitude of a generated DVI signal.

The ESB requires a clock source to generate a pattern and introduce jitter in the TMDS clock. We recommend you to use a Tektronix AWGxxx as a clock source.

If you do not have the ESB setup shown in the Figure 6-1, you can use the following setup to create a DVI signal.

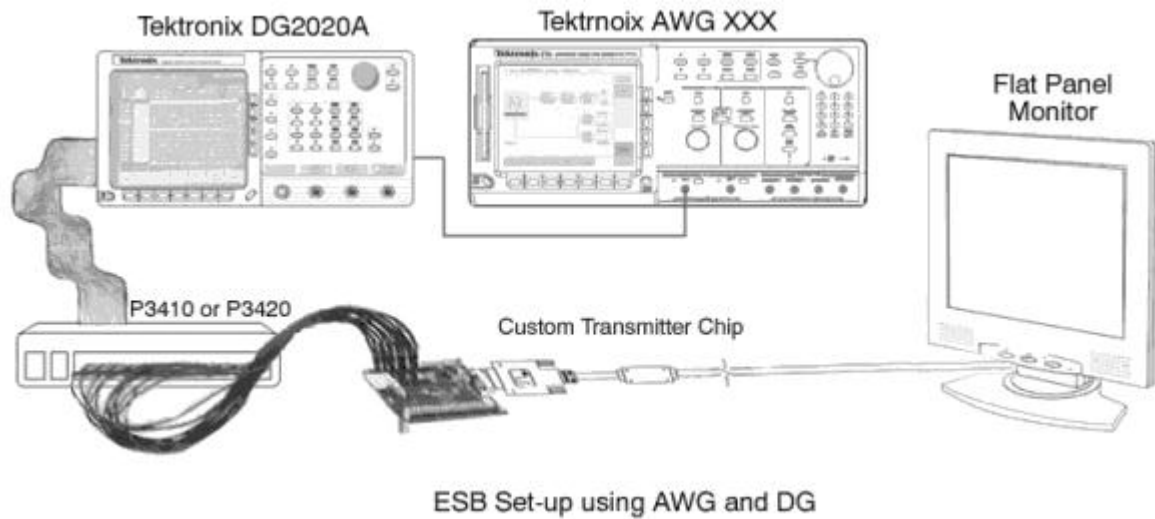

Figure 6-2: ESB board setup with AWG and DG

1. You can use the DG2020 to generate the required pattern with the DVI control signals.
2. In Figure 6-2, AWGxxx serves as a clock source for the pattern generator (DG2020A).
3. By introducing a jitter in the clock source, you can generate a jittery DVI signal for receiver testing.
4. A custom made Transmitter chip/board:
 - Converts the parallel data from the pattern generator to a DVI signal.
 - Provides an option to adjust the amplitude of the TMDS signals

Shortcut Keys

Table 6-1 lists the short cut keys to access the application.

Table 6-1: Menu options and their shortcut keys

Menu	Short Cut Keys
File	
File	Alt+ F
Recall Default	Alt F+D
Save	Alt F+V
Recall	Alt F+A
Recently Saved	Alt F+N
Recently Recalled	Alt F+Y
Preferences	AltF+E
Minimize	Alt F+Z
Exit	Alt F+X
Measurements	
Measurements	Alt+M
Select	Alt M+S
Configure	Alt M+C
Results	
Results	Alt+R
Result Detail	Alt R+l
Utilities	
Utilities	Alt+U
Report Generator	AltU+G
Compare Results	AltU+P
Help	
Help	Alt+ H
Topics	AltH+O
About TDSVDI	AltH+B
Contact Tektronix	AltH+T

Default Settings

Table 6-2 lists the default parameter settings for the application.

Table 6-2: Default parameter settings

Parameter	Selection	Default Settings
Device type tab	Transmitter, Cable Receiver	Tbit
Define Tbit>Transmitter Clock	Ch1 to Ch4	Ch1
Define Tbit> User (TDS/CSA7404/7404B, TDS7704B, TDS6604, TDS6404, TDS6604B, and TDS6804B oscilloscopes)	Min-200ps, Max-20ns	1.2ns
Define Tbit> User (TDS7254/ TDS7524B)	Min-1ns, Max-20ns	1.2ns
Transmitter> Eye, Rise Time, Fall Time		
Transmitter> Eye Diagram> Configure> Select Source	Data-Ch1 to Ch4 Trigger-Ch1 to Ch4	Ch1 Ch2
Transmitter> Eye Diagram> Configure> Select Pair	Rx0, Rx1, Rx2	Rx0
Transmitter> Eye Diagram> Configure> Eyes	Min-2, Max-10	2
Transmitter> Eye Diagram> Vswing> Pattern	Pseudo Random, Half Clock,	Pseudo Random
Transmitter> Eye Diagram> Vswing> User	Min-200mV, Max-2 Volts	400mV
Transmitter, Cable> Pk-Pk Jitter		
Pk-Pk Jitter> Source> Transmitter Clock	Ch1 to Ch4	Ch1
Pk-Pk Jitter> Source> Trigger	Ch1 to Ch4	Ch2
Transmitter, Cable> Intra-Pair Skew, Inter-Pair Skew		
Intra-Pair Skew, Inter-Pair Skew> Source1	Ch1 to Ch4	Ch1
Intra-Pair Skew, Inter-Pair Skew> Source2	Ch1 to Ch4	Ch2
Intra-Pair Skew, Inter-Pair Skew> Pair	Rx0, Rx1, Rx2	Rx0
Inter-Pair Skew> Pair1	Rx0, Rx1, Rx2	Rx0
Intra-Pair Skew, Inter-Pair Skew> Hysteresis	Min-2%, Max-10%	5%
Intra-Pair Skew> Pair2	Rx0, Rx1, Rx2	Rx1
Transmitter> Rise Time, Fall Time		
Rise Time, Fall Time> Hysteresis	Min-2%, Max-10%	5%
Receiver, Cable> High-Amplitude Eye, Low-Amplitude Eye		
High-Amplitude Eye, Low-Amplitude Eye> Select Source> Data	Ch1 to Ch4	Ch1
High-Amplitude Eye, Low-Amplitude Eye> Select Source> Trigger	Ch1 to Ch4	Ch2
High-Amplitude Eye, Low-Amplitude Eye> Select Pair> Pair	Rx0, Rx1, Rx2	Rx0
High-Amplitude Eye, Low-Amplitude Eye> Eyes	Min-2, Max-10	2
Utilities> Report Generator		
Report Setup> Clock Frequency> Resolution	For TDS/CSA 7404/7404B, TDS7704B oscilloscopes and TDS6604, TDS6404, TDS6604B, and TDS6804B oscilloscopes see page 181 For TDS7254 /TDS7524B oscilloscope see page 181	VGA

Report Setup> Clock Frequency> Refresh Rate	43, 56, 60, 70, 72, 75, 85 (These refresh rates vary and are available depending on the selected resolution)	60Hz
Preferences		
File> Preferences> User Preferences> Min number of Acquisitions	Min-500k, Max-5M (For TDS/CSA7404/7404B, TDS7704B and TDS7254/TDS7254B oscilloscopes) Min-10K, Max-1M (For TDS6604, TDS6404, TDS6604B, and TDS6804B oscilloscopes)	1M 20k

Error Codes

Table 6-3 lists the error codes for the application.

Table 6-3: Error codes, descriptions, and troubleshooting

Error Code	Display Information	Detailed Description	Probable Solution
101	There are no results to generate a report	If you try to generate a report without any results for the selected measurement, the application displays this error message.	Press the Run button and perform the measurement again.
111	Not enough acquisitions to perform measurement	The application expects to acquire a minimum number of acquisitions specified by you.	Make sure that the application configurations are proper. Check the probes and the test fixture connections.
113	Error in importing waveform from the instrument	The application could not import the waveform from the acquisition. This happens when there is no valid waveform in the acquisition memory.	Make sure that the probes and test fixture are properly connected and re-acquire the new waveform.
114	Improper waveform	Signal is not probed at the proper test points.	Follow the setup diagram and probe the proper signal for the particular measurement.
115	Failed to find the required edges on the waveform	Number of edges found on the source waveform is lesser than the minimum number of edges required to run the measurement.	a) Decrease the horizontal scale to have more complete cycles of the waveform. b) Adjust the hysteresis level of the signal to find the edge at the required level.
122	Same source cannot be selected for data and trigger source	You cannot select the same source for Data and Trigger.	Select different channel sources for Data and Trigger.
123	Same source cannot be selected for both the data pairs	You cannot select the same source for both the data pairs.	Select Different data pair sources.
124	Same source cannot be selected for Tx clock and trigger source	You cannot select the same source for Tx Clock and trigger.	Select different channel sources for Tx clock and trigger.
125	Same source cannot be selected for source1 and source2	You cannot select the same source for source1 and source2.	Select different channel sources for source1 and source2.
131	Invalid file name	The file name should not have any of the following characters: ,;,//,\,;, <, >, *, \", /, ?, @, ^, ~, \$, #, %, &, (,), +, :, ', {, }, [,], '.	Make sure to use valid characters in file names.

132	Use valid .htm or .html extensions	The file extension for the report should be .htm or .html.	Check if the extensions of the report file(s) are .htm or .html.
133	Error while generating report	The error is generated if there is no waveform plot in C:\TekApplications\TDSdvi\Reports	Press the run button and perform the measurement again.

Error Codes Cont...

Table 6-3 lists the error codes for the application.

Table 6-3: Error codes, descriptions, and troubleshooting (Cont...)

Error Code	Display Information	Detailed Description	Probable Solution
134	A valid device Id cannot contain special characters. ,://\,.,<>*,\"/,?,@,^,~,\$,#,%,&,(,),+,:;`{ } [,] , ' ,	The device Id should not have any special characters mentioned in the error display.	Check whether the Device Id contains the special characters mentioned in the error display.
135	A valid device prefix cannot contain special characters. ,://\,.,<>*,\"/,?,@,^,~,\$,#,%,&,(,),+,:;`{ } [,] , ' ,	The device prefix should not have any special characters as mentioned in error display.	Check whether the Device prefix contains the special characters as mentioned in the error display.
141	Unable to calculate Vswing. Connect the proper signal or select the cursor option from File> Preferences to obtain the Vswing value	If the signal(s) or the test fixture connections are not proper, the application is not able to calculate the Vswing.	Connect the proper signal or select the cursor option from File> Preferences menu to obtain Vswing value.
142	Unable to find the worst eye. Connect the proper signal or select the cursor option from File> Preferences to obtain worst eye opening	If the signal (s) or the test fixture connections are not proper, the application is unable to find the worst eye opening.	Connect the proper signal or select the cursor option from File> Preferences to obtain the Worst Eye value.
143	Improper Vswing or invalid signal	The application is unable to calculate the Vswing. This happens if the signal(s) or the test fixture connections are not proper or cursor is not placed at the proper position.	Connect the proper signal or place the cursor at the proper position to obtain the Vswing value.
144	The worst Tbit is greater than the calculated Tbit value	If the cursor is placed at the wrong position in the eye to find the Worst Eye or if the user Tbit value is invalid, this message appears.	Select File> Preferences> Use cursors for Eye, RT & FT testing checkbox. Place the cursor in the worst Tbit crossover points to find the worst Tbit or Use the calculate option in Define Tbit pane to calculate the Tbit value.
151	Error while deleting waveform from Ref1	The application failed to delete the Reference waveform.	Press the Run button and perform the measurement again.
161	Error in result comparison	The error is generated if there is no waveform plot in C:\TekApplications\TDSdvi\Reports (for Current Vs File option) or waveform plot not found for the selected files.	Press the run button and perform the measurement again to get the waveform plot.
162	Not a compatible result comparison	The error is generated if compared files are not compatible.	Select compatible files.
163	Not a valid path	The error is generated if the path/report given for report comparison is not valid.	Select proper report and file path for comparison or check whether the path

		The path should not have any of the following characters: ,,:,//,\\,.,<,>,*,'"/,/?,@,^,~,,\$,#,%,&,(,),+,,,`{,},[,]'	contains any special characters like ,,:,//,\\,.,<,>,*,'"/,/?,@,^,~,,\$,#,%,&,(,),+,,,`{,},[,]'
164	Same path cannot be selected for input and output files	The result comparison input file and destination path cannot be the same.	Select different path for input and output file to compare results.
165	Same path cannot be selected for both the input files	The result comparison file vs file and the two input files cannot be the same	Select different path for the two input files to compare results.
171	Please select a measurement to configure it	Tbit does not have a separate configuration panel. You have to select a measurement and configure.	The configure button can be used to configure measurements only.
172	Invalid Tbit value	If the Tbit value is not within the specified range of 200ps and 20ns in the TDS6604, TDS6404, TDS6604B, TDS6804B, TDS7404, TDS7404B, TDS7704B oscilloscopes and CSA7404, CSA7404B and between 1ns and 20ns in TDS7254 and TDS7254B oscilloscopes, the application displays this error message.	Make sure you have selected the proper Tx Clock channel for Tbit measurement or Check the test fixture connections or Change the resolution and/or the refresh rate and re-calculate Tbit.
173	Tbit calculation failed	The Tbit measurement has failed. If the Tx clock selected is not proper, the Tbit calculation can fail.	Make sure that the application has selected proper Tx Clock channel for Tbit measurement or check the test fixture connections.
174	The device is not ready	If the destination location for saving zoomed eye is not valid, the application displays this error message.	Check if the specified drive and folder to save zoomed eye is valid and ready.
175	Tbit value is not defined	If you try running a measurement without defining the Tbit value, the application displays this error message.	Use the Calculated or the User option to define Tbit before running a measurement.
176	Test is not completed	If you have selected TP2 & TP3 as test point for Cable High/Low amplitude testing, and the test is completed only for the TP2 test point, the application displays this error message.	Analyze the possible reasons for the incomplete test at TP2 and run the test again.
181	Mask coordinates are out of view	The application is not able to calculate the mask coordinates. If the signal(s) or the test fixture connections are not proper or the cursor is not placed at proper position, this message appears.	Increase the number of eyes in the configuration panel and run the test again.
182	Error while saving the zoomed eye	If the destination drive does not have enough memory to save the zoomed eye, the application displays this error message.	Check if the destination drive is has enough memory to save the zoomed eye.

Standard Resolutions

Table 6-4 lists the standard DVI resolutions.

Table 6-4: Standard resolutions

Resolution	Refresh Rate	Clock/Pixel Frequency
640 x 350	85 Hz	31.500MHz
640 x 400	85 Hz	31.500 MHz
720 x 400	85 Hz	35.500 MHz
640 x 480 (VGA)	60 Hz	25.175 MHz
	72 Hz	31.500 MHz
	75 Hz	31.500 MHz
	85 Hz	36.000 MHz
800 x 600 (SVGA)	56 Hz	36.000 MHz
	60 Hz	40.000 MHz
	72 Hz	50.000 MHz
	75 Hz	49.500 MHz
	85 Hz	56.250 MHz
1024 x 768 (XGA)	43 Hz	44.900 MHz
	60 Hz	65.000 MHz
	70 Hz	75.000 MHz
	75 Hz	78.750 MHz
	85 Hz	94.500 MHz
1152 x 864	75 Hz	108.000 MHz
1280 x 960	60 Hz	108.000 MHz
	85 Hz	148.500 MHz
1280 x 1024 (SXGA)	60 Hz	108.000 MHz
	75 Hz	135.000 MHz
	85 Hz	157.500 MHz
1600 x 1200 (UXGA)	60 Hz	162.000 MHz
	65 Hz	175.500 MHz
	70 Hz	189.000 MHz
	75 Hz	202.500 MHz
	85 Hz	229.500 MHz
1792 x 1344	60 Hz	204.750 MHz
	75 Hz	261.000 MHz
1856 x 1392	60 Hz	218.250 MHz
	75 Hz	288.000 MHz
1920 x 1440	60 Hz	234.000 MHz
	75 Hz	297.000 MHz
2048x1536(QXGA)	60 Hz	198.7 MHz

Resolutions On TDS/CSA7404/7404B, TDS7704B and TDS6604, TDS6404, TDS6604B, and TDS6804B Oscilloscopes

Table 6-5 lists the DVI resolutions on On TDS/CSA7404/7404B, TDS7704B and TDS6604, TDS6404, TDS6604B, and TDS6804B oscilloscopes.

Table 6-5: Resolutions

Resolutions
640x350
640x400
720x400
640x480(VGA)
800x600(SVGA)
1024x768(XGA)
1152x864
1280x960
1280x1024(SXGA)
1600x1200(UXGA)
1792x1344
1856x1392
2048x1536(QXGA)

Resolutions On TDS7254/TDS7254B Oscilloscopes

Table 6-6 lists the DVI resolutions on TDS7254 and TDS7254B oscilloscopes.

Table 6-6: Resolutions

Resolutions
640x350
640x400
720x400
1600x1200(UXGA)
640x480(VGA)
800x600(SVGA)
1024x768(XGA)

How do you generate Patterns (in infinite loops) to Conduct a Test?

With the host computer:

1. Copy the patterns from the oscilloscope directory C:\TekApplications\TDSdVI\Patterns to the host computer.
2. Open the specific resolution pattern with any image editor and maximize the pattern to full screen. For example, to transmit the XGA resolution PRP pattern infinitely, open the XGA resolution PRP pattern bit map in Microsoft Paint application. Select View> View Bitmap to maximize the pattern.
3. The device will transmit the selected pattern infinitely, till you exit from image editor.

With the ESB board:

Please refer the ESB specifications and user guide to generate infinite loop patterns.

Set Cursors for Eye, RT & FT Testing

The application automatically enables the oscilloscope's cursors relevant to each measurement. By default, the cursor option is not selected.

Note: Rise and Fall Time measurement uses cursors to calculate Vswing. In Eye Diagram measurement, you can use cursors to calculate Vswing and select the worst eye opening.

If you select **File> Preferences> Use cursors for Eye, RT & FT testing**,

- To calculate Vswing, the application enables the horizontal cursors in the oscilloscope and displays the following message box. Place the cursors on the Vswing high and Vswing low of the eye diagram for the Rise and Fall Time and Eye Diagram measurement. Select **Ok** to calculate Vswing.

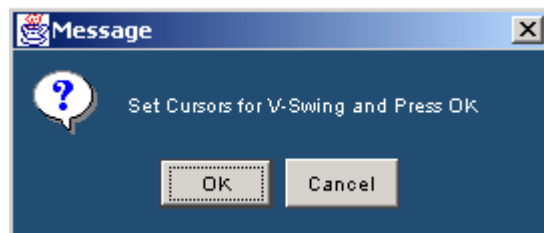

Figure 6-3: Cursors for Vswing message box

- To select the worst eye opening, the application enables the vertical cursors. Place the cursors at the crossover points of the worst eye opening for the Eye Diagram measurement. Select Ok to set the worst eye. The application places the mask on the worst eye opening.

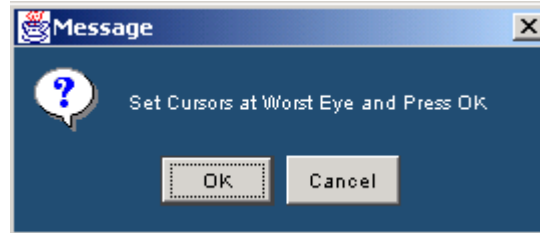

Figure 6-4: Cursors at worst eye message box

Cable Setup at TP2

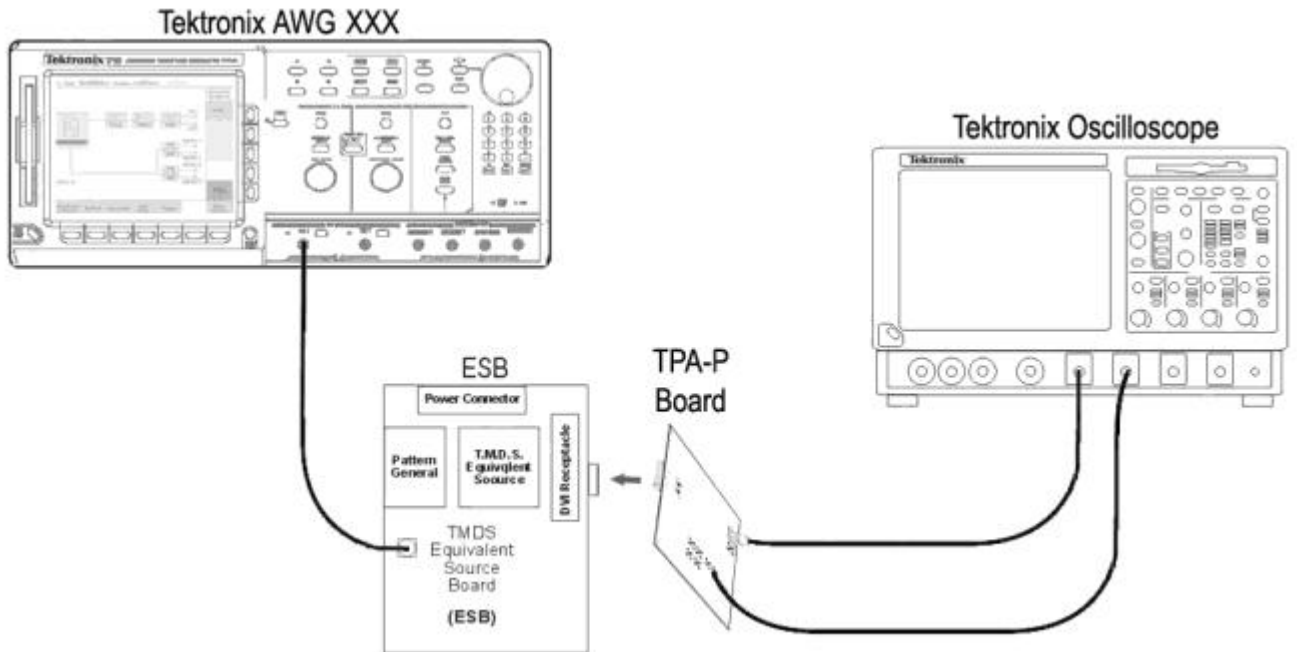

Figure 6-5: Cable setup at TP2

How do you increase or decrease the Vswing?

If signal violates the mask at TP2, the test fails and you cannot proceed further for TP3 testing, use the following guidelines given below to pass the signal:

- If the ESB generated TMDS signal violates the upper and/or the lower mask segments, decrease the Vswing value in the ESB. Refer the ESB specifications and user guide for information on how to adjust the Vswing.
- If the ESB generated TMDS signal violates the middle mask, increase the Vswing value in the ESB.
- If the ESB generated TMDS signal violates the horizontal opening in the eye mask, adjust the clock jitter.

Cable Setup at TP3

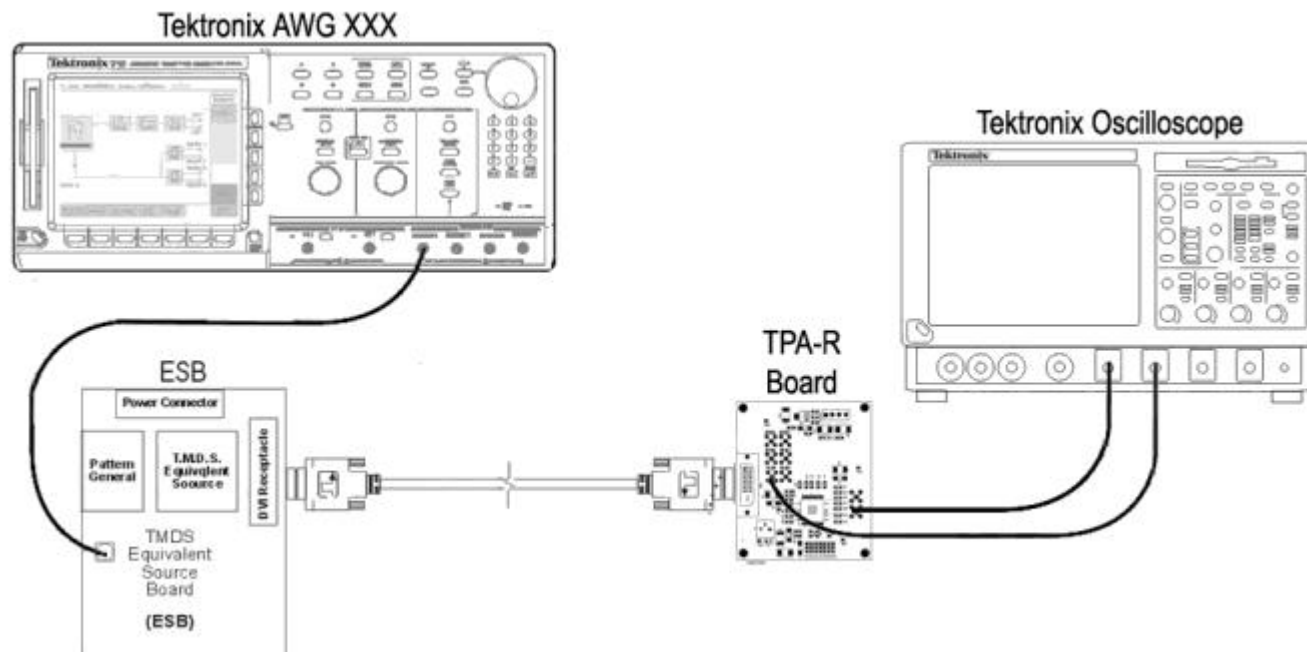

Figure 6-6: Cable setup at TP3

TPA-P Test Points

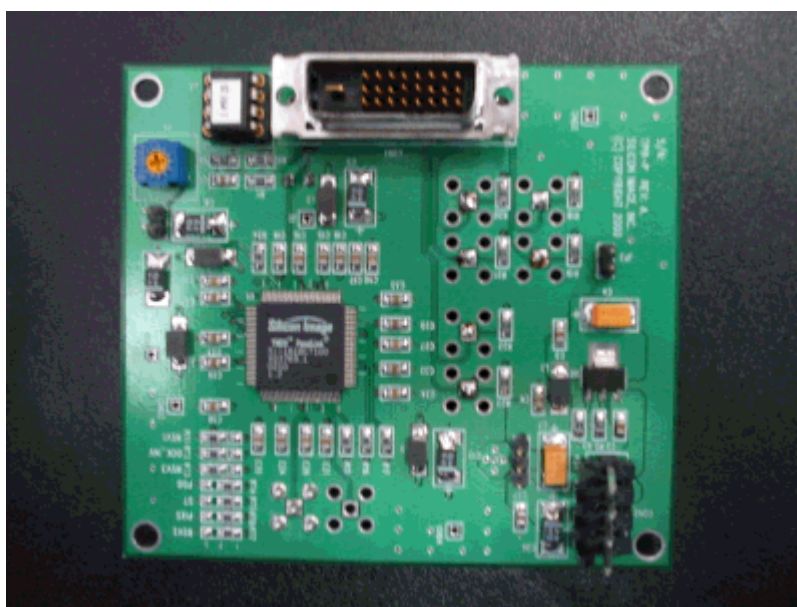

Figure 6-7: TPA-P fixture

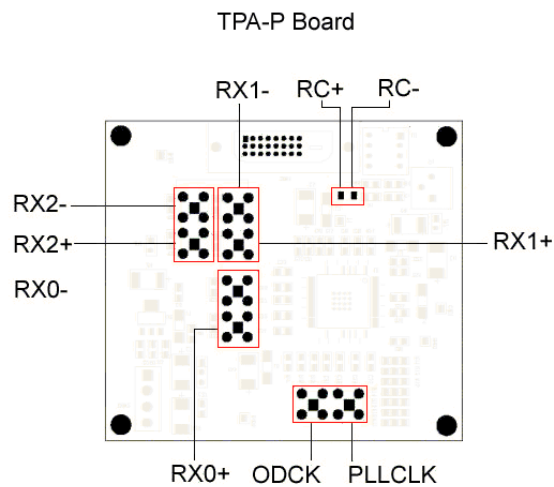

Figure 6-8: TPA-P test points

Figure 6-9 shows the component side view of the TPA-P fixture and the numbered list describes the corresponding components and the test points.

1. DVI Input connector
2. Power connector
3. JP1 1-2 for 5V, 2-3 for 3.3 V
4. PLL Clock output connector
5. P1, adjustable output swing
6. TMDS differential pair test points
7. JP2, shorted if using DVI 5V

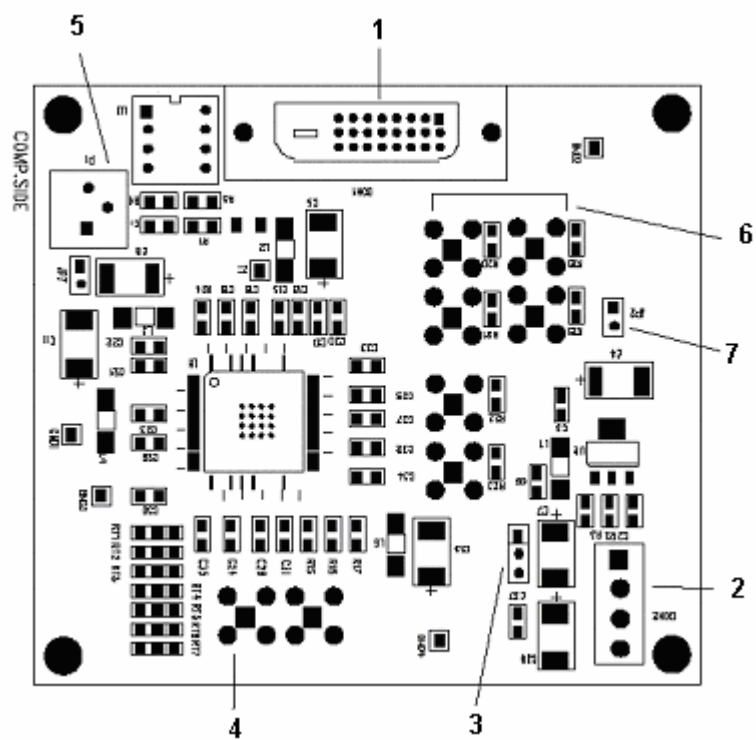

Figure 6-9: TPA-P fixture-component view

TPA-R Test Points

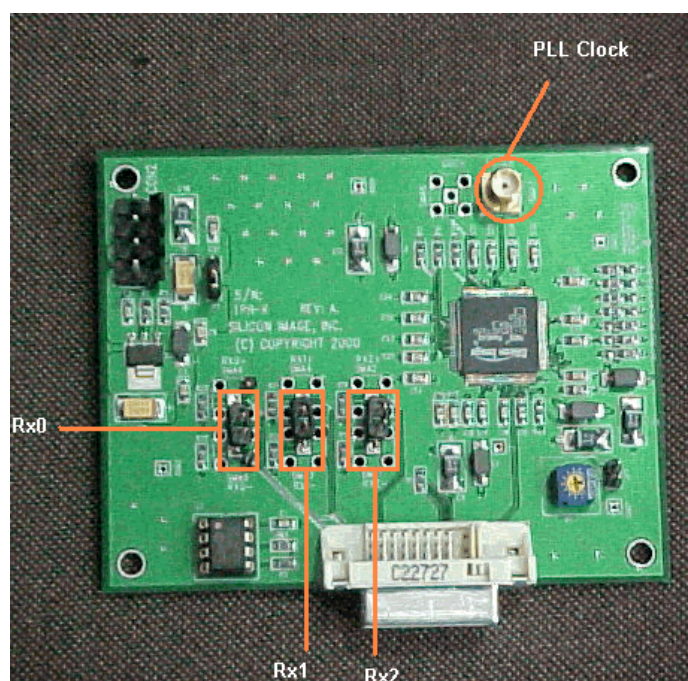

Figure 6-10: TPA-R test points

Glossary

D

DDWG: Digital Display Working Group

DVI: Digital Visual Interface

H

Hopen: The maximum horizontal opening between the closest hit points

O

Overshoot (Top and Bottom): The voltage difference between the minimum high level voltage or the maximum lowlevel voltage after the transition and the normalized voltage level ($V_{swing\ Low}$ or $V_{swing\ High}$) in the eye mask.

T

Transmitter: Is a type of device.

U

Undershoot (Top and Bottom): The voltage difference between the minimum high level voltage or the maximum low level voltage after the transition and the normalized voltage level ($V_{swing\ Low}$ or $V_{swing\ High}$) in the eye mask.

V

VESA: Video Electronics Standard Association

Vopen: The maximum vertical opening between the closest hit points.

W

Worst Tbit: The minimum distance between two consecutive crossover points

